

ALLAN HANCOCK JOINT COMMUNITY COLLEGE DISTRICT



BOARD OF TRUSTEES

Hilda Zacarias, President
Suzanne Levy, Ed.D., Vice President
Alejandra Enciso
Ken Ostini
Gregory A. Pensa
Ora Shrecengost, Student Trustee

AGENDA Board Retreat

Tuesday, July 15, 2025

Allan Hancock College
Lompoc Valley Center

Open Session – Building 3 – Room 114 – 10:00 a.m.
One Hancock Drive, Lompoc, CA 93436

	<u>Page</u>	<u>Tentative Time</u>
1. Call to Order		10:00 AM
2. Pledge of Allegiance		
3. Approval of Agenda as Presented		
4. Public Comment		
<p>Public comments on an agenda item or another topic within the jurisdiction of the board of trustees will be given in person during the meeting or submitted in writing at least 24 hours before the meeting via email to: jmcgee@hancockcollege.edu The leading speaker from the audience on each side of the issue will be limited to five minutes. Additional speakers are limited to two minutes. Please submit an individual comment for each item. Testimony on specific agenda items will be welcome during consideration of the item by the Board of Trustees. When public testimony is completed regarding a specific agenda item, discussion is then confined to board members only. This practice is in accordance with laws governing Board of Trustees public meetings.</p>		
5. Seating of Student Trustee		
<p>Administration of the oath of office and seating of Student Trustee, Daisy Garcia</p>		
6. Approval of Minutes		
6.A. Approval of Minutes from the June 10, 2025, regular board meeting	4	
7. Presentations		
7.A. Board Communication Best Practices		
<p>Dr. Sunita Cooke, president, Mira Costa College</p>		

7.B. Capital Facilities Presentation

Associate Superintendent Curran will give a presentation.

7.C. PCPA Season 62 Overview

Mark Booher, artistic director/dean, PCPA, will provide an overview of season 62 plays.

8. Consent Agenda

Consent agenda items are consistent with adopted policies and approved practices of the district and are deemed routine in nature. They will be acted upon by roll-call vote in one motion without discussion unless members of the board request an item's removal from the consent agenda.

8.A	Approval of Register of Warrants and Payroll Summary 05/01/25 through 05/31/25	11
8.B	Approval of Employee Personnel Actions	14
8.C	Approval of Appointment of Academic Management Employee	19
8.D	Approval of Part-time Faculty Appointments, Regular Faculty Overload Assignments and Special Assignments/Stipends	20
8.E	Approval of Equivalency Certification for Faculty	35
8.F	Second Review of K-12 CCAP Agreements with the School Districts	40
8.G	Approval to Award Contract for the Espresso Stand Operations (RFP #25-05)	221
8.H	Approval to Award Contract for the Campus Road and Parking Lot Slurry Seal and Restriping Project (Bid #25-06)	224
8.I	Approval of Notice of Completion for Heating, Ventilation and Air- Conditioning Updates for the District	226
8.J	Authorization for Out-of-State Travel for students	227
8.K	Second Review of Revised Board Policy 3930, Minors on Campus	228
8.L	Second Review of Revised Board Policy 5410, Associated Students Election	231
9.	Action Items	
9.A	Adoption of Resolution 25-28, Approval to Withdraw from Self-Insured Schools of California and Establish a New Self-Insurance Fund Account with the County of Santa Barbara for Self-Insurance Medical Benefits	233

	<u>Page</u>	<u>Tentative Time</u>
9.B. Acceptance of Grants Approved and Review of Grant Proposals Submitted	236	
10. Information		
10.A. Chapter 2 Board Policies	238	
10.B. Board Self-Evaluation	286	
10.C. Acceptance of Employee Retirements and Resignations	290	
10.D. First Review of K-12 CCAP Agreements with the School Districts	291	
10.E. A Monthly Report on the Year-to-Date Financial Data for Various Funds	339	
11. New Business		
12. Calendar	362	
13. Adjournment		

The next regular meeting of the Board of Trustees will be held on Tuesday, August 19, 2025, in Santa Maria. Closed session begins at 5:00 p.m. Open session begins at 6:00 p.m.



Kevin G. Walthers, Ph.D.
Secretary to the Board of Trustees

ALLAN HANCOCK JOINT COMMUNITY COLLEGE DISTRICT



BOARD OF TRUSTEES

Hilda Zacarías, President
 Suzanne Levy, Ed.D., Vice President
 Alejandra Enciso
 Ken Ostini
 Gregory A. Pensa
 Ora Shrecengost, Student Trustee

MINUTES

Regular Board Meeting
 Tuesday, June 10, 2025

Boys & Girls Club
 Closed Session – Arts and Crafts Room
 Open Session – Gym
 4689 11th Street, Guadalupe, CA 93434

1. Call to Order

Trustee Zacarías called the meeting to order at 5:22 p.m. with the following trustees present:
 Levy, Ostini, Pensa, Zacarías

Trustees absent: Enciso

Administrators present: Curran, Curry, Siwabessy

2. Public Comment to Closed Session

No public comment was made.

3. Adjourn to Closed Session

Trustee Zacarías adjourned the meeting to closed session at 5:22 p.m.

4. Reconvene to Open Session

Trustee Zacarías reconvened the meeting to open session at 6:00 p.m.

Administrators present: Bach, Curran, Curry, Hooten, Siwabessy, Specht

5. Action Taken in Closed Session

Trustee Zacarías reported there was no action taken during closed session.

6. Pledge of Allegiance

Student Trustee Shrecengost led the audience in the pledge of allegiance.

7. Approval of Agenda as Presented

On a motion by Trustee Ostini, seconded by Trustee Pensa, the board of trustees approved the agenda, on a roll-call vote as follows:

Ayes: Student Trustee, Levy, Ostini, Pensa, Zacarías

Noes: None

Abstentions: None

8. Public Comment

No public comment was made.

9. Approval of Minutes

9.A. Approval of Minutes from the May 20, 2025, regular board meeting

On a motion by Trustee Pensa, seconded by Trustee Ostini, the board of trustees voted to approve the minutes for the May 20, 2025, regular board meeting. (Ayes: Student Trustee, Levy, Ostini, Pensa, Zacarías; Noes: None; Absent: Enciso)

10. Presentations

10.A. Changing the Odds Moment

Trustee Levy shared the story of a student who, after spending a couple of years involved in campus clubs, including ASBG, was invited to join the Santa Barbara County Commission of Health and Human Services because of the experience she gained on campus.

Trustee Enciso arrived at 6:08 p.m.

11. Consent Agenda

Items 11.B., Approval of Employee Personnel Actions, and 11.J., Approval of 2027-2031 Five-Year Construction Plan, were moved before item 13.A.

On a motion by Trustee Levy, seconded by Trustee Pensa, the board of trustees voted to approve the revised consent agenda, on a roll-call vote as follows:

Ayes: Student Trustee, Enciso, Levy, Ostini, Pensa, Zacarías

Noes: None

Abstentions: None

12. Oral Reports

12.A. Superintendent/President's Report

On behalf of Superintendent/President Walthers, Dr. Curry acknowledged the efforts of Associate Superintendent/Vice President Curran's team for preparing the budget materials a week early to meet the revised board meeting date.

12.B. Board Member Reports

Trustee Zacarías was honored to attend the scholarship banquet, where she proudly awarded her family scholarship. She also attended the college's commencement ceremony.

Trustee Enciso reported she will be attending the West Coast College and University Wine Festival at Allan Hancock College on June 14.

Trustee Levy went to the Retirements and Recognitions Celebration, the scholarship banquet, the announcement of the Bachelor of Nursing degree, and the Paramedic Academy graduation. She encouraged everyone to attend the Wine Festival on June 14.

Trustee Ostini attended and spoke at the College Corps End-of-Year Celebration. He also attended the Retirement and Recognitions Ceremony and the Viticulture and Enology board meeting, where he was appointed board vice president.

Trustee Pensa attended commencement, the announcement of the Bachelor of Nursing degree, the Paramedic Academy graduation, and the Santa Barbara School Board Association meeting. He also thanked Rick Rantz for his hard work and collaboration over the years and congratulated him on his retirement.

Student Trustee Shrecengost said it has been an amazing year serving as student trustee. She expressed appreciation for all she has received from the college and thanked the board for their support in helping her serve her community.

12.C. Association Reports

1) Academic Senate

No Report

2) California School Employees Association

Toby McLaughlin thanked Human Resources for working with CSEA to place classified staff in other positions following a reduction in force due to decreased federal grant funding. He also thanked Ruben Ramirez, executive director, Human Resources and Labor Relations, for posting the video and materials from the benefits town hall. Mr. McLaughlin attended the CSEA Community College Forum and a field office training and said he is looking forward to the association's upcoming national conference.

3) Associated Student Body Government

Angela Ruiz shared ASBG hosted 83 events this year. She said she was honored to have received the Joe White and Marian Hancock scholarships. Ms. Ruiz noted that she is most proud of the Justice Impacted Summit this year. She thanked the board of trustees for their work on behalf of students.

4) AHC Foundation

No report

5) Management Association

No Report

6) Part-Time Faculty Association

No Report

7) Faculty Association

No Report

13. Action Items

11.B. Approval of Employee Personnel Actions

Janeal Blue, assistant director, Human Resources and Labor Relations, submitted Monica Thorpe for the board's approval for tenure track professor, early childhood studies.

On a motion by Trustee Levy, seconded by Trustee Pensa, the board of trustees voted to approve the appointment of Monica Thorpe, professor, early childhood studies. (Ayes: Student Trustee, Enciso, Levy, Ostini, Pensa, Zacarías; Noes: None; Absent: None)

11.J. Approval of 2027-2031 Five-Year Construction Plan

After discussion, on a motion by Trustee Levy, seconded by Trustee Enciso, the board of trustees voted to approve the 2027-2031 Five-Year Construction Plan. (Ayes: Student Trustee, Enciso, Levy, Ostini, Pensa, Zacarías; Noes: None; Absent: None)

13.A. Adoption of Resolution 25-26, Honoring Student Trustee

On a motion by Trustee Ostini, seconded by Trustee Enciso, the board of trustees adopted Resolution 25-26, Honoring Student Trustee on a roll-call vote as follows:

Ayes: Student Trustee, Enciso, Levy, Ostini, Pensa, Zacarías

Noes: None

Abstentions: None

13.B. Adoption of Resolution 25-27, Reduction in Classified Employees

On a motion by Trustee Enciso, seconded by Trustee Ostini, the board of trustees adopted Resolution 25-27, Reduction in Classified Employees on a roll-call vote as follows:

Ayes: Student Trustee, Enciso, Levy, Ostini, Pensa, Zacarías

Noes: None

Abstentions: None

13.C. Adoption of the 2025-2026 Tentative Budget

On a motion by Trustee Enciso, seconded by Trustee Levy, the board of trustees adopted the 2025-2026 Tentative Budget on a roll-call vote as follows:

Ayes: Student Trustee, Enciso, Levy, Ostini, Pensa, Zacarías

Noes: None

Abstentions: None

13.D. Acceptance of Grants Approved and Review of Grant Proposals Submitted

On a motion by Trustee Levy, seconded by Trustee Pensa, the board of trustees accepted the approved grants and the review of grants submitted. (Ayes: Student Trustee, Enciso, Levy, Ostini, Pensa, Zacarías; Noes: None; Absent: None)

13.E. Approval of Time Change for the July 15 Board Retreat

On a motion by Trustee Ostini, seconded by Student Trustee Shrecengost, the board of trustees voted to approve the time change for the July 15 Board Retreat. (Ayes: Student Trustee, Enciso, Ostini, Pensa, Zacarías; Noes: None; Abstention: Levy)

14. Information Items

14.A. First Review of K-12 CCAP Agreements with the School Districts

The board of trustees reviewed the K-12 CCAP Agreements with the School Districts.

14.B. Acceptance of Employee Retirement and Resignations

The board accepted the retirements and resignations of employees as presented.

14.C. 2027-2031 Deferred Maintenance Plan

The board of trustees did not suggest any changes to the Deferred Maintenance Plan.

14.D. First Review of Board Policy 3930, Minors on Campus

The board of trustees did not suggest changes to the board policy.

14.E. First Review of Administrative Procedure 5020, Nonresident Tuition

The board of trustees did not suggest changes to the administrative procedure.

14.F. First Review of Revised Administrative Procedure 5045, Student Records – Challenging Content and Access Log

The board of trustees did not suggest changes to the revised administrative procedure.

14.G. First Review of Revised Administrative Procedure 5050, Student Success and Support Program

The board of trustees did not suggest changes to the revised administrative procedure.

14.H. First Review of Revised Board Policy and Administrative Procedure 5410, Associated Student Elections

The board of trustees did not suggest changes to the revised board policy and administrative procedure.

14.I. First Review of Administrative Procedure 5520, Student Discipline Procedures

The board of trustees did not suggest changes to the administrative procedure.

14.J. Monthly Report, Associate Superintendent/Vice President, Academic Affairs

No oral report was given.

14.K. Monthly Report, Associate Superintendent/Vice President, Student Services

No oral report was given.

14.L. Monthly Report, Executive Director, Institutional Effectiveness

No oral report was given.

14.M. Monthly Report, Executive Director, College Advancement

No oral report was given.

14.N. Monthly Report, Associate Superintendent/Vice President, Finance and Administration

No oral report was given.

14.O. A Monthly Report on the Year-to-Date Financial Data for Various Funds

Associate Superintendent Curran gave a year-to-date overview of various funds. He noted that 100 percent of local revenue has been received, while only 67 percent of state revenue has been collected. State revenue is expected to reach 100 percent by the end of the fiscal year.

15. New Business

There were no requests for new business.

16. Calendar

Dr. Curry announced the opening of *Waitress* on June 19 in Solvang, followed by *Holmes and Watson* on June 26 in Santa Maria.

17. Adjournment

Trustee Zacarías adjourned the meeting at 7:02 p.m.

A handwritten signature in black ink, appearing to read 'KW', enclosed in a thin black rectangular border.

Kevin G. Walthers, Ph.D.
Secretary to the Board of Trustees

To: Board of Trustees	Date:
From: Superintendent/President	July 15, 2025
Subject: Register of Warrants and Payroll Summary 05/01/25 through 05/31/25	Item Number: 8.A.
Institutional Goal: Accreditation Standard III	Enclosures: Page 1 of 3 Full Warrant Register online

BACKGROUND

The following summary is submitted for board of trustees' approval. The full warrant register will be posted on the district's website in the electronic board agenda for review prior to the board meeting.

	<u>Fund Expenditures</u>	<u>Total Fund Expenditures</u>
General Fund 9410		
Invoice Warrants	\$ 3,619,556.53	
Payroll 05/01/25 – 05/31/25	7,718,836.83	
Total General Fund		\$ 11,338,393.36
Child Development Fund 9433		
Invoice Warrants	\$51,302.74	
Payroll 05/01/25 – 05/31/25	139,481.99	
Total Child Development Fund		190,784.73
Capital Projects Fund 9440		
Invoice Warrants	0.00	
Payroll 05/01/25 – 05/31/25	0.00	
Total Capital Projects Fund		0.00
Capital Outlay Projects Fund 9441		
Invoice Warrants	963,520.60	
Total Capital Outlay Projects Fund		963,520.60
Go Bond Building Fund 9447		
Invoice Warrants	14,591.62	
Total Go Bond Building Fund		14,591.62
Self-Insurance Dental Fund 9461		
Invoice Warrants	65,927.00	
Total Self-Insurance Dental Fund		65,927.00

(continued)

FISCAL IMPACT

None

RECOMMENDATION

Staff recommends that the board of trustees approve commercial warrants CT 25056753 through 25057493 and for a subtotal of \$4,752,648.49 and payroll warrants in the amount of \$7,858,318.82 for a grand total of \$12,610,967.31.

Administrator Initiating Item: Dennis D. Curran	Final Disposition:
--	--------------------

	<u>Fund Expenditures</u>	<u>Total Fund Expenditures</u>
Self-Insurance Property/Liability Fund 9463		
Invoice Warrants	37,750.00	
Total Self-Insurance Property/Liability Fund		37,750.00
Post-Employment Benefits Fund 9469		
Invoice Warrants	0.00	
Total Post-Employment Benefits Fund		0.00
Student Center Fee Trust Fund 9473		
Invoice Warrants	0.00	
Total Student Center Fee Trust Fund		0.00
<u>Grand Total All Funds</u>		<u>\$ 12,610,967.31</u>

ALLAN HANCOCK JOINT COMMUNITY COLLEGE DISTRICT
05/01/2025 - 05/31/2025
Payroll

General Fund 10

100 Academic Salaries

1100A	Academic Salaries Full Time	2,016,659.11
1100B	Administrators (Cert.) Non Teaching	293,685.39
1100D	Part Time Faculty	<u>1,019,071.34</u>
SUB TOTAL		<u>\$3,329,415.84</u>

200 Classified Salaries

2000A	CSEA	1,584,315.31
2000B	Confidential/Supervisory	221,184.75
2000C	Classified Administrators	305,854.11
2000E	Classified Hourly	182,472.49
2000F	Student Workers	271,180.60
2000G	Board Member	<u>1,389.15</u>
SUB TOTAL		<u>\$2,566,396.41</u>

300 Employee Benefits

3000A	STRS	508,687.89
3000B	PERS	574,469.56
3000C	OASDHI-FICA	210,867.74
3000D	Health & Welfare	465,351.59
3000E	EDD-SUI	2,695.17
3000F	Workers Comp	<u>60,952.63</u>
SUB TOTAL		<u>\$1,823,024.58</u>

TOTAL FUND 10 **\$7,718,836.83**

Child Development Fund 33

100 Academic Salaries

1100A	Academic Salaries Full Time	13,559.42
SUB TOTAL		<u>\$13,559.42</u>

200 Classified Salaries

2000A	CSEA	27,767.84
2000E	Classified Hourly	14,523.76
2000F	Student Workers	<u>62,171.24</u>
SUB TOTAL		<u>\$104,462.84</u>

300 Employee Benefits

3000A	STRS	2,551.08
3000B	PERS	9,828.19
3000C	OASDHI-FICA	3,997.81
3000D	Health & Welfare	3,798.84
3000E	EDD-SUI	27.59
3000F	Workers Comp	<u>1,256.22</u>
SUB TOTAL		<u>\$21,459.73</u>

TOTAL FUND 33 **\$139,481.99**

TOTAL DISTRICT PAYROLL **\$7,858,318.82**

Allan Hancock College

Warrant Register

Check Dates from 5/1/2025 to 5/31/2025

Bank Code: CT

Vendor Name	Description	Amount	Warrant
1000Bulbs.com	12 Volt 14Ah AGM Battery, BAT-10004	\$26.53	
	Shipping	\$7.99	
		\$34.52	CT 25056753
Aardvark Clay & Supplies, Inc	DuraKev Gloves 750degrees 18in	\$428.21	
	Raku Tongs 45degrees Jaws With Teeth 31in	\$352.78	
	Shipping	\$25.63	
		\$806.62	CT 25056754
AERA Engine Builders Association	AERA Membership Renewal-Member ID 3424	\$340.00	
	AERA Prosis Pro Software Subscription Renewal	\$530.00	
		\$870.00	CT 25056755
Sonia Aguirre	Reimbursement for instructional supplies 2/03/25	\$133.58	
		\$133.58	CT 25056756
AHC - District Trust Fund	Payroll Deduct 04.30.25 Management Association	\$210.00	
		\$210.00	CT 25056757
AHC Foundation	Payroll Deduct 04.30.25	\$3,127.96	
		\$3,127.96	CT 25056758
Rena Alspaw	PREPAY MEALS 5.08.25	\$299.31	
	PREPAY MEALS 5.08.25	\$303.38	
	PREPAY MEALS 5.08.25	\$299.31	
		\$902.00	CT 25056759
Amazon	Chemistry Lab Supplies: 7/01/24 - 5/30/25	\$165.37	
	Instructional Supplies 7/1/2024 - 5/31/2025	\$93.98	
	Office Supplies 7/02/24 - 5/30/25	\$333.56	
	Office Supplies - paper, paper clips, rubber bands	\$104.40	
	Office Operational Supplies from 7/1/24 to 5/30/25	\$41.29	
	Office/Operational supplies: 8/6/2024 - 5/30/2025	\$31.19	
	BOOKS FOR LIBRARY,	\$36.72	
	BOOKS FOR LIBRARY,	\$190.35	
	BOOKS FOR LIBRARY,	\$225.98	
	BOOKS FOR LIBRARY	\$53.27	
	INSTRUCTIONAL SUPPLIES OPEN UNTIL 5.30.25	\$73.08	
	Instructional Supplies for MESA/STEM,	\$980.34	
	Instructional supplies Oct 17, 2024 - May 30, 2025	\$77.16	
	Instructional supplies Oct 17, 2024 - May 30, 2025	\$42.37	
	Instructional supplies Oct 17, 2024 - May 30, 2025	\$66.70	
	Instructional Supplies: 12/16/24 - 5/30/25	\$392.58	
	Instructional Supplies: 12/16/24 - 5/30/25	\$392.58	
	Office Supplies: 07-01-24 to 05-30-25.	\$20.64	
	Office Supplies: 07-01-24 to 05-30-25.	\$83.39	
	Vet Tech Instructional Supplies: 1/29/25 - 5/30/25	\$365.40	
	Vet Tech Instructional Supplies: 1/29/25 - 5/30/25	\$394.40	
	Instructional Supplies 1/30/25-5/30/25	\$39.96	
	Office supplies and print shop supplies	\$148.00	
	Instructional Supplies: Flash Drives, 3/06/25 -	\$24.26	
	Instructional Supplies 3/07/2025 - 5/30/2025	\$114.24	

Allan Hancock College

Warrant Register

Check Dates from 5/1/2025 to 5/31/2025

Bank Code: CT

Vendor Name	Description	Amount	Warrant
Amazon	Office Supplies, 3-11-25 to 5-30-25	\$27.61	
	Office Operational Supplies for FCS, 3/18/25 -	\$86.99	
	LVC LRC Lola Dority book funds 3.25.25 - 5.30.25	\$190.60	
	Supplies for ITS: 3/24/25 - 5/30/25	\$76.82	
	Supplies for ITS: 3/24/25 - 5/30/25	\$90.88	
	Supplies for ITS: 3/24/25 - 5/30/25	\$40.21	
	Supplies for ITS: 3/24/25 - 5/30/25	\$266.73	
	BOOKS FOR LIBRARY, 3/25/25 - 5/30/25	(\$32.79)	
	BOOKS FOR LIBRARY, 3/25/25 - 5/30/25	\$126.74	
	BOOKS FOR LIBRARY, 3/25/25 - 5/30/25	\$871.74	
	BOOKS FOR LIBRARY, 3/25/25 - 5/30/25	\$965.24	
	INSTRUCTIONAL SUPPLIES 07-02-24 TO 05-30-25	\$764.70	
	LE INSTRUCTIONAL SUPPLIES: 07-02-24 TO 05-30-25	\$411.71	
	LE INSTRUCTIONAL SUPPLIES: 07-02-24 TO 05-30-25	\$663.40	
	LE INSTRUCTIONAL SUPPLIES: 07-02-24 TO 05-30-25	\$843.42	
	Office Operational Supplies from 7/1/24 to 5/30/25	(\$43.48)	
	Operational Supplies - Grounds, 10/02/24 - 5/30/25	\$201.02	
	Operational-Office Supplies 12-10-25 to 05-30-25	\$29.35	
	Operational-Office Supplies 12-10-25 to 05-30-25	\$39.97	
	Awards Banquet supplies May 2, 2025	\$338.94	
	Decorations and Prizes for Noncredit Recognition	\$409.65	
	LVC Library Books 4.1.25 - 5.30.25	\$313.47	
	8980 Sharps container 8 gallon	\$89.30	
	Tempa Dot	\$99.07	
	Sharps Container 5 quart	\$83.84	
	Medline Electrodes Adult	\$31.42	
	Luer Lock Tip Syringes no needle	\$65.21	
	Medical Gloves size 8.5	\$78.26	
	Exam Gloves Large	\$312.68	
	Alcohol Prep Pads	\$32.51	
	4mm Tip Caps Green	\$52.68	
	Medical Gloves size 7	\$73.93	
	Exam Gloves Medium	\$421.95	
	ECG Thermal Paper Roll 110mm	\$54.32	
	Medical Gloves size 7.5	\$78.28	
	Science Lab Labeling Tape Variety Pack	\$99.99	
	Inspire Nitrile Gloves Medium	\$75.35	
	Inspire Nitrile Gloves Small	\$75.34	
	Graduation Stoles for Spring 2025 Noncredit	\$965.40	
	Film Instructional Supplies, 4/8/25 - 5/30/25	\$59.81	
	Film Instructional Supplies, 4/8/25 - 5/30/25	\$212.90	
	Instructional Supplies Valid 4-8-2025 To 5-30-2025	\$384.34	
	Instructional Supplies Valid 4-8-2025 to 5-30-2025	\$681.91	
	Swiffer mop pad refill	\$130.48	
	Glass cleaner	\$8.09	
	Expo dry erase marker blk	\$25.54	
	Tool Bag	\$24.01	
	Clorox toilet cleaner	\$5.42	
	20x30 Easel sticky pads	\$95.70	
	Swiffer solution	\$37.74	
	Pentel pens	\$19.13	

Allan Hancock College

Warrant Register

Check Dates from 5/1/2025 to 5/31/2025

Bank Code: CT

Vendor Name	Description	Amount	Warrant
Amazon	Kleenex	\$54.38	
	Expansion file folder purple	\$23.24	
	Shop towels	\$42.39	
	Expansion File Folder Blue	\$22.13	
	Clorox surface cleaner	\$17.39	
	Battery AA & AAA bundle	\$88.78	
	Dry erase board spray	\$36.50	
	Lens Cleaner Wipes	\$18.48	
	Plastic spray bottles	\$10.86	
	Purell hand sanitizer singles	\$31.30	
	Flushable wipes individual	\$36.95	
	Swiffer mop	\$30.71	
	Totally Awesome cleaner	\$28.87	
	Instructional Supplies, 4/11/25 - 5/30/25. Dept.	\$29.47	
	Instructional supplies 4/11/2025-5/30/2025	\$17.09	
	Instructional Supplies, 4/11/25 - 5/30/25	\$178.99	
	Ceramic Instructional Supplies 4/14/2025-5/30/2025	\$73.18	
		\$16,289.44	CT 25056760
American Business Machines	Copier maintenance for Canon iR 1643iF, ID #16098,	\$216.89	
	Copier Annual Maintenance:	\$7.12	
	\$224.01	CT 25056761	
American Fidelity Assurance Co	employee premiums Voluntary Plans April 2025	\$38,899.55	
		\$38,899.55	CT 25056762
	employee premiums Flexible Spending April 2025	\$13,642.63	
	\$13,642.63	CT 25056763	
	employee premiums HSA accounts APR 2025	\$8,777.25	
	\$8,777.25	CT 25056764	
American General Media Inc.	30-Second Ad Spring 2025 Registration	\$50.00	
	30-Second Ad Spring 2025 Registration	\$50.00	
	\$100.00	CT 25056765	
American Heart Association, Inc	BLS Provider eCard	\$680.00	
		\$680.00	CT 25056766
American Industrial Supply	Supplies for Maintenance, 11.14.2024 to 5.30.2025	\$17.23	
	Supplies for Maintenance, 11.14.2024 to 5.30.2025	\$112.12	
		\$129.35	CT 25056767
	Operational Supplies for Fire Academy	\$173.11	
	\$173.11	CT 25056768	
American Star Tours, Inc.	Bus Service - AHC Softball on 4-10-25	\$2,220.00	
	Bus Service - AHC Baseball on 4-8-25	\$1,735.00	
	Bus Service - AHC Baseball on 4-12-25	\$1,735.00	
	Bus Service - AHC Track on 4-18-25	\$1,995.00	
	Bus Service - AHC Baseball on 4-18-25	\$2,220.00	

Allan Hancock College

Warrant Register

Check Dates from 5/1/2025 to 5/31/2025

Bank Code: CT

Vendor Name	Description	Amount	Warrant
		\$9,905.00	CT 25056769
Applied Industrial Technologies - CA LLC	Single Row Ball Bearings per Invoice 7031743824	\$73.10	
	Shipping and Handling	\$17.79	
		\$90.89	CT 25056770
Assoc CA Community College Admin	Payroll Deduct 04.30.25	\$109.89	
		\$109.89	CT 25056771
B & B Steel & Supply	Instructional Supplies for Welding, Invoice #	\$102.28	
		\$102.28	CT 25056772
B&H Photo Video	Photo Instructional Supplies 1/23/2025-5/30/2025	\$1,069.11	
		\$1,069.11	CT 25056773
Bauer Compressors, Inc	Annual PM Service for Bauer Compressor Serial No.	\$1,789.04	
		\$1,789.04	CT 25056774
Bell, McAndrews and Hiltachk, LLP	Legal Services Invoice # 7777.263-1102	\$785.40	
		\$785.40	CT 25056775
Benevolent & Protective Order Of The Elks #1538	2025 Rodeo Parade Historical Moments Sponsor	\$1,500.00	
		\$1,500.00	CT 25056776
Big Brand Tire Company	LT245/75R16 Roadian Tires	\$669.03	
	Tire Recycling	\$22.00	
	Road Force Wheel Balance	\$99.00	
	Premium Wheel Weights	\$18.00	
	CA State Tire Fee	\$7.00	
	Extended Warranty	\$144.00	
		\$959.03	CT 25056777
Blick Art Materials	BLICK STAINLESS STEEL 18IN	\$36.19	
	BLICK STAINLESS STEEL 12IN	\$36.15	
	CLEARPRINT 1000H 8.5X11 100/SHT ZZ	\$200.36	
	BLICK CUTTING MAT 18X24 TRANS	\$67.05	
	BLICK CUTTING MAT 24X36 GRY/BLK	\$62.73	
	ARCHES COVER PAPER I3 BLK 22X30 92LB	\$162.69	
		\$565.17	CT 25056778
Bowls On The Go	Food Purchase for "Puentor Interviews" Event	\$619.88	
	Delivery Fee	\$20.00	
		\$639.88	CT 25056779
Bremer Auto Parts	Operational Supplies for Fire Academy	\$9.14	
	Supplies/parts for LE vehicles: 7/02/24 - 5/30/25.	\$52.12	
	Supplies/parts for LE vehicles: 7/02/24 - 5/30/25.	\$160.49	
	Supplies/parts for LE vehicles: 7/02/24 - 5/30/25.	\$140.60	
	Supplies/parts for LE vehicles: 7/02/24 - 5/30/25.	\$202.46	
		\$564.81	CT 25056780

Allan Hancock College

Warrant Register

Check Dates from 5/1/2025 to 5/31/2025

Bank Code: CT

Vendor Name	Description	Amount	Warrant
C.S.E.A. Chapter 251 Dues - AHC	Payroll Deduct 04.30.25	\$490.00	
		\$490.00	CT 25056781
C.S.E.A. Victory Club	Payroll Deduct 04.30.25	\$171.50	
		\$171.50	CT 25056782
CA School Employees Association	Payroll Deduct 04.30.25	\$9,195.11	
		\$9,195.11	CT 25056783
Ca Schools Dental Coalition	dental insurance Premiums MAY 2025	\$65,927.00	
		\$65,927.00	CT 25056784
Cabrillo Community College District	Cost-Reimbursement Subaward Agreement for	\$5,767.02	
		\$5,767.02	CT 25056785
Cal Oes	26-50 FRO-PB Certificates from CSTI for CRN: 40755	\$160.00	
	Additional Fee for Pro Board Certificates	\$256.00	
		\$416.00	CT 25056786
	26-50 FRO-D Certificates from CSTI for CRN: 40756	\$160.00	
		\$160.00	CT 25056787
	26-50 FRO-WMD Certificates from CSTI for	\$160.00	
		\$160.00	CT 25056788
Cal State Auto Parts	Battery and Battery Core per Invoice 326856	(\$9.79)	
	Battery and Battery Core per Invoice 326856	\$142.70	
	Calif Battery Fee	\$2.00	
	Air Filter per Invoice 327647	\$36.87	
	Oil per Invoice 327536	\$94.98	
	Switch ASM OS RR View Mir per Invoice 328697	\$36.91	
	Module Kit, F/Tnk, F/Pmp per Invoice 326745	\$290.40	
		\$594.07	CT 25056789
California Nature Art Museum	REC 109 Group Admission to Cali Nature Art Museum.	\$30.00	
	TABLE SPONSORSHIP - 25TH ANNIVERSARY CELEBRATION	\$1,250.00	
		\$1,280.00	CT 25056790
Carolina Biological	Biology Labs Supplies: 07-01-24 thru 05-31-25	\$29.75	
	Biology Labs Supplies: 07-01-24 thru 05-31-25	\$33.44	
	Biology Labs Supplies: 07-01-24 thru 05-31-25	\$53.77	
	Biology Labs Supplies: 07-01-24 thru 05-31-25	\$328.65	
		\$445.61	CT 25056791
Child Educational Center	OCP Professional Development Certification:	\$1,500.00	
		\$1,500.00	CT 25056792
City Motors Towing Inc	Transport Toyota Fork-Lift from McElhaney Ave. &	\$145.00	
		\$145.00	CT 25056793
Coastal Reprographic Services	Large Format Scanning, 11/12/2024 - 5/30/2025	\$385.76	

Allan Hancock College

Warrant Register

Check Dates from 5/1/2025 to 5/31/2025

Bank Code: CT

Vendor Name	Description	Amount	Warrant
		\$385.76	CT 25056794
Column Software PBC	Legal Advertising of the PSTC Restroom Building	\$924.60	
		\$924.60	CT 25056795
County of Santa Barbara	Permit Fee for Registration Renewal (Annual)	\$277.60	
		\$277.60	CT 25056796
Dept Of Forestry & Fire Protection	Confined Space Rescue Awareness - CSRA1550 B155	\$2,250.00	
		\$2,250.00	CT 25056797
Earth Systems Pacific	Provide on-site soil and material special Geotechnical Engineering and Engineering Geology	\$4,297.00	
		\$5,000.00	
		\$9,297.00	CT 25056798
Ellucian Company LLC	Online Class: Banner Graduation Officers Learning	\$400.00	
		\$400.00	CT 25056799
Envoy Plan Services Inc.	Payroll Deduct 04.30.25	\$135,178.75	
		\$135,178.75	CT 25056800
FACCC Fac Assoc CA Comm Colleges	Payroll Deduct 04.30.25	\$239.00	
		\$239.00	CT 25056801
Faculty Association of AHCC	Payroll Deduct 04.30.25	\$9,980.03	
		\$9,980.03	CT 25056802
Federal Express Corp	Mailings for Acct #1104-8488	\$9.77	
		\$9.77	CT 25056803
Fisher Scientific Co Llc	FisherBrand Sharps Container	\$12.42	
		\$12.42	CT 25056804
Follett Heg - Ahc Bookstore	spring 2025 inclusive access program	\$3,108.40	
		\$3,108.40	CT 25056805
	Book Voucher for NextUp Students, ending 6-30-25	\$2.91	
		\$2.91	CT 25056806
	EOPS Student Supplies for Spring 2025	\$1,120.79	
		\$1,120.79	CT 25056807
	EOPS Book Vouchers for Spring 2025	\$3,040.63	
		\$3,040.63	CT 25056808
Foodbank Of Santa Barbara County	Food for Foodshare and Basic Needs Food Pantry for	\$971.62	
	Food for Foodshare and Basic Needs Food Pantry for	\$3,453.91	
	Food for Foodshare and Basic Needs Food Pantry for	\$1,121.14	
		\$5,546.67	CT 25056809
	Food for Foodshare and Basic Needs Food Pantry for	\$423.07	
	Food for Foodshare and Basic Needs Food Pantry for	\$20.00	
	Food for Foodshare and Basic Needs Food Pantry for	\$721.52	
	Food for Foodshare and Basic Needs Food Pantry for	\$45.60	

Allan Hancock College

Warrant Register

Check Dates from 5/1/2025 to 5/31/2025

Bank Code: CT

Vendor Name	Description	Amount	Warrant
		\$1,210.19	CT 25056810
Franchise Tax Board	Payroll Deduct 04.30.25	\$886.85	
		\$886.85	CT 25056811
	Payroll Deduct 04.30.25 Court Order Collections	\$81.89	
		\$81.89	CT 25056812
Friends Beauty Supply Inc	TB-1 Ben Nye Thick Blood 1 oz	\$52.20	
	SP-500 Ben Nye Creme Stack SP-500 Primary	\$104.40	
	TK-3 Ben Nye Theatrical Creme Kit Olive Light-	\$424.13	
	TK-2 Ben Nye Theatrical Creme Kit Fair: Medium-Tan	\$424.13	
	TK-1 Ben Nye Theatrical Creme Kit Fair: Light-Med	\$424.13	
	WK-11 Ben Nye Character Wheel Clown	\$313.20	
	LW Ben Nye Wheel Lumiere Creme	\$208.80	
	LKP-1 Ben Nye Creme Palette Primary	\$261.00	
	RW BN Pro Wheel Rainbow	\$243.60	
	LCP-1 Ben Nye Lumiere Creme Palette	\$678.60	
	TS-1 Ben Nye Fresh Scab 1 oz	\$104.40	
	SB-2 Ben Nye Stage Blood .5 oz	\$30.45	
	Fedex Ground Shipping and Delivery	\$53.99	
		\$3,323.03	CT 25056813
Grainger Inc.	Maintenance Supplies 3.6.2025 to 5.30.2025	\$97.85	
		\$97.85	CT 25056814
Hayward Lumber Inc	Hardware-Lumber Supplies, 07-01-24 thru 05-31-25	\$43.45	
	Hardware-Lumber Supplies, 07-01-24 thru 05-31-25	\$50.98	
		\$94.43	CT 25056815
Henry Schein Inc	Cando Gel Hand Ball Small Red Light Item #3920029	\$5.08	
	Cando Gel Hand Ball Small Blk X Heavy Item	\$5.08	
	Dura Stick II Electrode	\$128.87	
	Gatorade Clown Nose Spigo Item #1464086	\$43.80	
	Premium Gauze Sponge Item #5702631	\$97.22	
	Spenco 2nd Skin Item #6452314	\$49.94	
	Tape Zinc Oxide M Tape Item #3648036	\$352.67	
	Flex All Splint Item #4992562	\$22.97	
	Cando Gel Hand Ball Small Green Item #3920030	\$5.08	
	Cando Gel Hand Ball Blue Item #3920031	\$5.08	
	Coolant Cold Spray Item #1367746	\$10.70	
		\$726.49	CT 25056816
Home Depot	Supplies per Invoice 1892756	\$175.08	
	Supplies per Invoice 9026684	\$65.16	
	Supplies per Invoice 20591	\$48.14	
	Supplies per Invoice 3722051	\$440.22	
	Supplies per Invoice 3037237	\$64.20	
	Supplies per Invoice 1516208	\$45.59	
	Supplies per Invoice 8542369	\$302.28	
	Supplies per Invoice 5542683	\$52.19	
	Supplies per Invoice 2195702	\$26.49	
	Supplies per Invoice 7520024	\$27.99	
	Supplies per Invoice 7513069	\$31.50	

Allan Hancock College

Warrant Register

Check Dates from 5/1/2025 to 5/31/2025

Bank Code: CT

Vendor Name	Description	Amount	Warrant
Home Depot	Supplies per Invoice 3542874	\$32.91	
	Supplies per Invoices 2523114	\$39.44	
	Supplies per Invoice 3039450	\$39.66	
	Supplies per Invoice 7531437	\$44.54	
	Supplies per Invoice 4522785	\$47.81	
	Supplies per Invoice 2534788	\$62.22	
	Supplies per Invoice 7030261	\$84.83	
	Supplies per Invoice 2356396	\$110.49	
	Supplies per Invoice 7331546	\$121.58	
	Supplies oer Invoice 1393902	\$271.60	
	Supplies per Invoice 3183698	\$293.53	
	Supplies per Invoice 7127952	\$307.43	
	Supplies per Invoice 21705	\$345.08	
	Concrete Mix per Invoice 4243801	\$130.33	
	Instructional Supplies for Fire Academy	\$8.63	
	Chemistry Lab Supplies: 7/01/24 - 5/30/25	\$86.91	
	Instructional Supplies for Fire Academy	\$33.17	
	Department supplies from 7/01/24 - 5/30/25	\$222.86	
		\$3,561.86	
Intermountain Lock And Security Supply	Keypad Reader Module for AD-Series Lock, Item ID:	\$4,281.37	
	Key and Lock Supplies, 02-12-25 thru 5-30-25	\$238.74	
	Key and Lock Supplies, 02-12-25 thru 5-30-25	\$122.44	
	Key and Lock Supplies, 02-12-25 thru 5-30-25	\$154.04	
	\$4,796.59		CT 25056818
IRS ACS Support	Payroll Deduct 04.30.25	\$101.75	
		\$101.75	CT 25056819
Richard Jacoby	Guest Artist installation and discussion at the	\$200.00	
		\$200.00	CT 25056820
Kaplan Early Learning Co	Supplies for Children's Center per quote #545772	\$1,092.60	
		\$1,092.60	CT 25056821
Erin Krier	Reimbursement for AHC FFA Day Supplies	\$546.11	
		\$546.11	CT 25056822
La Tapatia Bakery	Food Purchase for the "Coachella y Chisme" Event	\$536.50	
	Food Purchase for the Coachella y Chisme Event	\$226.20	
	Food Purchase for Registration Counseling Event	\$99.50	
	\$862.20		CT 25056823
Lakeshore Learning Materials LLC	Operational Supplies for Children's Center per	\$18.55	
	STORE AND EXPLORE PLAY MAT Item # AA807, per Quot	\$1,195.16	
	OUTDOOR PRETEND-PLAY MARKET Item #LK174	\$1,521.41	
	Freight	\$374.71	
	SENSORY HIDEAWAY, Item #LC965, per Quote #20020940	\$1,412.66	
	FREIGHT	\$194.85	
	\$4,717.34		CT 25056824
Linde Gas & Equipment Inc.	Instructional Supplies:	\$588.06	

13-10
Allan Hancock College
Warrant Register
Check Dates from 5/1/2025 to 5/31/2025
Bank Code: CT

Vendor Name	Description	Amount	Warrant
Linde Gas & Equipment Inc.	Instructional Supplies 02/07/25 - 05/30/25	\$956.13	CT 25056825
	Supplies for the Chem Labs 11-20-24 thru 05-30-25.	\$7.31	
		\$1,551.50	
Looking Glass Media LLC	30-second Ad 2025 Summer Fall Registration	\$1,175.00	CT 25056826
		\$1,175.00	
Kristen Marshall	PAYROLL DEDUCTION 04/30/2025	\$1,600.00	CT 25056827
		\$1,600.00	
Metropolitan Life Insurance Co	INSURANCE PREMIUMS APR 2025	\$7,279.64	CT 25056828
		\$7,279.64	
Mission Linen Supply	Laundry Services for Automotive Collision Repair:	\$21.13	CT 25056829
	Laundry Services for Automotive Technology Program	\$34.60	
	Kitchen linen service for Culinary Arts,	\$47.00	
	Kitchen linen service for Culinary Arts,	\$47.00	
	Kitchen linen service for Culinary Arts,	\$47.00	
	Uniform Services and Towels, 7-01-24 thru 6-30-25	\$22.89	
	Uniform Services and Towels, 7-01-24 thru 6-30-25	\$22.89	
	Uniform Services and Towels, 7-01-24 thru 6-30-25	\$22.89	
		\$265.40	
Marguerite Moreton	Reimbursement for pizza purchased for Pride	\$48.07	CT 25056830
		\$48.07	
Niles Biological	Science Lab Supplies July 1, 2024-May 30, 2025	\$40.21	CT 25056831
	Instructional Supplies for Biology Labs:	\$66.34	
		\$106.55	
Noble Power Equipment	Supplies per Invoice 642259	\$11.45	CT 25056832
	Supplies per Invoice 645049	\$205.60	
	Carburetor WTA-35 per Invoice 647719	\$59.23	
	Supplies per Invoice 1400377	\$20.36	
		\$296.64	
ODP Business Solutions LLC	Brother ME-793 Black-on-pink-green-silver	\$30.11	
	Office Depot paperclips, tub of 1000	\$2.13	
	Office Depot staples, 5,000 per box	\$4.77	
	TUL BP Series Retractable Ballpoint Pens	\$10.65	
	Office Depot Sticky Notes, 1-1/2" x 2"	\$13.47	
	Operational Supplies: 7/12/24 - 5/30/25	\$21.47	
	Office/Operational Supplies for the MESA/STEM	\$14.92	
	Office/Operational Supplies for the MESA/STEM	\$78.40	
	Office/Operational Supplies for the MESA/STEM	\$496.28	
	Office/Operational Supplies for the MESA/STEM	\$35.43	
	Office/Operational Supplies for the MESA/STEM	\$362.04	
	Office Supplies for Transfer Center, 3/28/25 -	\$29.21	
	Office Supplies 11-08-2024 through 5-30-2025	\$19.89	
	OFFICE SUPPLIE FOR LE, 4/14/25 - 5/30/25	\$379.99	
	Open PO for Department Chair	\$1,175.26	
Open PO for Department Chair	\$2,150.49		
Open PO for Department Chair	\$34.68		
Instructional Supplies, 1/31/25 to 5/30/25	\$118.50		

Allan Hancock College

Warrant Register

Check Dates from 5/1/2025 to 5/31/2025

Bank Code: CT

Vendor Name	Description	Amount	Warrant
ODP Business Solutions LLC	Office Operational Supplies for FSN,	\$162.54	
		\$5,140.23	CT 25056833
OTM Furniture Installations	Delivery/Installation Services for 15 Intandem	\$752.00	
		\$752.00	CT 25056834
Out Fit	Rubber Hex Dumbbell 20lb each	\$705.02	
		\$705.02	CT 25056835
PARS Public Agency Retirement	PAYROLL DEDUCTION 04/30/2025	\$8,317.86	
		\$8,317.86	CT 25056836
Part Time Faculty AHC - Member	PAYROLL DEDUCTION 04/30/2025	\$10,085.21	
		\$10,085.21	CT 25056837
Proquest Llc	BOOKS FOR LIBRARY: 3/18/25 - 5/30/25	\$58.24	
	BOOKS FOR LIBRARY: 3/18/25 - 5/30/25	\$37.89	
	BOOKS FOR LIBRARY: 3/18/25 - 5/30/25	\$97.99	
	BOOKS FOR LIBRARY: 3/18/25 - 5/30/25	\$301.71	
		\$495.83	CT 25056838
San Luis Obispo County Community College District	Cost-Reimbursement Subaward Agreement for	\$1,028.06	
		\$1,028.06	CT 25056839
Santa Barbara County Sheriff	PAYROLL DEDUCTION 04/30/2025	\$476.59	
		\$476.59	CT 25056840
Santa Barbara County Sheriff's Office	PAYROLL DEDUCTION 04/30/2025	\$960.53	
		\$960.53	CT 25056841
Santa Maria Breakfast Rotary Club	2025 BARN PARTY SPONSORSHIP	\$5,000.00	
		\$5,000.00	CT 25056842
SLO Safe Ride	Bus Charter for Pinnacles National Park and	\$2,505.00	
		\$2,505.00	CT 25056843
Sousa Tire Service	Tire recycling 12-16-24 to 5-30-25	\$40.50	
		\$40.50	CT 25056844
St. Mary Of The Assumption School	Basic Needs Student Emergency Gas Cards-	\$20,000.00	
	Basic Needs Student Emergency Little Caesars Gift	\$5,000.00	
	Basic Needs Student Emergency Visa Gift Cards	\$1,000.00	
	Basic Needs Student Emergency Walmart Cards	\$5,000.00	
		\$31,000.00	CT 25056845
Sterling Communications	Radios - Mototrbo R2 UHF, Item #AAH11TDC9JC2AN,	\$3,915.00	
		\$3,915.00	CT 25056846
Testa Catering	Food Purchase for Registration Counseling Event	\$307.46	
	Operations Fee	\$36.18	
	Delivery Fee	\$54.37	

13-12
Allan Hancock College
Warrant Register
 Check Dates from 5/1/2025 to 5/31/2025
 Bank Code: CT

Vendor Name	Description	Amount	Warrant
		\$398.01	CT 25056847
Texas Life Insurance Co.	INSURANCE PREMIUMS APR 2025	\$14,037.01	
		\$14,037.01	CT 25056848
The Berry Man Inc	Instructional Food Supplies for Culinary Arts:	(\$21.95)	
	Instructional Food Supplies for Culinary Arts:	\$126.35	
	Instructional Food Supplies for Culinary Arts:	\$45.85	
		\$150.25	CT 25056849
The Shack of Lompoc, Inc.	Graduation Pins for Medical Assistant Program	\$182.47	
		\$182.47	CT 25056850
Uline Inc	Bindery Supplies, Lamination	\$1,367.98	
	Supplies for Basic Needs Pantry and Center,	\$457.96	
	Supplies for Basic Needs Pantry and Center,	\$646.09	
	Supplies for Basic Needs Pantry and Center,	\$704.81	
		\$3,176.84	CT 25056851
United Site Services Of California Inc	Services - 3 Portable Toilets, 7-1-24 thru 6-30-25	\$627.00	
		\$627.00	CT 25056852
United Way of the Central Coast	PAYROLL DEDUCTION 04/30/2025	\$30.00	
		\$30.00	CT 25056853
Oxnard College	Cost-reimbursement Subaward Agreement for	\$1,134.84	
	Cost-reimbursement Subaward Agreement for	\$10,650.14	
		\$11,784.98	CT 25056854
VTC Enterprises	3" Buttons for Hancock Hello: Design Fee.	\$18.00	
	Print in Color Single-Sided (under 250)	\$4.18	
	White 28/70lb Paper	\$0.87	
	Die Cut Sheets	\$9.85	
	Assemble 3" Buttons (under 100)	\$113.97	
		\$146.87	CT 25056855
Ward's Science Inc	Supplies for Biology Labs: 07-05-24 thru 05-30-25	\$15.48	
		\$15.48	CT 25056856
Wex Bank	Gas Credit Card Purchases, 03-01-25 thru 6-30-25	\$477.93	
		\$477.93	CT 25056857
Yankee Book Peddler Inc	BOOKS FOR LIBRARY	\$111.06	
	BOOKS FOR LIBRARY, 3/18/25 - 5/30/25	\$1,658.96	
		\$1,770.02	CT 25056858
Lorenzo Abraham Tomasa	Manual Refund Submitted	\$500.00	
		\$500.00	CT 25056859
Daniel Acosta Acosta	Manual Refund Submitted	\$28.00	
		\$28.00	CT 25056860
Ana Cardenas	Manual Refund Submitted	\$1,848.00	

13-13
Allan Hancock College
Warrant Register
Check Dates from 5/1/2025 to 5/31/2025
Bank Code: CT

Vendor Name	Description	Amount	Warrant
		\$1,848.00	CT 25056861
Chad Mowry	Manual Refund Submitted	\$28.00	
		\$28.00	CT 25056862
Jennie Robertson	Manual Refund Submitted	\$75.00	
		\$75.00	CT 25056863
Jacqueline Salvador	Manual Refund Submitted	\$172.00	
		\$172.00	CT 25056864
Alex Sanchez Aguilar	Manual Refund Submitted	\$412.00	
		\$412.00	CT 25056865
Gavin Shorts	Manual Refund Submitted	\$1,001.00	
		\$1,001.00	CT 25056866
Anthony Tapia Corona	Manual Refund Submitted	\$610.00	
		\$610.00	CT 25056867
Gustavo Trejo	Manual Refund Submitted	\$2,144.00	
		\$2,144.00	CT 25056868
Andrea Cabanas	Open Mileage 4.1-29.25	\$134.96	
	Open Mileage 3.4,11,13,18.25	\$310.52	
		\$445.48	CT 25056869
Carla Castillo	ACHRO PD Cerritos, CA	\$1,136.41	
		\$1,136.41	CT 25056870
City of Lompoc	Waste Disposal-Sewer Fees 7.1.2024 - 6.30.2025	\$619.80	
	Water Services 7.1.2024 - 6.30.2025	\$4,478.07	
		\$5,097.87	CT 25056871
	Waste Disposal-Sewer Fees 7.1.2024 - 6.30.2025	\$1,763.06	
		\$1,763.06	CT 25056872
	Commercial Light Electric 7.1.2024 - 6.30.2025	\$21,605.89	
		\$21,605.89	CT 25056873
Joanna Davis	CCCCO Sacramento, CA	\$343.21	
		\$343.21	CT 25056874
Digital West Networks, Inc	Telephone Service 7/1/2024 - 6/30/2025	\$4,167.50	
	Telephone Service 7/1/2024 - 6/30/2025	\$1,574.74	
	Telephone Service 7/1/2024 - 6/30/2025	\$1,435.57	
		\$7,177.81	CT 25056875
	Internet Service 7/1/2024 - 6/30/2025	\$145.00	
		\$145.00	CT 25056876
Disneyland Resort	Ticket Registration Disneyland 6.30.25 Segura,M	\$9,923.00	
		\$9,923.00	CT 25056877
Kim Ensing	3C2A Convention Sacramento, CA	\$503.44	
		\$503.44	CT 25056878
Susana Garcia	Open Mileage 3.05,7,14,19,25.25	\$34.30	

13-14
Allan Hancock College
Warrant Register
Check Dates from 5/1/2025 to 5/31/2025
Bank Code: CT

Vendor Name	Description	Amount	Warrant
		\$34.30	CT 25056879
Christine Grelck	Open Mileage 4.04.25	\$36.68	
		\$36.68	CT 25056880
Domitre Grinder	Open Mileage 3.13,27.25	\$4.76	
		\$4.76	CT 25056881
James Guzman	Open Mileage 4.8-4.18.25	\$15.96	
		\$15.96	CT 25056882
Lisa Hernandez	Open Mileage 4.14.25	\$36.54	
		\$36.54	CT 25056883
Melinda Martinez	Open Mileage 10.11,15.24	\$0.00	
	Open Mileage 10.11,15.24	\$3.48	
	Open Mileage 1.01-4.30.25	\$9.94	
	Open Mileage 1.01-4.30.25	\$99.12	
		\$112.54	CT 25056884
Toby McLaughlin	Open Mileage 4.7,14,21,28,29.25	\$164.15	
		\$164.15	CT 25056885
Paul Meddings	Pesticide Renuwal Certification Santa Maria, CA	\$148.86	
		\$148.86	CT 25056886
Marisela Medina	Open Mileage 7.5-12.02.24	\$222.04	
		\$222.04	CT 25056887
Marguerite Moreton	Open Mileage 4.18.25	\$39.20	
		\$39.20	CT 25056888
Trevor Passage	Open Mileage 4.2-28.25	\$123.97	
	Open Mileage 4.2-28.25	\$0.00	
		\$123.97	CT 25056889
Greg Pensa	Oct 25 \$844.51 Nov 25 \$379.96 Airfare reimburse	\$1,224.47	
		\$1,224.47	CT 25056890
Thesa Roepke	Open Mileage 10.29.24	\$67.80	
		\$67.80	CT 25056891
Southern California Gas Co	Natural Gas Supply 7/01/2024 - 6/30/2025	\$3,877.06	
	Natural Gas Supply 7/01/2024 - 6/30/2025	\$794.10	
		\$4,671.16	CT 25056892
Brian Stokes	ANTH 103 Field Trip Santa Barbara, CA	\$99.70	
		\$99.70	CT 25056893
Anabel Suarez Guzman	Open Mileage 4.16.25	\$40.46	
		\$40.46	CT 25056894
Gabriella Trevino	Open Mileage 3.27,30,4.13.25	\$60.90	
	Open Mileage 12.06.25 4.14.25	\$39.31	
		\$100.21	CT 25056895
Lilia Wambolt	Open Mileage 3.29, 4.01,4.23.25	\$64.19	

13-15
Allan Hancock College
Warrant Register
Check Dates from 5/1/2025 to 5/31/2025
Bank Code: CT

Vendor Name	Description	Amount	Warrant
		\$64.19	CT 25056896
Jeremy Wirth	Photo Shoot Commercial Truck LVC	\$35.28	
		\$35.28	CT 25056897
19six Architects	Amendment #2 for Reimbursement of DSA Fees Paid	\$2,642.50	
	Bidding	\$558.75	
	Bidding	\$0.00	
	Schematic Design	\$13,035.00	
	Design Development	\$14,770.00	
		\$31,006.25	CT 25056898
4imprint Inc.	Hang In There Reflective Lanyard - 40" Item #	\$5,578.88	
	Set-Up	\$59.81	
	Freight	\$113.64	
	Mini Stylus Pen with Phone Stand and Screen	\$2,838.38	
	Set-Up Charge	\$21.75	
	Freight	\$73.03	
	Vinyl Certificate Holder #144681	\$388.78	
	Freight	\$37.67	
	Pierce Jade Award 7" (139040-7). Color: Clear/	\$292.00	
	Set-Up Charge	\$38.06	
	Freight	\$12.49	
	Lunch Time Cutlery Set, Item #155720, Pro Forma	\$314.29	
	Set-Up Charge	\$43.50	
	Freight	\$92.99	
	Two-Tone Duffel Bag-Screen, Item #6257-S.	\$2,079.30	
	Freight	\$213.81	
		\$12,198.38	CT 25056899
Adorama, Inc	SANDISK EXT MICROSDXC 256GB UHS-ICARD	\$130.50	
	DJI AIR 3 CASE	\$135.94	
	DJI MINI 4 PRO FLY MORE COMBO	\$1,195.16	
	DJI MINI 4 PRO FLY MORE COMBO	\$3,585.49	
	DJI MAVIC 3 PRO FLY MORE COMBO	\$2,731.82	
	DJI MAVIC 3 PRO FLY MORE COMBO	\$432.81	
		\$8,211.72	CT 25056900
Advantage ColorGraphics	Printing of 2025 Summer Fall Class Schedule	\$6,668.38	
	Printing of 2025 Summer Fall Class Schedule	\$1,600.00	
	Printing of 2025 Summer Fall Class Schedule	\$3,544.35	
	Sales tax on approx 1,550 campus copies	\$13.37	
	Periodical Mail Prep Simplified Saturation	\$567.25	
	Periodical Mail Prep Out-of-District Addressed	\$304.69	
	Delivery to Santa Maria Post Office and AHC	\$1,622.00	
		\$14,320.04	CT 25056901
AHC - Part-Time Faculty Association	Part-Time Faculty Reimbursement Per Article 11.7	\$1,879.79	
		\$1,879.79	CT 25056902
AHC Auxiliary Programs Corporation	General Fund Allocation to PCPA	\$501,553.15	

13-16

Allan Hancock College

Warrant Register

Check Dates from 5/1/2025 to 5/31/2025

Bank Code: CT

Vendor Name	Description	Amount	Warrant
		\$501,553.15	CT 25056903
AHC Foundation	FY 2024 -25 Foundation Adv Salary Reimbursement	\$8,195.83	
		\$8,195.83	CT 25056904
Amazon	Science Lab Supplies July 1, 2024-May 30, 2025	\$96.48	
	Science Lab Supplies July 1, 2024-May 30, 2025	\$133.71	
	INSTRUCTIONAL SUPPLIES 07-02-24 TO 05-30-25	\$31.53	
	INSTRUCTIONAL SUPPLIES 07-02-24 TO 05-30-25	\$69.59	
	LE INSTRUCTIONAL SUPPLIES: 07-02-24 TO 05-30-25	\$199.41	
	OFFICE/OPERATIONAL SUPPLIES, 7/01/24 - 5/31/25	\$145.33	
	OFFICE/OPERATIONAL SUPPLIES, 7/01/24 - 5/31/25	\$18.48	
	Instructional Supplies for Fire Academy,	\$234.89	
	Supplies JISSP workshops-activities,	\$59.79	
	Supplies JISSP workshops-activities,	\$59.80	
	Office Supplies: 07-01-24 to 05-30-25.	\$170.77	
	Operational supplies for maintenance - 2.6.2025 to	\$62.46	
	iFixIt Manta Kit	\$76.04	
	APC UPS Battery Replacement	\$171.47	
	Milwaukee Trilobe Set	\$57.63	
	FCD - 10M OS2 Fiber Cable	\$65.84	
	Instructional Supplies, 3/18/25 - 5/30/25	\$65.60	
	Dalema Waterproof Shelf Cover,600D Heavy Duty Dust	\$300.12	
	Office Supplies	\$130.50	
	Office Supplies	\$157.00	
	Art Instructional Supplies 4/10/2025-5/30/2025	\$76.96	
	Instructional supplies 4/11/2025-5/30/2025	\$170.60	
	Instructional supplies 4/11/2025-5/30/2025	\$955.35	
	Drama Instructional Supplies 4/14/2025-5/30/2025	\$350.22	
	OFFICE-OPERATIONAL SUPPLIES FOR LE,	\$194.51	
	OFFICE-OPERATIONAL SUPPLIES FOR LE,	\$228.87	
	Office Operational Supplies	\$82.79	
	Office Operational Supplies	\$468.90	
	DULFINE Leather Work Gloves, Small	\$198.51	
	3M Safety Glasses, ANSI Z87	\$111.31	
	DULFINE Leather Work Gloves, Medium	\$198.36	
	DULFINE Leather Work Gloves, Large	\$198.36	
	DULFINE Leather Work Gloves, X-Large	\$99.18	
	Milwaukee M18 Fuel Framing Nailer	\$772.10	
	Instructional Supplies for FSN,	\$36.84	
	Supplies for ITS: 3/24/25 - 5/30/25	\$93.50	
	Supplies for ITS: 3/24/25 - 5/30/25	\$105.05	
	Supplies for ITS: 3/24/25 - 5/30/25	\$192.16	
	Supplies for ITS: 3/24/25 - 5/30/25	\$23.29	
	Supplies for ITS: 3/24/25 - 5/30/25	\$54.36	
	Supplies for ITS: 3/24/25 - 5/30/25	\$56.13	
	Instructional supplies FSN	\$911.01	
	Office Supplies for 07-01-24 thru 05-30-25	\$120.68	
	Office Supplies for 07-01-24 thru 05-30-25	\$232.06	
	Instructional Supplies for Paramedic Academy,	\$36.84	
	Instructional Supplies for Paramedic Academy,	\$73.38	
	Operational Supplies for the Basic Needs Center	\$211.51	

Allan Hancock College

Warrant Register

Check Dates from 5/1/2025 to 5/31/2025

Bank Code: CT

Vendor Name	Description	Amount	Warrant
Amazon	Operational Supplies for the Basic Needs Center	\$436.67	
	Operational Supplies for the Basic Needs Center	\$70.09	
	Vet Tech Instructional Supplies: 1/29/25 - 5/30/25	\$64.41	
	Vet Tech Instructional Supplies: 1/29/25 - 5/30/25	\$90.61	
	Instructional Supplies for the Paramedic Academy,	\$77.97	
	Instructional Supplies for the Paramedic Academy,	\$73.38	
	Office Supplies, 3-11-25 to 5-30-25	\$55.49	
	BOOKS FOR LIBRARY, 3/25/25 - 5/30/25	(\$31.03)	
	BOOKS FOR LIBRARY, 3/25/25 - 5/30/25	\$118.54	
	BOOKS FOR LIBRARY, 3/25/25 - 5/30/25	\$701.04	
	Instructional Supplies, 3-28-25 to 5-30-25	(\$23.44)	
	Instructional Supplies, 3-28-25 to 5-30-25	\$42.48	
	Instructional Supplies, 3-28-25 to 5-30-25	\$473.77	
	Instructional Supplies, 7/01/24 - 5/30/25	\$25.26	
	Instructional Supplies, 7/01/24 - 5/30/25	\$62.50	
	Instructional Supplies Valid 4-8-2025 to 5-30-2025	\$391.86	
	Instructional Supplies Valid 4-8-2025 to 5-30-2025	\$46.11	
	Dance Instructional Supplies 4/10/2025-5/30/2025	\$1,387.74	
	Instructional supplies 4/11/2025-5/30/2025	\$640.52	
	Instructional supplies 4/11/2025-5/30/2025	\$37.09	
Office Supplies (3/11/25 to 5/30/25)	\$109.59		
Office Supplies 4.24.25 - 5.30.25	\$185.58		
	\$13,595.50		CT 25056905
Amazon Web Services, Inc	Amazon Web Services (AWS),	\$7,570.36	
		\$7,570.36	CT 25056906
American Business Machines	Wide Format Supplies, Staples	\$121.80	
	Staple Cartridge P1 (Corner-30 Sheets) - Booklet	\$81.56	
		\$203.36	CT 25056907
American Printing & Promotions	CORKSCREW BOTTLE OPENER, BROWN/SILVER, LASER	\$704.69	
	SET UP CHARGE - CORKSCREW BOTTLE OPENER	\$21.75	
	PROOF CHARGE - CORKSCREW BOTTLE OPENER	\$7.50	
	SHIPPING CHARGE - CORKSCREW BOTTLE OPENER	\$23.50	
	12 OZ. WINE TUMBLER - NAVY BLUE, WHITE IMPRINT AHC	\$408.90	
	SET UP CHARGE - WINE TUMBLER	\$40.79	
	PROOF CHARGE - WINE TUMBLER	\$7.50	
	SHIPPING CHARGE - WINE TUMBLER	\$77.50	
	PRO LOOP VEGAN LEATHER KEYCHAIN 3-15/16" X 9/16",	\$318.10	
	SET UP CHARGE - PRO LOOP VEGAN LEATHER KEYCHAIN	\$29.91	
	PROOF CHARGE - PRO LOOP VEGAN LEATHER KEYCHAIN	\$7.50	
	SHIPPING CHARGE - PRO LOOP VEGAN LEATHER KEYCHAIN	\$15.50	
	GRAPHIC DESIGN TYPE SETTING (ALL ITEMS)	\$17.50	
	\$1,680.64		CT 25056908
American Star Tours, Inc.	Bus Service for Cal Poly Road Trip, 4/12/2025.	\$1,620.00	

Allan Hancock College

Warrant Register

Check Dates from 5/1/2025 to 5/31/2025

Bank Code: CT

Vendor Name	Description	Amount	Warrant
		\$1,620.00	CT 25056909
Apple Inc.	10.9 inch iPad Wi-Fi 256GB-Silver	\$4,665.38	
	Recycle Fee	\$40.00	
	10.9 inch iPad Wi-Fi 256GB-Silver	\$31.00	
	16-inch MacBook Pro, Space Black,	\$3,478.91	
	3 Year AppleCare+ for Schools	\$279.00	
	Recycle Fee	\$5.00	
		\$8,499.29	CT 25056910
Art Central Art Supply	Instructional Supplies Art, 8/29/2024 - 5/30/2025	\$291.93	
		\$291.93	CT 25056911
B & B Steel & Supply	Instructional Supplies for Welding	\$5,411.14	
		\$5,411.14	CT 25056912
B&H Photo Video	Samsung 65 inch DU72000 Crystal UHD TV REG	\$430.65	
	LOGITECH C920s HD PRO WEBCAM REG	\$64.92	
	SANUS SYSTEMS ADVANCED TILT WALLMOUNT 6.8 INCHES	\$154.95	
	E Waste Fee	\$6.00	
	Shipping	\$203.40	
		\$859.92	CT 25056913
Benevolent & Protective Order Of The Elks #1538	Banquet Food	\$6,525.00	
		\$6,525.00	CT 25056914
Blue Robotics inc	WetLink Penetrator M10 - 5.5 mm HC	\$35.23	
	WetLink Penetrator M10 - 5.5mm LC	\$11.75	
	WetLink Penetrator M10 - 4.5mm LC	\$46.98	
	WetLink Bulkhead Wrench - M10	\$17.40	
	WetLink Penetrator Assembly Block	\$21.75	
	Potting Kit	\$10.88	
	Loctite Marine Epoxy	\$10.88	
	Pressure Relief Valve	\$32.63	
	Potted Cable Penetrator - M10	\$16.31	
	WetLink Penetrator Blank - No Hole	\$52.20	
	Basic ESC	\$82.65	
	Shipping	\$15.25	
		\$353.91	CT 25056915
Boldyn Networks Higher Ed LLC	AWS Cloud Migration Consulting & Support Services	\$5,162.25	
		\$5,162.25	CT 25056916
Boone Printing & Graphics, Inc	Student Academic Planner: - 122 pages (118 pages +	\$15,047.91	
		\$15,047.91	CT 25056917
Bremer Auto Parts	Supplies/parts for LE vehicles: 7/02/24 - 5/30/25.	\$6.95	
	Supplies/parts for LE vehicles: 7/02/24 - 5/30/25.	\$40.23	
	Supplies/parts for LE vehicles: 7/02/24 - 5/30/25.	\$69.06	
		\$116.24	CT 25056918
Cal State Auto Parts	Oil per Invoice 329301	\$94.98	

13-19
Allan Hancock College
Warrant Register
Check Dates from 5/1/2025 to 5/31/2025
Bank Code: CT

Vendor Name	Description	Amount	Warrant
Cal State Auto Parts	Oil Filter per Invoice 329292	\$34.64	
	Oil Filter per Invoice 329306	\$6.21	
	Oil per Invoice 329521	\$94.98	
	Oil per Invoice 329665	\$97.61	
		\$328.42	CT 25056919
CalSoft Water	Reverse Osmosis for Buildings: J,K,M,N,CBC,S2,R2	\$55.90	
	Reverse Osmosis for Buildings: J,K,M,N,CBC,S2,R2	\$128.95	
		\$184.85	CT 25056920
Camarenas Tire	Tires LE Vehicles 2-27-25 to 5-30-25	\$2,434.04	
		\$2,434.04	CT 25056921
Carolina Biological	Carbon Dioxide Water Test Kit	\$62.10	
	Freight and Handling	\$17.43	
		\$79.53	CT 25056922
Carr's Boot Shop	Safety boots for employees 4-1-25 to 6-30-25	\$166.38	
	Safety boots for employees 4-1-25 to 6-30-25	\$215.31	
		\$381.69	CT 25056923
CDW Government Inc	Dell Latitude 5450 Laptop	\$2,382.69	
	Brother Workhorse MFC Multifunction Color Printer	\$494.80	
	Recycling Fee	\$8.00	
	StarTech HDMI over IP - CDW Part #: 5403839	\$4,700.94	
	APC RBC57 Replacement Battery Cartridge, CDW Part	\$1,449.07	
	Dell Latitude 5450 - Quote: 1CGZCNT	\$3,335.01	
	Dell Latitude 5450 - Quote: 1CGZCNT	\$38,041.32	
	Dell WD196 Docking Station	\$6,325.66	
	Recycling Fee	\$120.00	
	Dell OptiPlex 7020 - CDW Part #: 7852454	\$15,966.68	
	Dell Monitor - 24	\$3,789.07	
	Dell Latitude 5450	\$20,640.37	
	Dell WD19S Docking Station	\$3,584.54	
	Recycling Fee 15-35"	\$100.00	
Recycling Fee 4-15"	\$68.00		
		\$101,006.15	CT 25056924
Coast Diesel Service	Parts for Truck Driving Program	\$140.00	
	Labor for Truck Driving Program,	\$184.00	
	Labor for Truck Driving Program,	\$444.00	
		\$768.00	CT 25056925
Community College League Of California	Springshare CY Library Database: 1/01/25-12/31/25.	\$1,485.00	
		\$1,485.00	CT 25056926
Consolidated Electrical Distributor	Ballast,SYL LEDRV55UNVL1300DIM1A	\$374.70	
	Rab Slim 15 Wallpack per Invoice 7839-1020434	\$81.56	
		\$456.26	CT 25056927
Culligan Of Lompoc	Monthly rental for 7 mixed bed ID tanks	\$35.24	

13-20
Allan Hancock College
Warrant Register
Check Dates from 5/1/2025 to 5/31/2025
Bank Code: CT

Vendor Name	Description	Amount	Warrant
		\$35.24	CT 25056928
Culligan/Central Coast Water Treatment	CAMPUS GRAPHICS DRINKING WATER DELIVERY	\$20.25	
	FUEL SURCHARGE	\$4.20	
	HOT COLD WATER STAND RENTAL	\$11.00	
		\$35.45	CT 25056929
	Deionized Water for Bldg M	\$100.00	
		\$100.00	CT 25056930
	Bottled Water Delivery Service 7-1-24 thru 6-30-25	\$32.20	
		\$32.20	CT 25056931
Custom Colors Auto Body Supplies, Inc.	LV B/C REDUCER MED, Item #LUM LV375G. Invoice #	\$31.54	
	Acetone 5GL, Item #SLV 200-5. Invoice #101LJ3411.	\$97.82	
		\$129.36	CT 25056932
Victor DeAlba	Independent contractor agreement to provide	\$5,100.00	
	Independent contractor agreement to provide	\$4,250.00	
		\$9,350.00	CT 25056933
Desert Diamond Industries LLC	Fire Rescue Safety 14" Blade	\$1,632.00	
	Ground Shipping	\$40.00	
		\$1,672.00	CT 25056934
Design Source USA, Inc	Graduation Sash	\$9,876.46	
	Shipping charges	\$105.00	
		\$9,981.46	CT 25056935
Downs Government Affairs, LLC	Services for consortium project 7/1/2024-6/30/2025	\$2,000.00	
		\$2,000.00	CT 25056936
William Drake	Reimbursement For Office Supplies	\$16.30	
		\$16.30	CT 25056937
EKC Enterprises Inc	Audio Visual Support Services for On-site Labor,	\$3,750.02	
	Audio Visual Support Services for On-site Labor,	\$1,249.98	
		\$5,000.00	CT 25056938
Evident Scientific Inc	CX23 Upright Microscope	\$31,502.04	
	Shipping	\$650.00	
		\$32,152.04	CT 25056939
Eyemed Vision Care	vision premiums for may 2025 Retirees and COBRA	\$724.13	
	vision insurance premiums may 2025 active employees	\$4,309.57	
		\$5,033.70	CT 25056940
Facilities Planning And Consulting Services	Facilities Related Consulting Services for Fiscal	\$6,800.00	
	Consulting and Planning Services for the Partial	\$8,000.00	
		\$14,800.00	CT 25056941
Farm Supply Company	Instructional Supplies, 9/05/24 to 5/30/25	\$79.72	

13-21
Allan Hancock College
Warrant Register
Check Dates from 5/1/2025 to 5/31/2025
Bank Code: CT

Vendor Name	Description	Amount	Warrant
		\$79.72	CT 25056942
Federal Express Corp	Mailings for Acct #1104-8488	\$9.13	
		\$9.13	CT 25056943
Ferguson Enterprises Inc	Drain Opener per Invoice 5881412	\$29.97	
	Supplies per Invoice 5885278	\$53.55	
	Urinal Drain Cleaner per Invoice 5888688	\$43.48	
	Supplies per Invoice 5895250	\$113.08	
	Faucet, Item PFX4085 per Invoice 5895243	\$254.88	
	Supplies per Invoice 5901089	\$368.88	
	Freight Charges	\$19.58	
	M12 Wtr Pump Bare Tool per Invoice 5936647	\$216.41	
	Supplies per Invoice 5883070	\$91.57	
	Override Button Assy, EBV - 130 W/Scrw	\$146.78	
	Freight Charges	\$13.05	
	Deck Mounted Sensor, Per Inv. 5896313	\$354.00	
	Freight Charges	\$13.05	
		\$1,718.28	CT 25056944
Fisher Scientific Co Llc	Chemistry Lab Supplies: 7/01/24 - 5/30/25	\$12.72	
	Science Lab Supplies July 1, 2024-May 30, 2025	\$1,199.07	
	Supplies for Organic Chemistry Labs, per	\$98.97	
		\$1,310.76	CT 25056945
Follett Heg - Ahc Bookstore	Textbook gift cards- \$100 Value. Quote dated	\$3,000.00	
	Textbook gift cards- \$50 value	\$1,000.00	
	Textbook gift cards- \$25.00 value	\$1,000.00	
		\$5,000.00	CT 25056946
Foodbank Of Santa Barbara County	Food for Foodshare and Basic Needs Food Pantry for	\$1,453.66	
		\$1,453.66	CT 25056947
	Food for Foodshare and Basic Needs Food Pantry for	\$491.88	
		\$491.88	CT 25056948
Franchise Tax Board	Payroll Deduction 05.09.2025	\$478.42	
		\$478.42	CT 25056949
Amy Gisclon	Reimbursement for supplies and postage for the	\$12.31	
	Reimbursement for supplies and postage for the	\$20.75	
		\$33.06	CT 25056950
GotSafety, LLC	Annual Technology Package - Diamond: 7/01/24 -	\$1,160.00	
		\$1,160.00	CT 25056951
Grainger Inc.	Ceiling Tile, 48x24, Pk10 per Invoice 9430596586	\$694.56	
	Cord Reel, 30 ft. per Invoice 9477048376	\$710.61	
		\$1,405.17	CT 25056952
Henry Schein Inc	Generation 2 Wagon 8 Station,	\$3,806.13	
	Tape Zinc-Oxide M Tape, Item Code #3648036.	\$282.14	
	M Wrap Navy, Item Code #3640173.	\$118.65	

13-22

Allan Hancock College

Warrant Register

Check Dates from 5/1/2025 to 5/31/2025

Bank Code: CT

Vendor Name	Description	Amount	Warrant
		\$4,206.92	CT 25056953
Lee Herrick	Poetry Reading for National Poetry Month Event on	\$1,000.00	
		\$1,000.00	CT 25056954
Home Depot	Instructional Supplies for Fire Academy	\$61.10	
		\$61.10	CT 25056955
J B Dewar	Fuel for AHC Community Ed. Truck Driving Class,	\$3,929.10	
		\$3,929.10	CT 25056956
Jj Keller And Associates Inc	J.J. Keller Entry-Level Driver Training- Obtaining Shipping and Handling	\$1,657.35 \$295.22	
		\$1,952.57	CT 25056957
Jorgenson Industrial Companies	Gladiator Wood Lockers, Open, 30"Wx20"Dx77"H, Freight Charge	\$52,685.30 \$6,200.00	
		\$58,885.30	CT 25056958
Kaplan Early Learning Co	Supplies for Children's Center per quote #545780 Supplies for Children's Center per quote #545780 Supplies for Children's Center per quote #545780	\$842.06 \$1,396.92 \$2,934.98	
		\$5,173.96	CT 25056959
Kenco Construction Services, Inc	One Onsite DSA Project Inspector for the	\$7,040.00	
		\$7,040.00	CT 25056960
Kennedy Family Counseling LLC	Professional Service Agreement to provide two (2-	\$1,100.00	
		\$1,100.00	CT 25056961
Knuth Machine Tools Usa Inc	Travel and Labor for Shear Repair	\$4,521.00	
		\$4,521.00	CT 25056962
Matthew Koenig	STALE DATED PAYROLL WRNT RFC3.17.25	\$240.03	
		\$240.03	CT 25056963
Lakeshore Learning Materials LLC	Operational Supplies for Children's Center per Operational Supplies for Children's Center per	\$4,562.89 \$2,445.08	
		\$7,007.97	CT 25056964
Liebert Cassidy Whitmore	Professional Legal Services: 7/01/24 - 6/28/25 Professional Legal Services: 7/01/24 - 6/28/25 Professional Legal Services: 7/01/24 - 6/28/25	\$1,305.00 \$290.00 \$328.00	
		\$1,923.00	CT 25056965
Linde Gas & Equipment Inc.	Supplies for the Chem Labs 11-20-24 thru 05-30-25. Supplies for the Chem Labs 11-20-24 thru 05-30-25. Supplies for the Chem Labs 11-20-24 thru 05-30-25. Science Lab Supplies October 30, 2024-May 30, 2025 Science Lab Supplies October 30, 2024-May 30, 2025 Supplies for the Chem Labs 11-20-24 thru 05-30-25.	\$46.04 \$46.04 \$69.06 \$123.03 \$25.87 \$46.04	

13-23

Allan Hancock College

Warrant Register

Check Dates from 5/1/2025 to 5/31/2025

Bank Code: CT

Vendor Name	Description	Amount	Warrant
		\$356.08	CT 25056966
Lowes	ART Instructional Supplies 11/4/2024-5/30/2025	\$265.47	
		\$265.47	CT 25056967
McDougal Boehmer Foley Lyon Mitchell	Professional Legal Services thru 03-31-25. Invoice	\$145.00	
		\$145.00	CT 25056968
Mission Linen Supply	Laundry Services for Automotive Collision Repair:	\$22.25	
	Laundry Services for Automotive Technology Program	\$34.60	
	Kitchen linen service for Culinary Arts,	\$47.70	
		\$104.55	CT 25056969
Mountain Mike's Pizza	Food Purchase for CTE Career Academy	\$200.97	
		\$200.97	CT 25056970
ODP Business Solutions LLC	Office Operational Supplies for FSN,	\$100.91	
	Basic Needs Center Supplies, 7/01/2024 - 5/30/2025	\$489.78	
		\$590.69	CT 25056971
Old Town Shirt Factory	Sport Tek Women's Colorblock Hooded Raglan Jacket,	\$37.79	
		\$37.79	CT 25056972
PARS Public Agency Retirement	PAYROLL DEDUCTION 05//09/2025	\$11,407.36	
		\$11,407.36	CT 25056973
Part Time Faculty AHC - Member	PAYROLL DEDUCTION 05//09/2025	\$128.94	
		\$128.94	CT 25056974
Pasco Scientific	Basic Optics Light Source, Item #OS-8470, Quote #	\$913.50	
	Shipping	\$22.84	
		\$936.34	CT 25056975
PCPA	FastTrak Toll Charge 3/23/25 Invoice #	\$8.00	
		\$8.00	CT 25056976
Pocket Nurse Enterprises LLC	Clinical Chloe Patient Care Simulator	\$1,517.06	
	Shipping	\$21.76	
	Tongue Depressor	\$8.45	
	Filter Straw 5 micron	\$227.07	
	Demo Dose Ampule Clear 1 ml	\$29.88	
	Vacutainer Blood Collect 10ml Red Glass Serum	\$172.91	
	Vacutainer Hemogard 4ml Red Plastic Serum	\$87.39	
	Probe Cover	\$18.21	
	Demo Dose Nitr Ointment 30gm	\$28.85	
	Demo Dose Nitr Oint Application Paper	\$3.03	
	Demo Dose Nitro Derm Patch .2mg	\$13.09	
	Demo Dose Nitro Derm Patch .3mg	\$13.25	
	Tape Paper Surgical	\$9.50	
	Bandage Sheer Spot 7/8 IN	\$11.75	
	Demo Insulin Bundle	\$11.87	
	Demo Dose Ear Drop 10ml	\$33.23	

13-24

Allan Hancock College

Warrant Register

Check Dates from 5/1/2025 to 5/31/2025

Bank Code: CT

Vendor Name	Description	Amount	Warrant
Pocket Nurse Enterprises LLC	Basin Ear Goldnamer	\$41.78	
	Compressor Nebulizer	\$36.09	
	Jelly Lube Tube	\$51.11	
	Demo Dose Albumn Humn 25g 100ml	\$15.19	
	Body Fat Monitor Hand Held	\$76.02	
	Artificial Urine Set of 4	\$114.02	
	Shipping & Handling	\$21.75	
		\$2,563.26	CT 25056977
Point Of Action	Port Authority Core	\$223.45	
	Port Authority Womens Core Soft Shell	\$62.39	
	Nike Therma FIT Pocket Full Zip	\$194.43	
	Port Authority Womens Core Soft Shell	\$163.88	
	Port Core Soft Shell Jacket	\$163.88	
	Port Authority Core Soft Shell Jacket	\$113.60	
	Setup	\$24.99	
	Embroidery: AHC College Corps Grad Sashes 2025 per	\$126.00	
	Embroidery: AHC College Corps Grad Sashes 2025 per	\$49.00	
	Setup	\$10.80	
Setup	\$4.20		
		\$1,136.62	CT 25056978
Postmaster	Periodical Mailing of Class Schedules	\$5,000.00	
		\$5,000.00	CT 25056979
Premier Water Management, LLC	Monthly Water Treatment, Santa Maria Campus	\$197.90	
	Monthly Water Treatment, Lompoc Campus	\$246.20	
		\$444.10	CT 25056980
ProCare Janitorial Supply, Inc.	Sensor XP 12" Vacuum	\$770.03	
	Go Free Flex Pro II Vacuum, 12AH	\$3,381.32	
	Sensor XP 18" Vacuum	\$974.79	
	Admiral X Brc 40-34 Carpet Extractor	\$4,351.70	
	Custodial Supplies, 10/01/2024 thru 5/30/2025	\$57.99	
	Custodial Supplies, 10/01/2024 thru 5/30/2025	\$14.25	
	Go Free Flex Pro IT Vacuum w/Xover Kit	\$3,381.32	
	Supplies per Invoice 181905	\$3,613.78	
	Safehand Nitrile Glove per Invoice 181905-1	\$85.46	
	Falcon Waterfree Urinal Cart per Invoice 181905-2	\$594.00	
		\$17,224.64	CT 25056981
Proquest Llc	BOOKS FOR LIBRARY	\$75.44	
	BOOKS FOR LIBRARY	\$146.58	
	BOOKS FOR LIBRARY: 3/18/25 - 5/30/25	\$496.71	
		\$718.73	CT 25056982
Rays Auto Parts	Parts per Invoice 666266	\$65.57	
	CA EVC Charge per Invoice #666266	\$2.00	
	Sta-Bil Fuel Stabilizer per Invoice 665156	\$9.78	
	Oil, HD30 per Invoice 665133	\$20.52	
	RTU EXT/Life, AntiFreeze Coolant per Inv 665409	\$94.55	
	Blade per Invoice 665688	\$10.54	

13-25
Allan Hancock College
Warrant Register
Check Dates from 5/1/2025 to 5/31/2025
Bank Code: CT

Vendor Name	Description	Amount	Warrant
Rays Auto Parts	Supplies per Invoice 665689	\$24.45	
	Brake Fluid per Invoice 666921	\$31.53	
	Truetimber 2PC Floormat per Invoice 666727	\$40.23	
	Sway Bar Bushing per Invoice 667058	\$22.37	
	Spark Plug per Invoice 666544	\$5.85	
		\$327.39	CT 25056983
Gregory Riley	Provide accompaniment services for voice and	\$1,500.00	
		\$1,500.00	CT 25056984
Samy's Camera	Canon 5D Mark IV Digital SLR Camera Body	\$1,870.15	
	Nikon D850 Digital SLR Camera Body	\$2,606.68	
	Phototools DSLR Medium Camera Case	\$27.03	
	Promaster LP-E6NH Lithium-Ion Replacement Battery	\$30.59	
	SanDisk 128GB Extreme Memory Card	\$40.67	
	Phototools DSLR Medium Camera Case	\$27.03	
	Canon EF 100mm Macro USM Lens	\$1,242.09	
	Hoya 67mm NXT Plus UV Filter	\$24.48	
	Nikon EN-EL15c Rechargeable Lithium-Ion Battery	\$98.57	
	Sigma 70-200mm DG OS HSM Sports Lens for Nikon F	\$1,267.65	
	Hoya 82mm NXT Plus UV Filter	\$42.13	
		\$7,277.07	CT 25056985
Santa Barbara Co Dept Of Social Svc	WRC Lease Operating Costs 3-1-25 to 6-30-25	\$2,203.63	
		\$2,203.63	CT 25056986
Santa Barbara County Action Network	INSPIRING LEADERSHIP AWARDS 2025 SPONSORSHIP	\$1,000.00	
		\$1,000.00	CT 25056987
Santa Maria Times	Monthly Online Big Ad July 2024-June 2025	\$1,000.00	
	Quarter-page Ad Summer Fall Registration	\$380.00	
	Digital Reveal Ad 2025 Summer Fall Registration	\$350.00	
		\$1,730.00	CT 25056988
Save Mart Supermarkets	Food Supplies for Children's Center,	\$435.96	
	Food Supplies for Children's Center,	\$271.64	
		\$707.60	CT 25056989
Scoreboard Media LLC	Scoreboard Advertising at St. Josephs High School	\$3,000.00	
		\$3,000.00	CT 25056990
Ian Shafer	Piano tuning services 3/10/25-6/30/25	\$300.00	
		\$300.00	CT 25056991
Sherwin-Williams	Supplies per Invoice 4186-1	\$80.75	
		\$80.75	CT 25056992
Signs Of Success Inc	1/8" Aluminum Composite Panel w/ digital print,	\$682.87	
	Set Up	\$59.81	
	Labor	\$50.00	
		\$792.68	CT 25056993
SISC III	INSURANCE PREMIUMS MAY 2025	\$583,653.00	

13-26

Allan Hancock College

Warrant Register

Check Dates from 5/1/2025 to 5/31/2025

Bank Code: CT

Vendor Name	Description	Amount	Warrant
		\$583,653.00	CT 25056994
Skills Usa California	Regional Conference Substitution Fee	\$50.00	
		\$50.00	CT 25056995
Smart & Final	Food for Non-credit HOEC Classes: 2/05/25 to	\$60.03	
	Food/Drink Supplies for MESA/STEM Events: 3/18/25	\$355.88	
	Bulldog Bites 11.14.24 - 6.30.25	\$812.26	
	Snacks and Food Supplies for UTC Workshops and	\$77.65	
	Food and Beverage Purchases for Men's Support	\$368.30	
	Food and Beverage Purchases for Men's Support	\$76.78	
	Food for various outreach events and activities.	\$224.85	
	Supplies for Biology Labs: 07-05-24 thru 05-30-25	\$28.17	
	Food for Student Lunch Locker- Santa Maria,	\$44.14	
	Food for Student Lunch Locker- Santa Maria,	\$414.29	
	Food for Student Lunch Locker- Santa Maria,	\$580.63	
	Food for Non-credit HOEC Classes: 2/05/25 to	\$67.68	
	Food and Beverage Purchases for Men's Support	\$106.81	
	Food and Beverage Purchases for Men's Support	\$799.38	
		\$4,016.85	CT 25056996
	Food for Children's Center 5-01-25 to 6-30-25	\$310.35	
	Food for Children's Center 5-01-25 to 6-30-25	\$142.33	
	Food for Children's Center 5-01-25 to 6-30-25	\$128.70	
	Food for Children's Center 5-01-25 to 6-30-25	\$330.35	
	Food for Children's Center 5-01-25 to 6-30-25	\$202.80	
	Food for Children's Center 11-1-24 to 6-30-25	\$170.92	
	Food for Children's Center 11-1-24 to 6-30-25	\$254.37	
		\$1,539.82	CT 25056997
	Food for Culinary Arts, 3-28-25 to 6-28-25	\$128.56	
	Food for Culinary Arts, 3-28-25 to 6-28-25	\$267.87	
	Food for Culinary Arts, 3-28-25 to 6-28-25	\$582.52	
	Food for Culinary Arts, 3-28-25 to 6-28-25	\$97.70	
	Food for Culinary Arts, 3-28-25 to 6-28-25	\$85.20	
	Food for Culinary Arts, 3-28-25 to 6-28-25	\$437.47	
		\$1,599.32	CT 25056998
Snap-On Industrial	Basic Multimeter Daylight CERT	\$5,686.54	
	Max Fuse Buddy Kit	\$729.66	
	Clamp-On Meter with App	\$2,295.17	
	55" 10-Drawer Double Bank Royal Blue Roll Cab	\$4,538.96	
	Power Probe 3 with Lead Set	\$567.24	
	Pro Relay Buddy Test Kit	\$352.35	
	Clamp-On Amp Probe	\$316.53	
	OBD-11 Breakout Box	\$394.63	
	15 Ft. Retractable Test Lead Kit	\$349.40	
		\$15,230.48	CT 25056999
Specialty Constructors Services Inc	Speciality Constructors, Inc. shall furnish all	\$25,752.60	
		\$25,752.60	CT 25057000

Allan Hancock College

Warrant Register

Check Dates from 5/1/2025 to 5/31/2025

Bank Code: CT

Vendor Name	Description	Amount	Warrant
The Lincoln Electric Company	Instructional Supplies,	\$886.43	
		\$886.43	CT 25057001
Uline Inc	Heavy Duty Corrugated Boxes , S-4876	\$56.55	
	Corrugated Boxes, S-4888	\$86.46	
	Corrugated Boxes, Double Wall, S-15041	\$241.43	
	Shipping Charges	\$91.45	
		\$475.89	CT 25057002
United Parcel Service	UPS Charges, 7-1-24 thru 6-30-25, Account	\$570.46	
	UPS Charges, 7-1-24 thru 6-30-25, Account	\$82.95	
		\$653.41	CT 25057003
US Bank Corporate Payment System	Apr 25, 2025 US BANK STMT	\$54,707.30	
		\$54,707.30	CT 25057004
Virtual Vri	TypeWell Transcribing: Remote transcribing for	\$390.00	
		\$390.00	CT 25057005
Vital Records Control	Shredding Service for Counseling Office Account #	\$105.66	
	Confidential Records Shredding 7-1-24 - 6-30-25	\$105.66	
		\$211.32	CT 25057006
Ward's Science Inc	Science Lab Supplies July 1, 2024-May 30, 2025	\$41.19	
		\$41.19	CT 25057007
Western Propane Service	Instructional Supplies Non-Credit Jewelry Class	\$18.34	
		\$18.34	CT 25057008
Yankee Book Peddler Inc	BOOKS FOR LIBRARY, 3/18/25 - 5/30/25	\$1,304.66	
		\$1,304.66	CT 25057009
Angelica Anaya	Manual Refund Submitted	\$150.00	
		\$150.00	CT 25057010
Takara Aquino	Manual Refund Submitted	\$1,849.00	
		\$1,849.00	CT 25057011
Lizzette Carlos	Manual Refund Submitted	\$178.00	
		\$178.00	CT 25057012
Jaime Carroll	Manual Refund Submitted	\$1,739.54	
		\$1,739.54	CT 25057013
Casilda Chavez	Manual Refund Submitted	\$150.00	
		\$150.00	CT 25057014
Adrian Cruz	Manual Refund Submitted	\$164.00	
		\$164.00	CT 25057015
Talia Diaz	Manual Refund Submitted	\$525.00	
		\$525.00	CT 25057016
David Garcia	Manual Refund Submitted	\$1,780.00	
		\$1,780.00	CT 25057017

13-28

Allan Hancock College

Warrant Register

Check Dates from 5/1/2025 to 5/31/2025

Bank Code: CT

Vendor Name	Description	Amount	Warrant
Rocio Garcia	Manual Refund Submitted	\$1,252.00	
		\$1,252.00	CT 25057018
Maribel Guevara Ortiz	Manual Refund Submitted	\$164.00	
		\$164.00	CT 25057019
Cassius Hope	Manual Refund Submitted	\$1,701.00	
		\$1,701.00	CT 25057020
Jaquelin Izquierdo	Manual Refund Submitted	\$164.00	
		\$164.00	CT 25057021
Basilia Lopez	Manual Refund Submitted	\$164.00	
		\$164.00	CT 25057022
Jessica Martinez Garcia	Manual Refund Submitted	\$150.00	
		\$150.00	CT 25057023
Guadalupe Narez	Manual Refund Submitted	\$500.00	
		\$500.00	CT 25057024
Benny Nicolas	Manual Refund Submitted	\$142.00	
		\$142.00	CT 25057025
Remelyn Perez	Manual Refund Submitted	\$435.00	
		\$435.00	CT 25057026
Miguel Sanchez	Manual Refund Submitted	\$164.00	
		\$164.00	CT 25057027
Ayerin Torres	Manual Refund Submitted	\$150.00	
		\$150.00	CT 25057028
Yesenia Villa-Munoz	Manual Refund Submitted	\$1,188.00	
		\$1,188.00	CT 25057029
Braulio Angeles	Open Mileage 4.2-30.25	\$23.94	
		\$23.94	CT 25057030
Valerie Avelino	Open Mileage 4.2-30.25	\$78.68	
		\$78.68	CT 25057031
Barrett, Robert	INTERVIEW REIMBURSEMENT 5.2025	\$300.00	
		\$300.00	CT 25057032
Gregory Byard	CCACA Conf. Davis, CA	\$89.68	
		\$89.68	CT 25057033
Ricardo Cano	Open Mileage 4.30.25	\$0.00	
	Open Mileage 4.30.25	\$35.28	
		\$35.28	CT 25057034
Cccsaa	1003 YVONNE TENIENTE Reg 6.24-28.25	\$500.00	
		\$500.00	CT 25057035
	PDCONF REG 6.25-6.27 ROBB,STEPHANIE	\$500.00	

13-29
Allan Hancock College
Warrant Register
Check Dates from 5/1/2025 to 5/31/2025
Bank Code: CT

Vendor Name	Description	Amount	Warrant
		\$500.00	CT 25057036
City of Lompoc	Sanitary Landfill Fees 7.1.2024 - 6.30.2025.	\$141.05	
		\$141.05	CT 25057037
James Colon	Open Mileage 4.3-20.25	\$119.70	
		\$119.70	CT 25057038
Columbia Business Center Partners Lp	Lease of 890 E Stowell: Base Rent Lease	\$26,190.00	
		\$26,190.00	CT 25057039
Comcast Cable	Comcast Monthly Internet Costs: 7/01/24 - 6/30/25	\$231.08	
		\$231.08	CT 25057040
	Comcast Monthly Internet Costs: 7/01/24 - 6/30/25	\$185.08	
		\$185.08	CT 25057041
Constellation Newenergy Inc	Electricity Services 7.1.2024 - 6.30.2025	\$37,651.35	
	Electricity Services 7.1.2024 - 6.30.2025	\$6,644.35	
		\$44,295.70	CT 25057042
	Electricity Services 7.1.2024 - 6.30.2025	\$0.15	
	Electricity Services 7.1.2024 - 6.30.2025	\$0.03	
		\$0.18	CT 25057043
	Electricity Services 7.1.2024 - 6.30.2025	\$34.04	
	Electricity Services 7.1.2024 - 6.30.2025	\$6.01	
		\$40.05	CT 25057044
David Degroot	ASCCC Spring Plenary Irvine, CA	\$1,860.64	
		\$1,860.64	CT 25057045
Erik Diggs	Open Mileage 4.7-30.25	\$182.00	
		\$182.00	CT 25057046
Doaa Elkhatib	Open Mileage 4.1-30.25	\$16.94	
		\$16.94	CT 25057047
Enterprise Rent-A-Car	Hodges, Edwin CalWORKS Sacramento, CA 4.27-5.02.25	\$313.46	
		\$313.46	CT 25057048
FasTrak	I712531784416 LIC PLATE CA 1578858 Byard 4.25-26.2	\$8.00	
		\$8.00	CT 25057049
Hilton Garden Inn Santa Barbara/Goleta	Lodging 5.24.25 Allebe, Adrienne	\$1,332.66	
		\$1,332.66	CT 25057050
Theresa Kings	PREPAY MEALS 5.29-31.25	\$2,580.00	
		\$2,580.00	CT 25057051
Lara, Karina	INTERVIEW REIMBURSEMENT4.30-5.02.25	\$329.19	
		\$329.19	CT 25057052
Monica Lopez Flores	Open Mileage 4.10-30.25	\$163.24	

13-30
Allan Hancock College
Warrant Register
Check Dates from 5/1/2025 to 5/31/2025
Bank Code: CT

Vendor Name	Description	Amount	Warrant
		\$163.24	CT 25057053
Emily Lopez-Ybarra	Open Mileage 1.21-5.06.25	\$2,093.00	
		\$2,093.00	CT 25057054
Virginia Martinez Najera	Open Mileage 4.2-30.25	\$107.80	
		\$107.80	CT 25057055
Priscilla Morales	Open Mileage 4.1-30.25	\$151.06	
		\$151.06	CT 25057056
Krystle Navarrette	Open Mileage 2.28-5.01.25	\$46.90	
		\$46.90	CT 25057057
Pacific Gas & Electric Company	Electricity Services 7.1.2024- 6.30.2025	\$45.65	
	Electricity Services 7/1/2024 - 6/30/2025	\$12.13	
		\$57.78	CT 25057058
	Electricity Services 7.1.2024- 6.30.2025	\$79.80	
	Electricity Services 7/1/2024 - 6/30/2025	\$21.21	
		\$101.01	CT 25057059
	Electricity Services 7.1.2024- 6.30.2025	\$18.86	
	Electricity Services 7/1/2024 - 6/30/2025	\$5.01	
		\$23.87	CT 25057060
	Electricity Services 7.1.2024- 6.30.2025	\$3,500.46	
	Electricity Services 7/1/2024 - 6/30/2025	\$930.50	
		\$4,430.96	CT 25057061
	Electricity Services 7.1.2024- 6.30.2025	\$533.21	
	Electricity Services 7/1/2024 - 6/30/2025	\$141.74	
		\$674.95	CT 25057062
Palm Springs Hilton	CONF #3244263345 5.29-31.25 KINGS	\$2,198.26	
		\$2,198.26	CT 25057063
Diana Perez	Open Mileage 4.28.25	\$105.70	
		\$105.70	CT 25057064
Alberto Restrepo	ASCCC Spring Plenary Irvine, CA	\$1,892.47	
		\$1,892.47	CT 25057065
Victor Rodriguez	Open Mileage 4.8-9.25	\$33.88	
	Open Mileage 4.30.25	\$19.74	
		\$53.62	CT 25057066
Justin Rucker	Skills USA Ontario, CA	\$116.70	
		\$116.70	CT 25057067
Melissa Rudder	Open Mileage 2.25, 4.25	\$70.00	
		\$70.00	CT 25057068
Genevieve Siwabessy	CSSO Spring 2025 Sym San Francisco, CS	\$701.74	
		\$701.74	CT 25057069

Allan Hancock College

Warrant Register

Check Dates from 5/1/2025 to 5/31/2025

Bank Code: CT

Vendor Name	Description	Amount	Warrant
Kristy Soriano	Open Mileage 4.4-25.25	\$15.12	
		\$15.12	CT 25057070
The Hadsten Solvang	Lodging Balance 6.4-6.25 Walthers, Kevin	\$12,200.28	
		\$12,200.28	CT 25057071
David Vasquez	CACCRAO Conf San Diego, CA	\$1,254.11	
		\$1,254.11	CT 25057072
Virginia Velati Tirona	ZTC Summit Valencia, CA	\$170.10	
		\$170.10	CT 25057073
Verizon Select Svc Inc	Long Distance and Toll Free Service Charges	\$10.39	
		\$10.39	CT 25057074
Jeremy Wirth	Open Mileage 4.25,30.25	\$70.56	
		\$70.56	CT 25057075
4imprint Inc.	Cotton Grocery Tote, Color: Natural / Royal Blue, Set-up Charge	\$769.95	
	Freight	\$59.81	
		\$98.92	
		\$928.68	CT 25057076
Sonia Aguirre	Reimbursement for supplies for floral design	\$443.71	
	Reimbursements for supplies for floral design	\$398.63	
		\$842.34	CT 25057077
Akeso Occupational Health	TB, X-ray, Medical Physicals: 7-01-24 to 6-30-25	\$265.00	
		\$265.00	CT 25057078
Amazon	Instructional Supplies for the Paramedic Academy, FASN Instructional Supplies LVC, LVC Library Books 4.1.25 - 5.30.25	\$179.38 (\$55.15) \$207.00	
	Supplies for Automotive Tech Program: 4/10/25 - Instructional supplies 4/11/2025-5/30/2025	\$505.49 \$68.69	
	LVC LRC Lola Dority book funds 4.16.25 - 5.30.25	\$188.78	
	Office Supplies 4.24.25 - 5.30.25	\$68.93	
	Vet Tech Instructional Supplies: 1/29/25 - 5/30/25	(\$41.31)	
	Office Supplies	\$95.64	
	Office Supplies	\$467.96	
	Instructional Supplies ABS, 4/11/25 - 5/30/25	\$22.14	
	Instructional Supplies ABS, 4/11/25 - 5/30/25	\$29.23	
	Instructional Supplies ABS, 4/11/25 - 5/30/25	\$103.77	
	Office Operational Supplies ABS, 4/11/25 - 5/30/25	\$0.62	
	Chemistry Lab Supplies: 7/01/24 - 5/30/25	\$207.12	
	Commencement Supplies per Invoice #16VJ-3QVP-V9XR.	\$97.37	
	Operational Supplies - Grounds, 10/02/24 - 5/30/25	\$93.45	
	Operational Supplies - Facilities,	\$23.02	
	Operational supplies for maintenance - 2.6.2025 to	\$36.63	
	Operational supplies for maintenance - 2.6.2025 to	\$79.75	
	Operational supplies for maintenance - 2.6.2025 to	\$325.13	
	Instructional supplies 4/11/2025-5/30/2025	\$80.46	
	Instructional Supplies for the Paramedic Academy,	\$26.96	
	Office/Operational Supplies, 4/22/25 - 5/30/25	\$73.43	

Allan Hancock College

Warrant Register

Check Dates from 5/1/2025 to 5/31/2025

Bank Code: CT

Vendor Name	Description	Amount	Warrant
Amazon	Office/Operational Supplies, 4/22/25 - 5/30/25	\$153.62	
	Office/Operational Supplies for Tobacco Study,	\$539.95	
	Office/Operational Supplies, 4/22/25 - 5/30/25	\$17.59	
	OFFICE-OPERATIONAL SUPPLIES FOR LE,	\$176.86	
	LE INSTRUCTIONAL SUPPLIES: 07-02-24 TO 05-30-25	\$156.90	
	Supplies for ITS: 3/24/25 - 5/30/25	(\$136.89)	
	Supplies for ITS: 3/24/25 - 5/30/25	\$136.89	
	Dance Instructional Supplies 4/10/2025-5/30/2025	\$335.68	
	Dance Instructional Supplies 4/10/2025-5/30/2025	\$468.18	
	Office supplies 4/11/2025-5/30/2025	\$133.83	
	Dance Instructional Supplies: 4/24/25 - 5/31/2025	\$2,926.29	
	Physics Instructional Supplies: Jan 15, 2025 to	\$245.47	
	Operational Supplies for Early Childhood Studies	\$762.29	
	Operational Supplies for Early Childhood Studies	\$744.83	
	Operational Supplies for Early Childhood Studies	\$31.42	
	Operational Supplies for Early Childhood Studies	\$1,123.09	
	Operational Supplies for Early Childhood Studies	\$34.35	
	Operational Supplies:	\$65.87	
	Operational Supplies:	\$8.39	
	Instructional Supplies for Machining and	\$697.50	
	Instructional Supplies for Machining and	\$1,033.87	
	Instructional Supplies for Fire Academy,	\$50.90	
Instructional Supplies for Fire Academy,	\$54.16		
Instructional Supplies 1/30/25-5/30/25	\$39.96		
	\$12,685.49		CT 25057079
American Industrial Supply	Supplies for Maintenance, 11.14.2024 to 5.30.2025	\$26.81	
	\$26.81		CT 25057080
American Star Tours, Inc.	Bus Service - AHC Baseball on 4-22-25	\$1,865.00	
	Bus Service - AHC Track on 4-25-25	\$2,295.00	
	Bus Transportation to Santa Barbara for AHC Choir	\$1,400.00	
	Student Transportation to CSU Northridge	\$2,835.00	
	Student transportation to UC Santa Cruz and	\$4,440.00	
	\$12,835.00		CT 25057081
Shane Anderson	Reimbursement for food for Media Arts Advisory	\$286.00	
	\$286.00		CT 25057082
Apple Inc.	Mac Mini M4 - Part #: Z1CF	\$2,280.49	
	Magic Keyboard - USB-C	\$583.99	
	24" iMac M4 w/ Retina 4.5k Display,	\$1,583.40	
	Recycle Fee	\$5.00	
	24" iMac M4 w/ Retina 4.5k Display,	\$1,583.40	
	Recycle Fee	\$5.00	
	24" iMac M4 w/ Retina 4.5k Display,	\$1,583.40	
	Recycle Fee	\$5.00	
	\$9,218.08		CT 25057083
Applied Technology Group, Inc	MIC CORD FOR KMC65M, Item # E3A061110. Invoice #	\$516.56	
	FREIGHT	\$45.53	

Allan Hancock College

Warrant Register

Check Dates from 5/1/2025 to 5/31/2025

Bank Code: CT

Vendor Name	Description	Amount	Warrant
		\$562.09	CT 25057084
B&H Photo Video	Film Instructional Supplies 4/8/2025 - 5/30/2025	\$61.82	
	Film Instructional Supplies 4/8/2025 - 5/30/2025	\$421.43	
	Film Instructional Supplies 4/8/2025 - 5/30/2025	\$306.49	
	Photo Instructional Supplies 4/14/2025-5/30/2025	\$100.26	
	VIVOTEK AM-221 GOOSE NECK MOUNT KIT	\$134.13	
	VIVOTEK AM-314 POLE MOUNT BRACKET	\$45.62	
	Logitech 4K Meetup - Part #: LOMUCC120	\$2,174.78	
	Dell 24" Monitor	\$2,942.34	
	CYBERPOWER 4 OUTLT	\$84.83	
	TRIPP-LITE 208/230 VLTS	\$137.35	
	BELKIN 12 OUTLETS	\$226.20	
	COMPREHENSIVE-C STANDARD PC POWER CORD	\$103.31	
	CABLES 1' 18 AWG MONITOR POWER ADAPTER	\$48.40	
	EWASTE	\$80.00	
	TRIPP-LITE 208/230 VLTS	\$228.91	
		\$7,095.87	CT 25057085
Battery Systems Inc	Parking Permit Machine Batteries 7-1-24 to 5-30-25	\$366.19	
		\$366.19	CT 25057086
Bio-Rad Laboratories	0.2mL PCR Tubes w/Domed Caps. Part #: TWI0201EDU,	\$67.20	
	InstaGene Matrix	\$123.20	
	Freight	\$23.00	
	Packaging	\$5.00	
		\$218.40	CT 25057087
David Botsford	Provide mental health counseling, alcohol and drug	\$11,880.00	
	Provide mental health counseling, alcohol and drug	\$3,960.00	
		\$15,840.00	CT 25057088
Bremer Auto Parts	Supplies/parts for LE vehicles: 7/02/24 - 5/30/25.	\$5.22	
	Supplies/parts for LE vehicles: 7/02/24 - 5/30/25.	\$32.56	
	Supplies/parts for LE vehicles: 7/02/24 - 5/30/25.	\$6.95	
	Parts for Truck Driving Program	\$567.88	
	Parts for Truck Driving Program	\$64.16	
	Parts for Truck Driving Program	\$290.65	
	Parts for Truck Driving Program	\$108.64	
	Parts for Truck Driving Program	\$2,360.36	
	Supplies/parts for LE vehicles: 7/02/24 - 5/30/25.	\$405.55	
		\$3,841.97	CT 25057089
BRP Pharmaceuticals	Prescription Medication July 1, 2024- May 30, 2025	\$189.44	
	Prescription Medication July 1, 2024- May 30, 2025	\$25.54	
		\$214.98	CT 25057090
Califitness Equipment Expert	Fitness Equipment Maintenance, Invoice #41862.	\$407.00	
		\$407.00	CT 25057091
CalSoft Water	Calsoft Pro Reverse Osmosis System B 105	\$25.95	
	Calsoft Pro Reverse Osmosis System B 207	\$25.95	

13-34
Allan Hancock College
Warrant Register
Check Dates from 5/1/2025 to 5/31/2025
Bank Code: CT

Vendor Name	Description	Amount	Warrant
		\$51.90	CT 25057092
Camarenas Tire	Tires for LE Vehicles: 07-02-24 to 05-30-25.	\$1,227.04	
	Tires LE Vehicles 2-27-25 to 5-30-25	\$1,207.03	
		\$2,434.07	CT 25057093
Canon Financial Services Inc	Campus Graphics Copiers Lease	\$292.23	
	Campus Graphics Copiers Lease	\$5,249.92	
	Campus Graphics Canon Duplo 150 attachments Lease	\$700.43	
		\$6,242.58	CT 25057094
CDW Government Inc	Brother MFC-L3780CDW - multifunction printer -	\$494.80	
	Dell WD19S - Docking Station - USB-C, CDW No.	\$214.12	
	Dell 24 Monitor - P2425H, CDW No. 7878797	\$433.19	
	Dell Latitude 5550 (Version 2024) - AI Ready -	\$1,463.81	
	Recycling Fee	\$15.00	
		\$2,620.92	CT 25057095
Citrin Cooperman Advisors LLC	Additional Hours for Intune Initiatives Ongoing Ad	\$843.75	
		\$843.75	CT 25057096
Coast Diesel Service	Parts for Truck Driving Program	\$8,129.61	
	Labor for Truck Driving Program	\$2,134.00	
	Labor for Truck Driving Program	\$379.00	
	Labor for Truck Driving Program	\$195.00	
	Labor for Truck Driving Program	\$195.00	
	Labor for Truck Driving Program,	\$130.00	
	Labor for Truck Driving Program,	\$130.00	
	Labor for Truck Driving Program,	\$130.00	
		\$11,422.61	CT 25057097
Column Software PBC	Legal Advertising of the Espresso Stand Operations	\$289.24	
		\$289.24	CT 25057098
Community College League Of California	LIBRARY DATABASES INVOICE #15028	\$80,033.00	
		\$80,033.00	CT 25057099
Culligan/Central Coast Water Treatment	Bottled Water Delivery, Bldg. Q South Campus	\$71.15	
	Stand Rental (hot and cold)	\$11.00	
		\$82.15	CT 25057100
	Bottled Water Delivery, Bldg. P South Campus	\$64.80	
	Stand Rental (hot and cold)	\$11.00	
		\$75.80	CT 25057101
Cyber Copy Inc	Online posting of the Espresso Stand Operations	\$172.00	
		\$172.00	CT 25057102
Dataprint Corporation	Instructional Supplies for Architecture Program	\$249.02	
	Instructional Supplies for Architecture Program	\$502.75	
		\$751.77	CT 25057103
Dental Board of California	Application Fee for Approval of Infection Control	\$300.00	

Allan Hancock College

Warrant Register

Check Dates from 5/1/2025 to 5/31/2025

Bank Code: CT

Vendor Name	Description	Amount	Warrant
		\$300.00	CT 25057104
Dept Of Forestry & Fire Protection	Fire Control 3: Structural Fire Fighting B155	\$2,400.00	
		\$2,400.00	CT 25057105
	Common Passenger Vehicle Rescue Technician B155	\$2,400.00	
		\$2,400.00	CT 25057106
DMQ Catering LLC	Food purchase for SkillsUSA Meeting, 5/5/2025.	\$1,957.50	
	Food purchase for Career Readiness Academy	\$543.75	
		\$2,501.25	CT 25057107
Elevate Healthcare Inc	Premier Warranty Plan for Apollo Pre-Hospital	\$6,902.00	
		\$6,902.00	CT 25057108
Evisions LLC	IntelleCheck - Payroll Maintenance - Perpetual	\$474.00	
		\$474.00	CT 25057109
Fastenal	Filter, 16x25x2	\$302.73	
	Filter, 16x20x2	\$264.46	
		\$567.19	CT 25057110
Federal Express Corp	Mailings for Acct #1104-8488	\$33.37	
		\$33.37	CT 25057111
Follett Heg - Ahc Bookstore	Instructional Supplies: 7/02/24 - 5/30/25	\$112.50	
		\$112.50	CT 25057112
	Art Instructional Supplies 10/22/2024-5/30/2025	\$99.99	
		\$99.99	CT 25057113
	Instructional Supplies, 3/11/25 - 4/30/25.	\$15.93	
		\$15.93	CT 25057114
	Instructional Supplies, 3/11/25 - 4/30/25.	\$127.97	
		\$127.97	CT 25057115
	EOPS Student Supplies for Spring 2025	\$1,037.96	
		\$1,037.96	CT 25057116
Foodbank Of Santa Barbara County	Food for Foodshare and Basic Needs Food Pantry for	\$1,636.32	
		\$1,636.32	CT 25057117
	Food for Foodshare and Basic Needs Food Pantry for	\$410.13	
		\$410.13	CT 25057118
Foundation for California Community Colleges	Adobe Creative Cloud 6 Month Subscription	\$3,249.35	
		\$3,249.35	CT 25057119
Glorificate Coffee Delight LLC	Coffee Service for Basic Needs Open House,	\$150.00	
	Coffee Service for Basic Needs Open House,	\$150.00	
	Coffee Service for Reg Fest on 4/24/25. Invoice #	\$200.00	
	Coffee and Pastries for Students, Staff, and	\$400.00	
	Coffee and Pastries for Students. Staff, and	\$750.00	

Allan Hancock College

Warrant Register

Check Dates from 5/1/2025 to 5/31/2025

Bank Code: CT

Vendor Name	Description	Amount	Warrant
Glorificate Coffee Delight LLC	Coffee Service	\$200.00	
		\$1,850.00	CT 25057120
Graduate Communications	Career Education Digital Marketing Campaign, SOW	\$0.00	
	Career Education Digital Marketing Campaign, SOW	\$0.00	
	Career Education Digital Marketing Campaign, SOW	\$0.00	
	Career Education Digital Marketing Campaign, SOW	\$53,200.00	
		\$53,200.00	CT 25057121
Grainger Inc.	Sharps Container, Red per Invoice #9494393318.	\$244.52	
		\$244.52	CT 25057122
Graybar Electric	Ortronics TracJack 4Hole - Quote: 0248517170	\$90.04	
	TracJack C6 Clarity	\$755.60	
	Ortronics 25FT C6 Cable	\$629.45	
	Ortronics C6 5FT Patch Cable	\$644.98	
	Wiremold - 8FT White	\$140.50	
	Wiremold - 6FT Ivory	\$364.10	
		\$2,624.67	CT 25057123
Greenvale Tree Co	Remove Pine Tree Across From Student	\$1,680.00	
		\$1,680.00	CT 25057124
H&E Equipment Services Inc	Light Tower Manual Solar LED Tower	\$3,262.50	
	Property Tax Recovery Fee	\$24.47	
	Environmental Rental Fee	\$81.56	
		\$3,368.53	CT 25057125
Henry Schein Inc	Bib Eze Disposable White	\$37.91	
	Optim 1 Surface Cleaner Gallon	\$169.13	
	Headrest Covers 11.5"x10" White	\$63.82	
	Safe Tips EZ Refill	\$110.12	
	Topicale Xtra Anesthetic Berry Cherry	\$33.24	
	Mercury Spill Absorbent	\$101.39	
	X-Ray Sleeve 15x26	\$90.05	
	Essentials Cover Film Blue 6"Lx4"W	\$63.87	
	Ketac-Cem Cement Liquid	\$139.70	
	Speedclean For Autoclave	\$28.09	
	Cavit W Jar Medium Set	\$43.26	
	Confirm Biological Monitor Mail in	\$88.59	
	Coe Flex Refill Regular FS	\$59.82	
	Coe Flex Refill Package Regular	\$59.82	
	Isopropyl Alcohol 70%	\$83.94	
	Hysolate Flexi-Dam Rubber 6x6 med	\$57.08	
	Hazardous Charge	\$6.49	
	Syringe Sleeve AW 34 Sea 2.5x10	\$25.19	
	Niti Thermal upper 014 round	\$110.62	
		\$1,372.13	CT 25057126
Home Depot	Instructional Supplies for Fire Academy	\$119.59	
	Instructional Supplies for Fire Academy	\$24.90	
	Instructional Supplies for Fire Academy	\$66.66	
	OPERATIONAL SUPPLIES: 07-02-24 TO 05-30-25	\$516.39	

13-37
Allan Hancock College
Warrant Register
Check Dates from 5/1/2025 to 5/31/2025
Bank Code: CT

Vendor Name	Description	Amount	Warrant
		\$727.54	CT 25057127
Intermountain Lock And Security Supply	Schlage Key SC 20 per Invoice 4508537	\$100.60	
	Supplies per Invoice 4508907	\$275.50	
	Supplies per Invoice 4533843	\$82.51	
	Freight Charges	\$10.24	
		\$468.85	CT 25057128
International E-Z Up Inc	Enterprise 10x10 Shelter with Fully printed top, Shipping	\$2,198.00	
		\$54.81	
		\$2,252.81	CT 25057129
Jack's All American Plumbing	Labor-Service on M-100 Restrooms	\$400.00	
	Camera Equipment Charge	\$150.00	
	Cable Machine-Snake	\$30.00	
	Catchall for Items like tape, dope, solder, flux,	\$27.19	
		\$607.19	CT 25057130
Danielle Kaprelian	Keynote speaker, panelist and workshop presenter	\$4,000.00	
		\$4,000.00	CT 25057131
Keenan & Associates	Member Contribution-2024/2025 Repayment of Member	\$10,000.00	
		\$10,000.00	CT 25057132
Kelly Spicers Stores	Office Supplies - Paper, Wide Format and Bindery	\$4,089.29	
	Wide Format Stocks, Paper, Bindery	\$1,149.11	
		\$5,238.40	CT 25057133
Koehler Plumbing Inc	Furnish all labor and materials to remove and Bond	\$31,300.00	
		\$782.50	
		\$32,082.50	CT 25057134
Krueger International Inc	700 Series Files Mobile Ped-PenBox File	\$809.28	
	Pirouette Table, Fixed Training, Rectangular,	\$801.83	
	Ruckus, Single Post Pneumatic Adjustable Lectern on	\$817.72	
		\$2,428.83	CT 25057135
L.N. Curtis & Sons	**Leather Helmet Shield . Shield Model: 6-2	\$64.16	
	Black 880 MSA Cairns Traditional Helmet: * 4"	\$500.18	
		\$564.34	CT 25057136
Laguna Clay Company	BELT, PACIFICA, ROUND 42"- EACH	\$163.64	
	Packing and Handling Charge	\$4.95	
	Shipping Charges Estimated	\$8.70	
		\$177.29	CT 25057137
Jane Louise Lehr	Professional services: facilitate C6 LSAMP project	\$2,000.00	
		\$2,000.00	CT 25057138
Liebert Cassidy Whitmore	Legal services for Student Services	\$9,835.00	
		\$9,835.00	CT 25057139
Linde Gas & Equipment Inc.	Instructional Supplies 02/07/25 - 05/30/25	\$247.60	

Allan Hancock College

Warrant Register

Check Dates from 5/1/2025 to 5/31/2025

Bank Code: CT

Vendor Name	Description	Amount	Warrant
		\$247.60	CT 25057140
Littler Mendelson P.C.	Legal Services 4/02/25 (Re: Caroline Rein).	\$224.00	
	Legal Services 4/02/25 (Re: Tony Angelini).	\$224.00	
		\$448.00	CT 25057141
Lowes	ART Instructional Supplies 11/4/2024-5/30/2025	(\$171.31)	
	ART Instructional Supplies 11/4/2024-5/30/2025	\$338.88	
		\$167.57	CT 25057142
M & M Restaurant Supply	Gas Valve Kit, Honeywell, 24V, 1/2", Middleby,	\$652.50	
	Freight Charges	\$22.50	
		\$675.00	CT 25057143
Masters Notary Academy	Services to Conduct - Becoming a CA Notary Public	\$682.50	
		\$682.50	CT 25057144
Matheson Tri-Gas Inc	Instructional Supplies for Welding Tech Program	\$490.21	
		\$490.21	CT 25057145
Maya Restaurant	Food Purchase for Men's Support Group (MSG)	\$421.41	
	Delivery Fee	\$10.00	
		\$431.41	CT 25057146
McMaster-Carr Supply Co.	Instructional Supplies for Machining and	\$481.75	
	Operational Supplies for Machine Technology	\$6,424.80	
		\$6,906.55	CT 25057147
Metlife Small Market	INSURANCE PREMIUMS APR 2025	\$7,226.46	
		\$7,226.46	CT 25057148
Mission Linen Supply	Laundry Services for Automotive Technology Program	\$34.60	
	Laundry Services for Automotive Collision Repair:	\$21.13	
	Kitchen linen service for Culinary Arts,	\$51.45	
		\$107.18	CT 25057149
Motion Industries Inc	Super HC V Belt	\$68.30	
	Tri-Power Belt	\$153.23	
	Freight Charges	\$20.90	
		\$242.43	CT 25057150
Mountain Mike's Pizza	Dinner Purchase for the 41601 BASK (GED) End-of-	\$175.04	
	Delivery Fee	\$5.99	
		\$181.03	CT 25057151
Nicks Telecom	Labor for wiring in new Police unit, timer repairs	\$910.00	
	Whelen, core control point	\$500.25	
	Whelen door park module	\$130.50	
		\$1,540.75	CT 25057152
ODP Business Solutions LLC	Office Supplies: 07/01/2024 - 05/30/2025	\$120.89	
	Office Supplies: 07/01/2024 - 05/30/2025	\$59.56	
	Instructional Supplies, 1/24/25 - 5/30/25	\$170.74	
	Office Supplies	\$384.25	
	Office Supplies	\$101.77	
	Office Supplies, 11/14/24 - 5/30/25	\$55.64	

Allan Hancock College

Warrant Register

Check Dates from 5/1/2025 to 5/31/2025

Bank Code: CT

Vendor Name	Description	Amount	Warrant
ODP Business Solutions LLC	Office Supplies for July 1, 2024 to May 30, 2025	\$344.24	
	Office Supplies: 5/2/25 - 5/31/25	\$204.58	
	Office Supplies: 5/2/25 - 5/31/25	\$393.13	
	Office Supplies: 3/05/25 - 5/30/25	\$13.85	
	Office Supplies: 3/05/25 - 5/30/25	\$245.62	
	Office Supplies: 3/05/25 - 5/30/25	\$19.25	
	OPERATIONAL SUPPLIES: JULY 2024 - MAY 2025	\$60.21	
	Instructional Supplies 7/1/2024 - 5/31/2025	\$64.50	
	Instructional Supplies: 07-02-24 TO 05-30-25	\$322.54	
	Office supplies for Transfer Star Celebration,	\$301.89	
	Office Supplies: 3/05/25 - 5/30/25	\$2.31	
	Office Operational Supplies 7/1/24 to 5/30/25	\$163.55	
		\$3,028.52	CT 25057153
Old Town Shirt Factory	Embroidery: (5) Polo, Black/Chrcl Red Cap SS	\$92.44	
		\$92.44	CT 25057154
OverDrive, Inc	Applied to Application Licensing and Hosting:	\$750.00	
		\$750.00	CT 25057155
Pasco Scientific	Replacement Brush - Mechanical Equivalent of Heat,	\$217.50	
	Thermal Expansion Apparatus, Item #TD-8856	\$650.33	
	Detector Coil (400 Turn), Item #EM-6712	\$280.58	
	Basic Optics Light Source, Item #OS-8470	\$391.50	
	Shipping	\$26.10	
	\$1,566.01	CT 25057156	
Uri Pollack	Reimbursement for AHA PALS Online Certification	\$247.25	
	Reimbursement for ACLS Online Certification Course	\$252.25	
		\$499.50	CT 25057157
PPG Architectural Finishes Inc	Paint Supplies per Invoice 812320005058	\$56.84	
	PP SealG Primer Per Invoice 812320005159	\$37.43	
	Painting Supplies per Invoice 812320005466	\$165.78	
	Supplies per Invoice 812320005477	\$88.50	
	\$348.55	CT 25057158	
ProCare Janitorial Supply, Inc.	Supplies per Invoice 182137	\$4,129.52	
	Supplies per Invoice 182333	\$1,714.23	
	Supplies per Invoice 182333-1	\$37.95	
	Supplies per Invoice 182512-1	\$422.92	
	Vacuum, Sensor XP, 18 inch	\$974.79	
	Vacuum, Sensor XP, 12 inch	\$770.03	
	\$8,049.44	CT 25057159	
Quest Diagnostics	LABORATORY SERVICES FOR AHC STUDENTS	\$52.66	
		\$52.66	CT 25057160
Trudi Radtke	Keynote speaker, panelist and workshop presenter	\$4,000.00	
		\$4,000.00	CT 25057161
Safety-Kleen Systems, Inc	Used Oil Service Recovery Fee, Invoice #97055294.	\$87.00	
	Used Oil-Automotive	\$93.50	

13-40
Allan Hancock College
Warrant Register
Check Dates from 5/1/2025 to 5/31/2025
Bank Code: CT

Vendor Name	Description	Amount	Warrant
		\$180.50	CT 25057162
Santa Barbara Co Env Health Svc	Annual Hazardous Materials Permit Fee for 2025	\$1,192.40	
		\$1,192.40	CT 25057163
	Annual Hazardous Materials Permit Fee for 2025	\$1,701.70	
		\$1,701.70	CT 25057164
	Annual Hazardous Materials Permit Fee for 2025	\$1,387.10	
		\$1,387.10	CT 25057165
Santa Maria BBQ Outfitters	30"x20" Santa Maria BBQ Grill w/ Carbon Steel	\$2,153.25	
	30"x20" Sized Smoker BBQ w/ Carbon Steel Expanded	\$1,223.44	
		\$3,376.69	CT 25057166
Santa Maria Produce Golf	2025 SANTA MARIA PRODUCE GOLF TOURNAMENT	\$900.00	
		\$900.00	CT 25057167
Santa Maria Sun LLC	Quarter-page Display Ad 2025 Summer Fall Reg	\$306.00	
	Digital Companion Ad to run on santamariasun.com	\$45.00	
		\$351.00	CT 25057168
Santa Ynez Valley Union High School District	Career Exploration Day Bus Transportation	\$750.00	
		\$750.00	CT 25057169
Save Mart Supermarkets	Food Supplies for Children's Center,	\$351.98	
		\$351.98	CT 25057170
Eva Schiorring	External evaluator for grant project evaluation	\$12,810.00	
		\$12,810.00	CT 25057171
Megan Selby	Reimbursement for materials for noncredit FASN	\$226.00	
		\$226.00	CT 25057172
SLO Safe Ride	Bus Service - AHC Track Team on 5-2-25 Thru 5-4-25	\$5,830.00	
		\$5,830.00	CT 25057173
Richard Soto	Reimbursement for cake purchased for Career	\$27.99	
		\$27.99	CT 25057174
Source Graphics	Office Supplies - Wide format Paper and Media	\$796.31	
		\$796.31	CT 25057175
Specialty Constructors Services Inc	The contractor shall furnish all labor, materials,	\$23,106.85	
	Provide all labor, materials, equipment, utility	\$304,151.05	
		\$327,257.90	CT 25057176
Spiraledge Inc	Hoodie M Grey Heather XLG Item #8213294-0024.	\$60.90	
	Hoodie M Grey Heather LG Item #8213294-0021	\$60.90	
	Hoodie Black XLG Item #8213294-0009	\$60.90	
	Hoodie Black XLG Item #8213294-0007	\$182.70	
	Hoodie Black LG Item #8213294-0004	\$609.00	
	Hoodie Black Medium Item #8213294-0005	\$669.90	
	Hoodie Black Small Item #8213294-0006	\$365.40	

Allan Hancock College

Warrant Register

Check Dates from 5/1/2025 to 5/31/2025

Bank Code: CT

Vendor Name	Description	Amount	Warrant
		\$2,009.70	CT 25057177
Splash N Dash	Car Wash Services for Allan Hancock College	\$249.90	
		\$249.90	CT 25057178
Subway	Food for Auto Body Advisory Committee meeting,	\$79.45	
		\$79.45	CT 25057179
TeamDynamix Solutions LLC	SaaS Licenses - Universal License for the term	\$24,744.28	
	SaaS Licenses - iPaaS for the term starting	\$20,600.00	
	SaaS Licenses - Asset Discovery for the term	\$2,318.61	
		\$47,662.89	CT 25057180
Testa Catering	Food for Early Childhood Studies Advisory	\$529.50	
		\$529.50	CT 25057181
The Baldwin Group	ACA Consulting 7-1-24 to 6-30-25	\$3,250.00	
		\$3,250.00	CT 25057182
Trojan Petroleum, Inc	Unleaded Gas per Invoice 332881	\$5,890.09	
		\$5,890.09	CT 25057183
Tropics	Aquarium Maintenance Service (2 visits/month):	\$350.00	
		\$350.00	CT 25057184
Uline Inc	Bindery Supplies, Lamination	\$196.94	
		\$196.94	CT 25057185
USA Custom Pad Corp	BOOK STYLE 17 PT LEATHERETTE CERTIFICATE COVER	\$330.00	
	SET-UP/RUN CHARGES/DIES	\$35.00	
	ACETATE PROTECTOR SHEET	\$25.00	
	ESTIMATED/BILLED SHIPPING CHARGES	\$53.92	
		\$443.92	CT 25057186
VTC Enterprises	Collection of Recycling Paper on Main Campus,	\$800.00	
	Collection of Recycling Paper on Main Campus,	\$1,000.00	
		\$1,800.00	CT 25057187
Marina Washburn	Provide specialist support services for the	\$4,250.00	
		\$4,250.00	CT 25057188
Washington Music Center	Yamaha YHR-567 Intermediate Horn; Key of F/BB;	\$6,014.03	
		\$6,014.03	CT 25057189
Yankee Book Peddler Inc	LVC Library books 3.11.25 - 5.30.25	\$76.79	
	LVC Library books 3.11.25 - 5.30.25	\$101.80	
		\$178.59	CT 25057190
Anisah Abadia	Manual Refund Submitted	\$2.00	
		\$2.00	CT 25057191
Natalia Bautista	Manual Refund Submitted	\$150.00	
		\$150.00	CT 25057192
Oscar Chavez-Puente	Manual Refund Submitted	\$154.00	
		\$154.00	CT 25057193

Allan Hancock College

Warrant Register

Check Dates from 5/1/2025 to 5/31/2025

Bank Code: CT

Vendor Name	Description	Amount	Warrant
Juan Gomez Mora	Manual Refund Submitted	\$185.00	
		\$185.00	CT 25057194
Donald Graziano	Manual Refund Submitted	\$87.37	
		\$87.37	CT 25057195
Jesus Magdaleno Bravo	Manual Refund Submitted	\$28.00	
		\$28.00	CT 25057196
Jessica Martinez Garcia	Manual Refund Submitted	\$350.00	
		\$350.00	CT 25057197
Christopher Maselli	Manual Refund Submitted	\$412.00	
		\$412.00	CT 25057198
Gabriela Menendez	Manual Refund Submitted	\$150.00	
		\$150.00	CT 25057199
Rubi Montelongo	Manual Refund Submitted	\$69.00	
		\$69.00	CT 25057200
Ofelia Morales	Manual Refund Submitted	\$150.00	
		\$150.00	CT 25057201
Ashley Ortega	Manual Refund Submitted	\$100.00	
		\$100.00	CT 25057202
Daniil Popovich	Manual Refund Submitted	\$500.00	
		\$500.00	CT 25057203
Jasmin Ramirez-Mejia	Manual Refund Submitted	\$462.00	
		\$462.00	CT 25057204
Graciela Ramos	Manual Refund Submitted	\$500.00	
		\$500.00	CT 25057205
Arianna Ruiz	Manual Refund Submitted	\$1,507.00	
		\$1,507.00	CT 25057206
Indira Ruiz Carpio	Manual Refund Submitted	\$500.00	
		\$500.00	CT 25057207
Ariana Salas	Manual Refund Submitted	\$201.00	
		\$201.00	CT 25057208
Gavin Shorts	Manual Refund Submitted	\$130.00	
		\$130.00	CT 25057209
Anthony Tapia Corona	Manual Refund Submitted	\$610.00	
		\$610.00	CT 25057210
Jacob Zepeda	Manual Refund Submitted	\$1,257.00	
		\$1,257.00	CT 25057211
Atkinson Andelson Loya Ruud And Romo	Reg 4.2-5.25 Ramirez, Ruben	\$475.00	

13-43
Allan Hancock College
Warrant Register
 Check Dates from 5/1/2025 to 5/31/2025
 Bank Code: CT

Vendor Name	Description	Amount	Warrant
		\$475.00	CT 25057212
Barrett, Robert	INTERVIEW REIMBURSEMENT 5.2025	\$267.40	
		\$267.40	CT 25057213
Brown, Autumn	INTERVIEW REIMBURSEMENT 5.2025	\$543.28	
		\$543.28	CT 25057214
Robert Bryant	Open Mileage 4.1-29.25	\$316.26	
		\$316.26	CT 25057215
Jovany Cardenas Vargas	Open Mileage 4.22,24.25	\$8.33	
	Open Mileage 4.22,24.25	\$0.00	
	Open Mileage 4.22,24.25	\$0.00	
		\$8.33	CT 25057216
Marcus Carson	Open Mileage 4.30.25	\$84.00	
		\$84.00	CT 25057217
Martin Castillo	Open Mileage 4.1-29.25	\$167.37	
		\$167.37	CT 25057218
City Of Santa Maria	Disposal Site Landfill Fees,	\$195.00	
		\$195.00	CT 25057219
Sandra Cruz Martinez	Open Mileage 4.9.2025	\$35.91	
		\$35.91	CT 25057220
Alicia Delgadillo	Open Mileage 4.30.25	\$38.92	
		\$38.92	CT 25057221
Alejandra Enciso	Annual Trustee Conf Lake Tahoe, CA	\$707.86	
		\$707.86	CT 25057222
Holland, Trevor Lee	INTERVIEW REIMBURSEMENT 5.25	\$600.00	
		\$600.00	CT 25057223
Maribel Landey	CACCRAO conf. San Diego, CA	\$1,295.91	
		\$1,295.91	CT 25057224
Rosi Lopez Navarro	Open Mileage 3.3-21.25	\$51.24	
	Open Mileage 4.1-30.25	\$86.94	
		\$138.18	CT 25057225
Alexa Martinez	Open Mileage 4.1-25.25	\$239.68	
		\$239.68	CT 25057226
Janet McGee	Exec Asstnt Workshop Lake Tahoe, CA	\$815.98	
		\$815.98	CT 25057227
Jose Millan	12.9 12.10,11 3.12,24 5.1.25	\$68.24	
		\$68.24	CT 25057228
Milligan, Kristin	INTERVIEW REIMBURSEMENT 5.2025	\$300.00	
		\$300.00	CT 25057229
Monica Sofia Morelos Vivar	Open Mileage 4.1-30.25	\$47.60	

Allan Hancock College

Warrant Register

Check Dates from 5/1/2025 to 5/31/2025

Bank Code: CT

Vendor Name	Description	Amount	Warrant
		\$47.60	CT 25057230
Nye, Mathew	INTERVIEW REIMBURSEMENT 5.2025	\$300.00	
		\$300.00	CT 25057231
Pacific Gas & Electric Company	Electricity Services 7.1.2024- 6.30.2025	\$43,976.35	
	Electricity Services 7/1/2024 - 6/30/2025	\$11,689.92	
		\$55,666.27	CT 25057232
	Electricity Services 7/1/2024 - 6/30/2025	\$829.83	
	Electricity Services 7/1/2024 - 6/30/2025	\$220.59	
		\$1,050.42	CT 25057233
Greg Pensa	Annual Trustee Conf Lake Tahoe, CA	\$1,381.88	
		\$1,381.88	CT 25057234
Ruben Ramirez	AALRR Conf. Shell Beach, CA	\$99.54	
		\$99.54	CT 25057235
Santa Maria Joint Union High School District	RET SCHOLARSHIP22-23FREDYSANCHEZ RI	\$500.00	
	RET SCHOLARSHIP22-23FREDYSANCHEZ RI	\$0.00	
		\$500.00	CT 25057236
Feride Schroeder	PHSC Colardo Plateau 6.2-6.13.25	\$1,000.00	
		\$1,000.00	CT 25057237
Richard Soto	Open Mileage 4.2,9,28,30.25	\$40.60	
		\$40.60	CT 25057238
Tate, Dana	INTERVIEW REIMBURSEMENT 5.2025	\$300.00	
		\$300.00	CT 25057239
Kevin Walthers	Annual Trustee Conf Lake Tahoe, CA	\$1,302.33	
		\$1,302.33	CT 25057240
13 Stars Media	Quarter-page Display Ad 2025 Summer Fall Reg	\$380.00	
		\$380.00	CT 25057241
3AM Technologies LLC	SimServe On-Site Training Implementation Charges	\$2,300.00	
		\$2,300.00	CT 25057242
4allpromos	Vinello Shatterproof Plastic Stemless Wine Glass	\$871.96	
	One Time Set Up Charge	\$54.38	
	UPS Ground	\$428.04	
		\$1,354.38	CT 25057243
4imprint Inc.	Serged Closed-Back Table Throw - 6', Item #2212.	\$463.28	
	Freight	\$34.45	
	Gildan Softstyle Fleece Hoodie - Embroidered,	\$844.73	
	Gildan Softstyle Fleece Hoodie - Embroidered,	\$328.51	
	Freight	\$60.02	
	Freight	\$23.34	
	Serged Closed-Back Table Throw - 6', Item #2212.	\$179.44	
	Freight	\$11.48	

Allan Hancock College

Warrant Register

Check Dates from 5/1/2025 to 5/31/2025

Bank Code: CT

Vendor Name	Description	Amount	Warrant
		\$1,945.25	CT 25057244
Acquia Inc	Acquia Optimize - Standard Package	\$7,549.90	
		\$7,549.90	CT 25057245
Acupuncture Center of Santa Maria	SERVICE AGREEMENT 21 AUGUST 2024 THRU 30 JUNE 2025	\$8,175.00	
		\$8,175.00	CT 25057246
Araceli Agosto	Reimbursement for uniform pants, 5/9/25.	\$180.50	
		\$180.50	CT 25057247
Air Resources Board	Portable Equipment Registration Fees	\$735.00	
		\$735.00	CT 25057248
Akeso Occupational Health	TB, X-ray, Medical Physicals: 7-01-24 to 6-30-25	\$85.00	
		\$85.00	CT 25057249
Amazon	LVC LRC Lola Dority book funds 3.25.25 - 5.30.25	\$25.89	
	Office Supplies, 4/29/25 - 5/30/25	\$15.32	
	Office Supplies, 4/29/25 - 5/30/25	\$39.39	
	OFFICE/OPERATIONAL SUPPLIES, 5/6/25 - 5/30/25	\$313.54	
	Instructional Supplies for ECS	\$160.92	
	FASN Instructional Supplies AG,	\$374.50	
	Physics supplies, Jan. 29 through May 30, 2025	\$342.17	
	Geology supplies, April 1 thru May 30, 2025	\$299.35	
	Medify MA-50 Genuine Replacement Filter	\$64.15	
	Instructional Supplies for Electronics Program	\$263.89	
	Instructional Supplies for Electronics Program	\$34.89	
	Instructional Supplies for Electronics Program	\$21.52	
	Instructional Supplies for Electronics Program	\$638.86	
	Instructional Supplies for Electronics Program	\$221.74	
	Instructional Supplies for Electronics Program	\$36.96	
	Operational Supplies - Transportation,	\$41.28	
	Uniforms for FSEMS Mechanic	\$89.71	
	Office Operational Supplies	\$214.72	
	Instructional supplies 4/11/2025-5/30/2025	\$43.02	
	Geology supplies, 9-4-2024 thru 5-30-2025	\$150.08	
	Film Instructional Supplies, 4/8/25 - 5/30/25	\$122.45	
	Instructional Supplies, 4/14/25 - 5/30/25	\$1,342.64	
	Instructional Supplies for Auto Body Tech Program,	\$1,006.98	
	Office Supplies, 5/6/25 - 5/30/25	\$210.54	
	Office Supplies, 5/6/25 - 5/30/25	\$42.61	
	BOOKS FOR LIBRARY, 3/25/25 - 5/30/25	\$117.73	
	BOOKS FOR LIBRARY, 3/25/25 - 5/30/25	\$90.49	
	BOOKS FOR LIBRARY, 3/25/25 - 5/30/25	\$141.72	
	Art Gallery Office/Operational Supplies,	\$438.85	
	Supplies for ITS: 3/24/25 - 5/30/25	\$651.42	
	LETS CAMP Folding Chair 2pk	\$390.15	
	Fulmoon 12 pc yardstick set	\$40.22	
	GoSports Solid Wood Cornhole set 4ft x 2ft	\$903.65	
	Ecotez 6 pk Painters Drop Cloth	\$9.78	
	Pro Grade Paint brush Set 24 pk	\$19.49	

Allan Hancock College

Warrant Register

Check Dates from 5/1/2025 to 5/31/2025

Bank Code: CT

Vendor Name	Description	Amount	Warrant
Amazon	ScotchBlue Painters Tape 6 rolls	\$20.32	
	Science Lab Supplies July 1, 2024-May 30, 2025	\$180.40	
	Supplies for Automotive Tech Program: 4/10/25 -	\$88.05	
	Instructional Supplies 1/30/25-5/30/25	\$18.45	
	Office Operational Supplies ABS, 4/11/25 - 5/30/25	\$89.14	
	BOOKS FOR LIBRARY,	\$95.97	
	Dance Office/Operational Supplies 4/10/2025-	\$2,264.66	
	Instructional supplies 4/11/2025-5/30/2025	\$886.06	
	BRINKS Heavy Duty Padlock with Key - 70mm Discus	\$152.68	
	HZSY Padlocks Keyed Alike, Pack of 24, Laminated	\$147.88	
	Yooleantu Manual 20mm Vial Crimper and Capper	\$118.41	
	GUEDEL Disposable Oral Airway Set	\$91.32	
	Office/Operational Supplies 7/2/24-5/30/25	\$135.92	
	Instructional Supplies 1/30/25-5/30/25	(\$19.58)	
	Instructional Supplies 1/30/25-5/30/25	(\$19.58)	
	Instructional Supplies 1/30/25-5/30/25	(\$19.58)	
	Drama Instructional Supplies 4/11/2025-5/30/2025	\$148.80	
	Instructional Supplies, 3-28-25 to 5-30-25	\$390.41	
	Office supplies 4/11/2025-5/30/2025	\$113.57	
	Global Industrial 12W Double Folding Security	\$842.85	
	Instructional Supplies, 7/01/24 - 5/30/25	\$111.21	
	Instructional Supplies HUSV, 4/11/25 - 5/30/25	\$204.49	
	OPUX lunch box-dark grey	\$751.61	
	Laptop Case Sleeve 15.6in	\$432.39	
	Office Supplies, 4/29/25 - 5/30/25	\$90.24	
	Office Supplies, 4/29/25 - 5/30/25	\$232.05	
	Instructional Supplies 4/14/25-5/30/25	\$136.00	
	Operational Supplies - Children's Center,	(\$107.65)	
	Operational Supplies - Children's Center,	(\$107.65)	
	Operational Supplies - Children's Center,	\$112.24	
	Operational Supplies - Children's Center,	\$484.43	
	Operational Supplies - Children's Center,	\$142.97	
	Operational Supplies - Children's Center,	\$72.25	
	Office/Operational Supplies, 1/31/25 to 5/30/25	\$0.31	
	Operational supplies for maintenance - 2.6.2025 to	\$169.29	
	Film Instructional Supplies 5/8/25-5/30/25	\$112.36	
	Office supplies and print shop supplies	\$45.65	
	Geology Instructional Supplies: April 17, 2025 -	\$398.85	
	Instructional Supplies for MESA/STEM,	\$137.25	
	Awards Banquet supplies May 2, 2025	\$547.75	
	Awards Banquet supplies May 2, 2025	\$257.49	
	FASN instructional supplies LVC	\$321.49	
	FASN instructional supplies LVC	\$139.91	
	Instructional Supplies, 3-28-25 to 5-30-25	\$218.31	
	Instructional Supplies for CA	\$98.94	
	ECSN FASN Instructional Supplies,	\$90.22	
	FASN Instructional Supplies AG,	\$24.99	
	FASN Instructional Supplies AG,	\$27.04	
	FASN Storage Supplies: 4/9/25 - 5/30/25	\$46.49	
	Geology supplies, 9-4-2024 thru 5-30-2025	\$45.57	
	Office/Operational Supplies, 4/22/25 - 5/30/25	(\$74.16)	

13-47

Allan Hancock College

Warrant Register

Check Dates from 5/1/2025 to 5/31/2025

Bank Code: CT

Vendor Name	Description	Amount	Warrant
Amazon	Office/Operational Supplies, 4/22/25 - 5/30/25	\$123.07	
		\$19,932.17	CT 25057250
American Industrial Supply	Instructional Supplies	\$340.31	
	Instructional Supplies	\$321.76	
		\$662.07	CT 25057251
American Medical Technologists	RMA Certification Exam Application Fees - BULK	\$3,150.00	
		\$3,150.00	CT 25057252
American Printing & Promotions	CUSTOM AIRTAG CASE PROTECTIVE LEATHER - BLUE, \$1,821.56		
	SET-UP CHARGE CUSTOM AIRTAG CASE	\$67.97	
	PROOF CHARGE CUSTOM AIRTAG CASE	\$15.00	
	SHIPPING CHARGE CUSTOM AIRTAG CASE	\$50.00	
	MEGAPHONE - ROYAL BLUE, WHITE IMPRINT SPIKE DOG,	\$340.94	
	SET UP CHARGE MEGAPHONE ROYAL BLUE	\$59.81	
	GRAPHIC DESIGN TYPESETTING (ALL)	\$35.00	
	PROOF CHARGE MEGAPHONE ROYAL BLUE	\$15.00	
	SHIPPING CHARGE MEGAPHONE ROYAL BLUE	\$70.00	
		\$2,475.28	CT 25057253
American Star Tours, Inc.	Bus Service - AHC Track on 3-28-25	\$2,915.00	
		\$2,915.00	CT 25057254
Arrow Screw Products, Inc	SPARK PLUG ASSEMBLY	\$1,875.00	
		\$1,875.00	CT 25057255
B&H Photo Video	Film Instructional Supplies 4/8/2025 - 5/30/2025	\$209.43	
	DELL OP7020 SFF (I5-14500, 16GB, 512GB/W11P/REG)	\$946.69	
		\$1,156.12	CT 25057256
Bilingual Interpreting Service	Professional live Spanish translation service for	\$600.00	
		\$600.00	CT 25057257
Blackhawk Network, Inc	Plastic Promotional Visa USD Generic 12 Mo. gift	\$13,000.00	
	Processing fee	\$305.50	
	Shipping	\$25.25	
		\$13,330.75	CT 25057258
Blue Ridge Scientific Materials	Kaolinite, Quote dated 2/11/25.	\$32.85	
	Potassium Feldspar	\$44.85	
	Estimated Shipping Cost	\$10.00	
		\$87.70	CT 25057259
Bowls On The Go	Catering bowls for Career Center	\$815.62	
		\$815.62	CT 25057260
Bremer Auto Parts	Supplies/parts for LE vehicles: 7/02/24 - 5/30/25.	\$56.47	
	Operational Supplies for EMS Academy	\$297.92	
	Supplies/parts for LE vehicles: 7/02/24 - 5/30/25.	\$14.12	
		\$368.51	CT 25057261

13-48
Allan Hancock College
Warrant Register
Check Dates from 5/1/2025 to 5/31/2025
Bank Code: CT

Vendor Name	Description	Amount	Warrant
BRP Pharmaceuticals	Prescription Medication July 1, 2024- May 30, 2025	\$20.96	CT 25057262
	Prescription Medication July 1, 2024- May 30, 2025	\$279.35	
		\$300.31	
Cabrillo Community College District	Cost-Reimbursement Subaward Agreement for	\$5,718.97	CT 25057263
		\$5,718.97	
California Department Of Justice	Fingerprint Apps. Invoice #813226.	\$928.00	CT 25057264
	Fingerprint FBI	\$119.00	
	Child Abuse Index CK	\$60.00	
	15/30 SRCHG DSS Billed	\$40.00	
		\$1,147.00	
Camarenas Tire	Tires LE Vehicles 2-27-25 to 5-30-25	\$1,654.04	CT 25057265
	Parts for truck driving class	\$1,140.00	
	Labor for Truck Driving Class, 10/17/24 - 5/30/25	\$300.00	
		\$3,094.04	
Carr's Boot Shop	Safety boots for employees 4-1-25 to 6-30-25	\$217.49	CT 25057266
		\$217.49	
Central City Tool Supply	Instructional Supplies	\$199.99	CT 25057267
		\$199.99	
Child Educational Center	OCP Professional Development Certification:	\$375.00	CT 25057268
		\$375.00	
City of Buellton	River View Park Site Rental Fees for Retreat on	\$280.00	CT 25057269
		\$280.00	
Crescendo Education Group LLC	Grading for Equity Online Course, Invoice #9810-97	\$6,268.00	CT 25057270
		\$6,268.00	
Cubanissimo Llc	Food Catering for CAN-TRIO Banquet, 5/9/25.	\$1,248.82	CT 25057271
	Food Catering for CAN-TRIO Banquet to serve an	\$307.52	
		\$1,556.34	
Dataprint Corporation	Instructional Supplies for Architecture Program	\$38.02	CT 25057272
		\$38.02	
Victor DeAlba	Independent contractor agreement to provide	\$1,785.00	CT 25057273
		\$1,785.00	
Vicki Edralin	Balloon and Event Decoration for CAN-TRIO Banquet	\$1,750.00	CT 25057274
	Graduation Ballons and Backdrop for 2025 DREAM End	\$2,500.00	
		\$4,250.00	
Empower TCT Inc	Provide 4-Hour Training Session at FKCE Conference	\$2,500.00	CT 25057275
		\$2,500.00	
Engel and Gray Inc	Bin Rental	\$171.00	
	Franchise Fee	\$6.19	
	Green waste Hauling Fee	\$125.00	
	Waste Handling	\$147.60	

Allan Hancock College

Warrant Register

Check Dates from 5/1/2025 to 5/31/2025

Bank Code: CT

Vendor Name	Description	Amount	Warrant
Engel and Gray Inc	Fuel Surcharge	\$13.63	
		\$463.42	CT 25057276
Fatte's Pizza of Santa Maria	Food Purchase for UTC Workshop: "I Got Accepted, Delivery Fee	\$66.32	
	Gratuity	\$6.00	
	FOOD FOR TUTOR TRAINING ON MAY 8, 2025	\$300.00	
		\$378.32	CT 25057277
Federal Express Corp	Mailings for Acct #1104-8488	\$32.13	
		\$32.13	CT 25057278
Myrna Flores	Reimbursement for Picture Frames	\$54.32	
		\$54.32	CT 25057279
Foodbank Of Santa Barbara County	Food for Foodshare and Basic Needs Food Pantry for	\$1,061.87	
		\$1,061.87	CT 25057280
Frank Diaz Consulting	Parts for the Paper cutter, cut bottoms and panel	\$425.00	
		\$425.00	CT 25057281
Glorificate Coffee Delight LLC	Coffee service for Basic Needs Open House, 3/28/25	\$150.00	
		\$150.00	CT 25057282
GMG Medical Solutions	Hill Rom P3200 Versacare Bed w/Foam Mattress Shipping	\$4,991.63	
		\$1,400.00	
		\$6,391.63	CT 25057283
Grainger Inc.	Office Supplies, 4/11/25 - 5/30/25	\$154.11	
	Light Bulb, HID Led, 4W per Inv. 9496382897	\$379.89	
	Battery, 12 VDC per Invoice 9507176460	\$232.90	
	Safety Sign, 10x14, Vinyl per Inv. 9503899156	\$54.29	
		\$821.19	CT 25057284
Hardy Diagnostics	Science Lab Supplies July 1, 2024-May 30, 2025	\$109.83	
	Science Lab Supplies July 1, 2024-May 30, 2025	\$202.60	
		\$312.43	CT 25057285
Lisa Hernandez	Reimbursement for postage for sending POST Pellet	\$7.44	
		\$7.44	CT 25057286
Home Depot	Lincoln Flux Brazing Rods 1/8" 1LB	\$62.16	
	15 IN Angle Broom and Step on Dust	\$43.37	
	Tip Cleaner/Host	\$47.74	
	Lincoln Flint Striker W Flints	\$29.30	
	Husky 3" C-Clamp	\$169.13	
	Energizer 2450 1-Pack	\$29.88	
	Diablo 4-1/2"X1/4"X7/8" MTL DC Grind	\$27.03	
	Department supplies from 7/01/24 - 5/30/25	\$107.66	
	Department supplies from 7/01/24 - 5/30/25	\$93.08	
	Instructional Supplies for Home Depot,	\$176.08	
	Instructional Supplies for Fire Academy	\$2.13	
	Instructional Supplies for Fire Academy	\$271.10	
	Supplies per Invoice 527023	\$20.06	

Allan Hancock College

Warrant Register

Check Dates from 5/1/2025 to 5/31/2025

Bank Code: CT

Vendor Name	Description	Amount	Warrant	
Home Depot	Supplies per Invoice 6514092	\$69.61		
	Supplies per Invoice 5520312	\$72.80		
	Supplies per Invoice 5532866	\$55.30		
	Supplies per Invoice 9514474	\$79.33		
	Supplies per Invoice 3520685	\$59.73		
	Supplies per Invoice 7342321	\$428.52		
	Supplies per Invoice 7521594	\$13.35		
	Supplies per Invoice 3553129	\$134.68		
	Supplies per Invoice 6540455	\$44.39		
	Supplies per Invoices 5021069	\$79.61		
	CAL LBR Fee, Invoice 5021069	\$0.72		
	Supplies per Invoice 2550634	\$35.64		
	Supplies per Invoice 8016029	\$104.03		
	CA LBR Fee, Invoice 8016029	\$0.21		
	Supplies per Invoice 6532919	\$36.63		
	Supplies per Invoice 5550969	\$117.32		
	Supplies per Invoice 1542155	\$57.57		
	Supplies per Invoice 9516539	\$116.21		
	Instructional Supplies for Fire Academy	\$368.66		
	Supplies per Invoice 7512241	(\$23.97)		
	Rtcht-SCKT56 PC, MKE 3/8 IN	\$205.54		
	Supplies per Invoice 9511944	\$22.94		
	Supplies per Invoice 7512241	\$44.19		
	Supplies per Invoice 9514468	\$202.23		
	GL Recy Fee, Invoice 9514468	\$3.00		
	Supplies per Invoice 8546054	\$101.12		
	GL Recy Fee, Invoice 8546054	\$1.50		
	Supplies per Invoice 3530341	\$68.45		
			\$3,578.03	CT 25057287
	Home Motors	Retainer, Part #15960325 per Invoice 110114 CVW	\$41.65	
Guard Package per Invoice #107571		(\$87.82)		
Guard Package per Invoice #107571		\$87.82		
		\$41.65	CT 25057288	
John Hood	Reimbursement for 3D Art instructional supplies,	\$100.75		
		\$100.75	CT 25057289	
Jaime's Upholstery Services	Seat Cover Repair per Invoice 1369	\$119.62		
	Labor Charges	\$280.00		
		\$399.62	CT 25057290	
Jay Cee Trophy	Shooting star acrylic trophy for 2025 UTC Transfer	\$100.05		
	Laser Text and Logo	\$25.00		
		\$125.05	CT 25057291	
Job Advertising	Job Advertising Services Invoice #12093763	\$1,443.00		
	Job Advertising Services Invoice #12093764	\$1,148.00		
		\$2,591.00	CT 25057292	
Johnson Plastics Plus	Engraver Supplies	\$724.90		
		\$724.90	CT 25057293	

Allan Hancock College

Warrant Register

Check Dates from 5/1/2025 to 5/31/2025

Bank Code: CT

Vendor Name	Description	Amount	Warrant
JplusJ Photography	Photo Booth Services for Graduation on 05/23/25: Luxury Booth Package: 2nd Booth	\$400.00	CT 25057294
		\$413.00	
		\$813.00	
Colleen Kelly	Ann Foxworthy Gallery Guest Speaker: Dichotomy of	\$250.00	CT 25057295
		\$250.00	
Krueger International Inc	MyPlace Rectangle, Concealed Glides, Non-Contrast Furniture for the AHC Foundation per Quotation #24	\$7,471.39	CT 25057296
		\$2,114.99	
		\$9,586.38	
La Tapatia Bakery	Cake for AIM to Dream Center and Puente Graduation	\$110.00	CT 25057297
		\$110.00	
Linde Gas & Equipment Inc.	Science Lab Supplies October 30, 2024-May 30, 2025 Instructional Supplies 02/07/25 - 05/30/25	\$123.03	CT 25057298
		\$1,008.80	
		\$1,131.83	
Link-Systems International Inc	Online Tutoring via NetTutor -April 2025 Online Tutoring via NetTutor -April 2025	\$2,300.00	CT 25057299
		\$2,300.00	
		\$4,600.00	
Ronald Lovell	Reimbursement for instructional items for Culinary	\$407.12	CT 25057300
		\$407.12	
Maaco Auto Painting & Bodyworks	Labor Charges per Invoice 24710 Parts-Paint Materials Sublet - Freight	\$1,168.50	CT 25057301
		\$692.22	
		\$288.00	
		\$2,148.72	
Mariachi Voces Tapatias	Performance of live music for Noncredit	\$1,400.00	CT 25057302
		\$1,400.00	
Masters Notary Academy	Services to Conduct - Loan Signing Specialist	\$180.00	CT 25057303
		\$180.00	
Dorine Mathieu	Reimbursement for supplies for MESA/STEM Reimbursement for supplies for MESA/STEM	\$18.52	CT 25057304
		\$61.25	
		\$79.77	
McKesson Medical Surgical Inc	Pain off tab item #1232803	\$17.26	
	Decorel item #1221162	\$24.21	
	Refresh drops item #852647	\$18.78	
	Loratadine item #1111728	\$103.80	
	HCG control kit item #951315	\$31.94	
	PPD tubersol item #162671	\$334.42	
	urine control item # 976926	\$84.87	
	Shipping on ice	\$13.05	
	Strep A test Item #951316	\$50.96	
	Preg Test Item #949871	\$76.62	
	Mono test item #951314	\$99.68	
	Terbinafine cream item #793775	\$30.04	
	Earwax softener drops item #1129811	\$24.66	
	Tussin DM item #1238977	\$22.50	

Allan Hancock College

Warrant Register

Check Dates from 5/1/2025 to 5/31/2025

Bank Code: CT

Vendor Name	Description	Amount	Warrant
McKesson Medical Surgical Inc	miconazole cream item #1244992	\$11.22	
	Table Paper item #863413	\$83.73	
	Truemetrix test strips item #960298	\$24.92	
	Scapel 15 item # 1029066	\$21.23	
	Cold pack covers item #898582	\$19.22	
		\$1,093.11	CT 25057305
Mission Linen Supply	Uniform Services and Towels, 7-01-24 thru 6-30-25	\$23.19	
	Uniform Services and Towels, 7-01-24 thru 6-30-25	\$27.53	
		\$50.72	CT 25057306
Modern Symphony Entertainment	DJ services for Grad Central on May 23, 2025	\$700.00	
			\$700.00
Monterey Peninsula College	Cost-Reimbursement Subaward Agreement for	\$3,562.33	
			\$3,562.33
Moorpark College	Cost-reimbursement Subaward Agreement for	\$35,133.20	
			\$35,133.20
Christina Nunez	Reimbursement for Light Refreshments for SPOL/PLO	\$61.20	
			\$61.20
ODP Business Solutions LLC	OFFICE-OPERATIONAL SUPPLIES, 7-15-24 TO 5-30-25	\$538.61	
	Operational Supplies	\$9.73	
	Operational Supplies	\$14.89	
	Operational Supplies	\$222.21	
	OFFICE/OPERATIONAL SUPPLIES: 7/29/24 - 5/31/25	\$83.09	
	Office Operational Supplies 9-24-24 to 5-30-25	\$578.32	
	Basic Needs Center Supplies, 7/01/2024 - 5/30/2025	(\$114.69)	
	Basic Needs Center Supplies, 7/01/2024 - 5/30/2025	(\$114.69)	
	Office/Operational Supplies,	\$77.58	
	Operational Supplies for Student Activities Dept,	\$25.08	
	Instructional Supplies, 1/31/25 to 5/30/25	\$16.95	
	Office Supplies for NextUp Office, 4/16/25-5/30/25	\$269.34	
			\$1,606.42
Old Town Shirt Factory	ASBG Stoles BIGE- CadCut Heat, Royal, Left side.	\$54.38	
	ASBG Stoles BIGE- CadCut Heat, Royal, Right side.	\$43.50	
		\$97.88	CT 25057312
Oracle America Inc	Oracle Linux Basic Support: 8/21/24 - 8/20/25,	\$623.75	
	Oracle Linux Premier Support: 8/21/24 - 8/20/25,	\$3,497.50	
		\$4,121.25	CT 25057313
Sandra Orozco	Reimbursement for food and supplies for ECS	\$23.94	
	Reimbursement for food and supplies for ECS	\$21.39	
		\$45.33	CT 25057314
Otter.ai, Inc	Otter Business, 3/07/25 - 3/06/26.	\$10,000.00	
	Premier Support, 3/07/25 - 3/06/26.	\$1,000.00	
		\$11,000.00	CT 25057315
Paradise Services	Annual Testing - Public Safety-LVC Gas Tank	\$350.00	

Allan Hancock College

Warrant Register

Check Dates from 5/1/2025 to 5/31/2025

Bank Code: CT

Vendor Name	Description	Amount	Warrant
Paradise Services	Parts-Nitrogen	\$48.94	
	Fuel Surcharge	\$13.99	
		\$412.93	CT 25057316
Patterson Veterinary Supply Inc	Instructional Supplies, 9-19-24 - 5-30-25	\$138.90	
		\$138.90	CT 25057317
PCPA	INSURANCE CLAIM 649015 SETTLEMENT	\$27,750.00	
		\$27,750.00	CT 25057318
Point Of Action	Nike Therma FIT Pocket Full-Zip Hoodie, Part #	\$1,626.53	
	Nike Therma FIT Pocket Full-Zip Hoodie, Part #	\$632.54	
	Set up	\$14.80	
	Set up	\$0.03	
		\$2,273.90	CT 25057319
Portable Johns, Inc.	Rental-Servicing Portable Toilets and Hand Washing	\$747.77	
		\$747.77	CT 25057320
PPG Architectural Finishes Inc	Supplies per Invoice 812320005571	\$46.31	
	Eco Fee	\$0.70	
	Paint per Invoice 812320005621	\$49.30	
	Eco Fee	\$0.71	
		\$97.02	CT 25057321
ProCare Janitorial Supply, Inc.	Supplies per Invoice 182541	\$6,517.46	
	Expo Low Odor Dry-Erase Marker, Black, 12-Box	\$2,146.73	
	Expo White Board Erasers, SAN 81505	\$2,656.76	
	Semperguard Glove, XL per Invoice 182516-1	\$42.73	
	Semperguard Glove, Large per Invoice 182516	\$42.73	
		\$11,406.41	CT 25057322
Proquest Llc	BOOKS FOR LIBRARY: 3/18/25 - 5/30/25	\$62.82	
	BOOKS FOR LIBRARY: 3/18/25 - 5/30/25	\$122.03	
	BOOKS FOR LIBRARY: 3/18/25 - 5/30/25	\$15.72	
		\$200.57	CT 25057323
Quinn Company	Rental of (2) Solar/Hybrid Light Towers 380-4003,	\$2,881.78	
	Env. Recycling Fee	\$62.75	
	Delivery Fee	\$326.25	
	\$3,270.78	CT 25057324	
Maria Ramirez-Garibay	Reimbursement for supplies purchased for SkillsUSA	\$55.98	
	Reimbursement for supplies purchased for SkillsUSA	\$69.90	
		\$125.88	CT 25057325
Resources for Infant Educarers	35th Annual RIE Conference - Hybrid Invoice number	\$345.00	
		\$345.00	CT 25057326
Amy Rice	Reimbursement for RVT License Fee, 5/14/25.	\$225.00	
		\$225.00	CT 25057327
Sergio Ruiz	Photography of 2025 Transfer Stars Celebration	\$350.00	

Allan Hancock College

Warrant Register

Check Dates from 5/1/2025 to 5/31/2025

Bank Code: CT

Vendor Name	Description	Amount	Warrant
		\$350.00	CT 25057328
Safety-Kleen Systems, Inc	30G Parts Washer (LG)-Aqueous	\$292.58	
	Gastec Aqueous PW Sample Tube	\$6.53	
	Chemistry Fee	\$27.80	
	Recovery Fee	\$43.37	
	30G Parts Washer Serial#21126694, Invoice #	\$292.58	
	30G Parts Washer Serial#21126466	\$292.58	
	Gastec Aqueous PW Sample Tube Part#8863	\$13.05	
	Chemistry Fee Part#100005	\$55.59	
	Recovery Fee	\$86.74	
	E-Manifest Fee	\$27.00	
	Used Oil Recovery Fee	\$87.00	
	Used Oil - Automotive	\$110.50	
		\$1,335.32	CT 25057329
San Luis Obispo County Community College District	Cost-Reimbursement Subaward Agreement for	\$16,456.59	
		\$16,456.59	CT 25057330
Santa Barbara City College	Cost-Reimbursement Subaward Agreement for	\$24,680.83	
		\$24,680.83	CT 25057331
Save Mart Supermarkets	Food Supplies for Children's Center:	\$246.59	
	Food Supplies for Children's Center:	\$322.68	
	Food Supplies for Children's Center:	\$249.48	
	Food Supplies for Children's Center:	\$357.13	
		\$1,175.88	CT 25057332
Shop Pop Displays Inc.	Matte White Laminate Pedestal 18"L x 18"W x36"H	\$2,906.89	
	Freight-Commercial Dock to Dock	\$534.01	
		\$3,440.90	CT 25057333
Smart & Final	Tutorial Center Snacks VALID 5-2-25 TO 5-31-25	\$162.93	
	Food Items: 7/02/24 - 6/30/25	\$17.22	
	Food and Beverage Purchases for Men's Support	\$395.42	
	Food/Drink Supplies for MESA/STEM Events: 3/18/25	\$362.40	
	Food and Beverage Purchases for Men's Support	\$103.32	
	Food for various outreach events and activities.	\$234.44	
	Supplies for various outreach events and	\$195.77	
	Food and Beverage Purchases for Men's Support	\$131.21	
	Food for various outreach events and activities.	\$39.96	
	Supplies for various outreach events and	\$18.28	
	Snacks and Food Supplies for UTC Workshops and	\$157.64	
	Chemistry Lab Supplies: 7/01/24 - 5/30/25	\$92.40	
	Food for various outreach events and activities.	\$33.56	
	Supplies for various outreach events and	\$10.85	
	Food Items: 7/02/24 - 6/30/25	\$128.22	
	Food for Student Lunch Locker- Santa Maria,	\$174.06	
	Food for Student Lunch Locker- Santa Maria,	\$149.50	
	Tutorial Center Snacks VALID 5-2-25 TO 5-31-25	\$166.84	
		\$2,574.02	CT 25057334

13-55
Allan Hancock College
Warrant Register
Check Dates from 5/1/2025 to 5/31/2025
Bank Code: CT

Vendor Name	Description	Amount	Warrant
Smart & Final	Food for Children's Center 5-01-25 to 6-30-25	\$192.63	CT 25057335
	Food for Children's Center 5-01-25 to 6-30-25	\$227.66	
	Food for Children's Center 5-01-25 to 6-30-25	\$337.35	
	Food for Children's Center 5-01-25 to 6-30-25	\$278.95	
		\$1,036.59	
	Food for Culinary Arts, 3-28-25 to 6-28-25	\$337.70	
	Food for Culinary Arts, 3-28-25 to 6-28-25	\$26.99	
	Food for Culinary Arts, 3-28-25 to 6-28-25	\$51.29	
		\$415.98	
		CT 25057336	
Smith Pipe & Supply Inc	Supplies for AHC Grounds Dept. - 1.28.2025 thru	\$146.02	CT 25057337
	Supplies for AHC Grounds Dept. - 1.28.2025 thru	\$162.34	
	Supplies for AHC Grounds Dept. - 1.28.2025 thru	\$1.08	
	Supplies for AHC Grounds Dept. - 1.28.2025 thru	\$475.32	
	Supplies for AHC Grounds Dept. - 1.28.2025 thru	\$247.11	
		\$1,031.87	
Richard Soto	Reimbursement for supplies, 5/06/25.	\$22.83	CT 25057338
		\$22.83	
Source Graphics	Office Supplies - Wide format Paper and Media	\$697.63	CT 25057339
		\$697.63	
Sousa Tire Service	Tires, Toyo Open Country HT II per Invoice 82865	\$450.23	CT 25057340
	State Tax Recycle Fee	\$3.50	
	Tire Disposal Fee	\$40.50	
		\$494.23	
Sticks Media LLC	15-second News Sponsorship Message Summer Fall Reg	\$825.00	CT 25057341
		\$825.00	
Strata Information Group	Banner DBA & ODS Support Services per SOW13818-	\$3,330.00	CT 25057342
	Degree Works Consulting Support for FY 2024-2025	\$2,790.00	
	Consulting Financial Aid- Banner Tech Support	\$5,175.00	
		\$11,295.00	
Superior Pool Products LLC	Chlorine DPD Tablet, PAL-47-826	\$57.89	CT 25057343
	Alkalinity Tablet Reagent, PAL47-827	\$149.13	
	PH Phenol Red Tablet Reagent, PAL-47-825	\$49.72	
	Calcium Hardness Tablet, PAL-47-828	\$119.93	
	Freight charges	\$10.09	
		\$386.76	
Teachstone Inc	Observer Recertification - Quote Number 00003758	\$135.00	CT 25057344
		\$135.00	
The Lompoc Vision	5x5 Display Ad 2025 Summer Fall Registration	\$280.00	CT 25057345
		\$280.00	
Tri County Office Furniture	Hon 24" Cable Management Tray, Black. Proposal #	\$456.11	
	Hon Motivate Table, 24x36, 3" Round Grommet,	\$576.43	
	Hon Motivate Table, 24x60, 3" Round Grommet,	\$632.29	
	Hon Motivate Table, 24x96, 3" Round Grommet,	\$2,465.18	
	Field Installable Grommet, Black.	\$73.14	

13-56
Allan Hancock College
Warrant Register
Check Dates from 5/1/2025 to 5/31/2025
Bank Code: CT

Vendor Name	Description	Amount	Warrant
Tri County Office Furniture	Modular Systems Delivery	\$1,082.06	
		\$5,285.21	CT 25057346
Trojan Petroleum, Inc	Unleaded Gas per Invoice 334851	\$9,312.60	
		\$9,312.60	CT 25057347
Uline Inc	Supplies for Basic Needs Pantry and Center,	\$237.68	
	Supplies for Basic Needs Pantry and Center,	\$406.84	
	Supplies for Basic Needs Pantry and Center,	\$646.09	
		\$1,290.61	CT 25057348
United Health Care Insurance Co	RETIREE AARP INSURANCE PREMIUMS JUN 2025	\$380.62	
		\$380.62	CT 25057349
United Refrigeration Inc	Ambro Precision Torch F/ Oxyset Product #181161	\$209.91	
	Ambro Oxygen Cylinder 1595 PSI Product #1811323	\$70.03	
	Mapp 14.10oz Cylinder Mapp Product #MT1	\$33.01	
	Ambro Oxyset Mobile Brazing System Product #181168	\$702.53	
		\$1,015.48	CT 25057350
Urbane Cafe	Catering for Wellness Advisory Meeting, 5/13/25.	\$465.45	
	Delivery Fee	\$25.00	
	Gratuity	\$98.09	
	Food Purchase for End-of-Semester Tutor	\$60.90	
		\$649.44	CT 25057351
Valley Glass & Mirror Co	Remove and Replace Broken Awning Operator Arm,	\$234.94	
		\$234.94	CT 25057352
Ventura County Community College District	Cost-Reimbursement Subaward Agreement for	\$19,906.49	
Oxnard College	Cost-reimbursement Subaward Agreement for	\$2,608.32	
		\$22,514.81	CT 25057353
Ward's Science Inc	Science Lab Supplies July 1, 2024-May 30, 2025	\$965.96	
		\$965.96	CT 25057354
Yankee Book Peddler Inc	LVC LRC Lola Dority book funds 4.16.25 - 5.30.25	\$26.27	
	LVC Library books 3.11.25 - 5.30.25	\$513.55	
		\$539.82	CT 25057355
Thomas Cline	Manual Refund Submitted	\$164.00	
		\$164.00	CT 25057356
Hope Goodall	Manual Refund Submitted	\$1,156.00	
		\$1,156.00	CT 25057357
Felipe Guevara Leal	Manual Refund Submitted	\$500.00	
		\$500.00	CT 25057358
Ivan Hernandez-Barrueta	Manual Refund Submitted	\$1,309.00	
		\$1,309.00	CT 25057359
Janeth Ojeda Herrera	Manual Refund Submitted	\$1,063.00	

13-57
Allan Hancock College
Warrant Register
 Check Dates from 5/1/2025 to 5/31/2025
 Bank Code: CT

Vendor Name	Description	Amount	Warrant
		\$1,063.00	CT 25057360
Remelyn Perez	Manual Refund Submitted	\$462.00	
		\$462.00	CT 25057361
Heidi Rodriguez	Manual Refund Submitted	\$1,821.00	
	Manual Refund Submitted	\$1,387.00	
		\$3,208.00	CT 25057362
Arianna Ruiz	Manual Refund Submitted	\$2.00	
		\$2.00	CT 25057363
Irene Segura	Manual Refund Submitted	\$500.00	
		\$500.00	CT 25057364
Dallas Tovar	Manual Refund Submitted	\$12.00	
		\$12.00	CT 25057365
Melissa Ventura	Manual Refund Submitted	\$47.80	
		\$47.80	CT 25057366
Abasa-Nyarko, Charles	Interviewee Reimbursement 5.25	\$600.00	
		\$600.00	CT 25057367
Donna Beal	Central Coast K16 Conference	\$80.78	
		\$80.78	CT 25057368
Michael Bernal	OPEN MILEAGE 24-25	\$618.80	
		\$618.80	CT 25057369
BHOV Santa Cruz LLC	CCCSAA Conf Hotel Teniente, Yvonne	\$738.21	
	CCCSAA Conf Hotel Robb, Stephanie	\$731.47	
		\$1,469.68	CT 25057370
Carmen Bissin	Open Mileage 5.6.25	\$78.75	
		\$78.75	CT 25057371
Robert Bryant	OPEN MILEAGE FY24	\$175.70	
		\$175.70	CT 25057372
Martin Castillo	Additional Mileage April	\$11.06	
		\$11.06	CT 25057373
Comcast Cable	Comcast Monthly Internet Costs: 7/01/24 - 6/30/25	\$301.04	
		\$301.04	CT 25057374
	Comcast Monthly Internet Costs: 7/01/24 - 6/30/25	\$254.65	
		\$254.65	CT 25057375
Michael Cottam	CA Fire Mechanic Academy Training	\$2,418.55	
		\$2,418.55	CT 25057376
Daugherty, Devin	Interview Reimbursement 5.15.25	\$158.20	
		\$158.20	CT 25057377
Alejandra Enciso	Open Mileage 5.20.25	\$14.00	

13-58
Allan Hancock College
Warrant Register
Check Dates from 5/1/2025 to 5/31/2025
Bank Code: CT

Vendor Name	Description	Amount	Warrant
		\$14.00	CT 25057378
Grijalva, Nicholas P.	ADAS Seminar	\$505.49	
		\$505.49	CT 25057379
Lerma, Michael	Interviewee Reimbursement	\$600.00	
		\$600.00	CT 25057380
Suzanne Lewy	Open Mileage 5.20.25	\$13.44	
		\$13.44	CT 25057381
Alexa Martinez	Addtl April Mileage	\$29.96	
		\$29.96	CT 25057382
Crystal Neal	Open Mileage 10/24-5/25	\$20.16	
		\$20.16	CT 25057383
Kenneth Ostini	Open Mileage 5.20.25	\$117.60	
		\$117.60	CT 25057384
Greg Pensa	Open Mileage 5.20.25	\$161.00	
		\$161.00	CT 25057385
Perez, David	INTERVIEW REIMBURSEMENT 5.2025	\$600.00	
		\$600.00	CT 25057386
Maria Ramirez-Garibay	Skills USA Conf Per Diem 6.2025	\$9,630.00	
		\$9,630.00	CT 25057387
Robertson, Jessica	Interview Reimbursement 5.25	\$304.00	
		\$304.00	CT 25057388
Lucerito Salgado Olivera	JAN-APR25 OPEN MILEAGE	\$25.06	
		\$25.06	CT 25057389
Schroeter, Robert	Native Bee Training 3.2025	\$1,120.10	
		\$1,120.10	CT 25057390
Megan Selby	Cal Poly Pomona Student Field Trip	\$581.50	
		\$581.50	CT 25057391
Ora Shrecengost	Open Mileage 5.20.25	\$9.38	
		\$9.38	CT 25057392
Signia by Hilton Atlanta Georgia	Hotel for Skills USA Conf 6.2025	\$22,832.88	
		\$22,832.88	CT 25057393
Genevieve Siwabessy	5C Meeting Sacramento, CA	\$497.10	
		\$497.10	CT 25057394
Skills Usa California	Skills USA Conference 6.22.25	\$6,300.00	
		\$6,300.00	CT 25057395
Southern California Gas Co	Natural Gas Supply 7/01/2024 - 6/30/2025	\$9,232.91	
	Natural Gas Supply 7/01/2024 - 6/30/2025	\$1,907.18	

Allan Hancock College

Warrant Register

Check Dates from 5/1/2025 to 5/31/2025

Bank Code: CT

Vendor Name	Description	Amount	Warrant
		\$11,140.09	CT 25057396
Southern California Gas Co	Natural Gas Supply 7/01/2024 - 6/30/2025	\$220.59	
	Natural Gas Supply 7/01/2024 - 6/30/2025	\$45.57	
		\$266.16	CT 25057397
AHC - District Trust Fund	Payroll Deduct 05.30.25 Management Association	\$220.00	
		\$220.00	CT 25057398
AHC Foundation	Payroll Deduct 05.30.25	\$3,085.96	
		\$3,085.96	CT 25057399
All American Screen Printing Inc	Embroidery 12 Black Hats, Invoice #0001787.	\$234.90	
	Embroidery 12 Beanies	\$195.75	
	Embroidery (16) Eddie Bauer	\$1,348.50	
		\$1,779.15	CT 25057400
Amazon	MMAC Instructional Supplies 4/10/2025-5/30/2025	\$405.02	
	Instructional supplies for Engineering courses,	\$9.86	
	Instructional supplies for Engineering courses,	\$208.40	
	Instructional supplies for Engineering courses,	\$444.89	
	Instructional supplies for Engineering courses,	\$206.85	
	Instructional supplies Oct 17, 2024 - May 30, 2025	\$11.12	
	Chemistry Lab Supplies: 7/01/24 - 5/30/25	\$323.86	
	BOOKS FOR LIBRARY, 3/25/25 - 5/30/25	\$54.92	
	24" Prize Wheel - Dual Use Tabletop or Height	\$278.88	
	Shipping & Handling	\$0.00	
	Instructional Supplies, 4/14/25 - 5/30/25	\$743.04	
	OFFICE-OPERATIONAL SUPPLIES FOR LE,	\$460.51	
	OFFICE-OPERATIONAL SUPPLIES FOR LE,	\$40.26	
	Office Operational Supplies from 7/1/24 to 5/30/25	\$67.68	
	Instructional Supplies, 7/01/24 - 5/30/25	\$377.04	
	Office supplies and print shop supplies	\$189.94	
	AB PLC Training Kit HMI Processor	\$4,078.12	
	Office supplies 4/11/2025-5/30/2025	\$26.07	
	Office Supplies, 5/6/25 - 5/30/25	\$16.30	
		\$7,942.76	CT 25057401
American Business Machines	Wide Format Supplies, Staples	\$1,109.25	
		\$1,109.25	CT 25057402
American Fidelity Assurance Co	employee premiums voluntary products May 2025	\$38,933.65	
		\$38,933.65	CT 25057403
	Employee Premiums Flex Spend MAY 2025	\$13,642.63	
		\$13,642.63	CT 25057404
	employee premiums health savings account May 2025	\$8,827.25	
		\$8,827.25	CT 25057405
American Industrial Supply	Operational Supplies for Fire Academy	\$332.66	

Allan Hancock College

Warrant Register

Check Dates from 5/1/2025 to 5/31/2025

Bank Code: CT

Vendor Name	Description	Amount	Warrant
		\$332.66	CT 25057406
Aquapulse Chemicals	Hydrochloric Acid 15% per Invoice 2505006000	\$649.24	
	Energy-Fuel Charge	\$47.76	
	Aqua-Chlor 12.5% per Invoice 2505006014	\$2,009.70	
	Energy-Fuel Charge	\$147.84	
		\$2,854.54	CT 25057407
Barbara Armstrong	Independent Service Agreement to provide	\$7,465.50	
		\$7,465.50	CT 25057408
Anna Arrowsmith	Reimbursement for food expenses for noncredit HOEC	\$235.73	
		\$235.73	CT 25057409
Assoc CA Community College Admin	Payroll Deduction 05.30.25	\$109.89	
		\$109.89	CT 25057410
Aztec Software, LLC	GED Ready The Official Practice Test, Product ID	\$1,215.00	
		\$1,215.00	CT 25057411
B&H Photo Video	SENNHEISER MKE 600 SHOTGUN MICROPHONE/REG	\$919.47	
	Photo Instructional Supplies 4/14/2025-5/30/2025	\$146.64	
	Photo Instructional Supplies 4/14/2025-5/30/2025	\$100.26	
		\$1,166.37	CT 25057412
Bremer Auto Parts	Supplies/parts for LE vehicles: 7/02/24 - 5/30/25.	\$9.27	
	Supplies/parts for LE vehicles: 7/02/24 - 5/30/25.	\$37.81	
	Operational Supplies for Fire Academy	\$235.61	
		\$282.69	CT 25057413
C.S.E.A. Chapter 251 Dues - AHC	Payroll Deduction 05.30.25	\$495.00	
		\$495.00	CT 25057414
C.S.E.A. Victory Club	Payroll Deduction 05.30.25	\$172.50	
		\$172.50	CT 25057415
CA School Employees Association	Payroll Deduction 05.30.25	\$9,327.19	
		\$9,327.19	CT 25057416
Cal State Auto Parts	Oil per Invoice 330383	(\$97.61)	
	Sensor ASM, HTD OXY per Invoice 329787	\$90.02	
	Oil per Invoice 330383	\$97.61	
	Supplies per Invoice 331699	\$50.25	
		\$140.27	CT 25057417
California Electric Supply	LED Light bulbs	\$739.50	
		\$739.50	CT 25057418
CDW Government Inc	Poly Voyager 4245 Office Headset, CDW #7597465.	\$212.39	
		\$212.39	CT 25057419
City of Guadalupe	Lock in, Deposit, and Rental for the Guadalupe	\$2,400.00	

13-61

Allan Hancock College

Warrant Register

Check Dates from 5/1/2025 to 5/31/2025

Bank Code: CT

Vendor Name	Description	Amount	Warrant
		\$2,400.00	CT 25057420
City of Santa Maria Alarm Program	False Alarm Charges, 3-15-25, Invoice #27928.	\$360.00	
		\$360.00	CT 25057421
Coast Clutch & Brake Supply	Supplies per Invoice 185976	\$85.45	
		\$85.45	CT 25057422
Coast Diesel Service	Exhaust Gas Temp Sensor per Invoice 94932	\$247.34	
	Labor Charges-Replaced Sensor and Cleared Code	\$260.00	
	Parts for Truck Driving Program	\$44.03	
	Labor for Truck Driving Program,	\$130.00	
	Labor for Truck Driving Program,	\$379.00	
	Labor for Truck Driving Program,	\$195.00	
	Labor for Truck Driving Program,	\$195.00	
	Labor for Truck Driving Program,	\$195.00	
	Labor for Truck Driving Program,	\$130.00	
	Labor for Truck Driving Program,	\$130.00	
		\$1,905.37	CT 25057423
Culture Food Trailer	Food for Transfer Star Celebration event, 5/16/25.	\$4,485.00	
		\$4,485.00	CT 25057424
Dataprint Corporation	Operational Supplies, 4/23/25 - 5/30/25	\$479.66	
		\$479.66	CT 25057425
Department Of State Hospitals	Instructional Services Agreement for Law	(\$27,020.00)	
	Instructional Services Agreement for Law	\$60,467.50	
		\$33,447.50	CT 25057426
Design Science Inc	MathType for office tools, 5/9/25-5/9/26	\$427.20	
	MathType SaaS, 5/9/25-5/9/26	\$534.00	
		\$961.20	CT 25057427
Miguel Diaz	Reimbursement for tacos for Last Day of PSY 101	\$81.10	
		\$81.10	CT 25057428
Duxbury Systems, Inc	Duxbury Braille Translator for Windows Single-user	\$490.00	
	Duxbury Braille Translator for Windows Single-user	\$1,470.00	
		\$1,960.00	CT 25057429
Vicki Edralin	Balloon arch for photo op	\$750.00	
	33 Mini centerpieces	\$395.00	
		\$1,145.00	CT 25057430
Envoy Plan Services Inc.	Payroll Deduction 05.30.25	\$134,378.75	
		\$134,378.75	CT 25057431
FACCC Fac Assoc CA Comm Colleges	Payroll Deduction 05.30.25	\$239.00	
		\$239.00	CT 25057432
Faculty Association of AHCC	Payroll Deduction 05.30.25	\$9,974.61	
		\$9,974.61	CT 25057433

13-62
Allan Hancock College
Warrant Register
Check Dates from 5/1/2025 to 5/31/2025
Bank Code: CT

Vendor Name	Description	Amount	Warrant
Farm Supply Company	Instructional Supplies, 9/05/24 to 5/30/25	\$623.33	
		\$623.33	CT 25057434
Federal Express Corp	Mailings for Acct #1104-8488	\$9.77	
		\$9.77	CT 25057435
Ferguson Enterprises Inc	Plumbing Supplies - 12.5.2024 - 5.30.2024	\$43.83	
	Plumbing Supplies - 12.5.2024 - 5.30.2024	\$29.97	
	Plumbing Supplies - 12.5.2024 - 5.30.2024	\$105.46	
	Plumbing Supplies - 12.5.2024 - 5.30.2024	\$106.98	
		\$286.24	CT 25057436
Firestone Walker Brewing Company	Venue Rental Fees for Management Association	\$538.75	
	Food, Beverage, Gratuity, and Admin Fees (price	\$2,328.15	
		\$2,866.90	CT 25057437
Flinn Scientific Inc	Chemistry Lab Supplies: 7/01/24 - 5/30/25	\$315.09	
		\$315.09	CT 25057438
Follett Heg - Ahc Bookstore	Book Voucher for NextUp Students, ending 6-30-25	\$126.73	
		\$126.73	CT 25057439
	Rising Scholars Supplies Spring 2025	\$69.93	
	Rising Scholars Supplies Spring 2025	\$69.94	
		\$139.87	CT 25057440
	EOPS Student Supplies for Spring 2025	\$473.72	
		\$473.72	CT 25057441
Foodbank Of Santa Barbara County	Food for Foodshare and Basic Needs Food Pantry for	\$1,053.59	
		\$1,053.59	CT 25057442
Franchise Tax Board	Payroll Deduction 05.30.25	\$371.91	
		\$371.91	CT 25057443
	Payroll Deduction 05.30.25	\$81.89	
		\$81.89	CT 25057444
	Payroll Deduction 05.30.25	\$643.00	
		\$643.00	CT 25057445
Freedom Scientific BLV Group, LLC	SMA Renewal for Fusion NEL-5 User v2026 (to	\$1,700.00	
		\$1,700.00	CT 25057446
Amy Gisclon	Reimbursement for Food, Supplies, Beverages, and	\$206.11	
		\$206.11	CT 25057447
Grant House Sewing Machines	Sunstar SB400- Professional boiler iron system.	\$651.41	
	Sunstar SIT-250- Professional vacuum ironing	\$1,249.54	
	Janome AT2000D- 4 Thread air thread serger	\$1,195.16	
	Janome CP3000P- Top and bottom coverstitch	\$1,195.16	
	Consew 75T- Portable professional blindstitcher	\$325.16	
	Consew 7360R-7DD-2- Industrial direct drive single	\$1,412.66	
	Freight	\$450.00	

13-63

Allan Hancock College

Warrant Register

Check Dates from 5/1/2025 to 5/31/2025

Bank Code: CT

Vendor Name	Description	Amount	Warrant
		\$6,479.09	CT 25057448
Weston Guerra	Reimbursement for large fingerprint padlock,	\$50.85	
		\$50.85	CT 25057449
H&E Equipment Services Inc	Light Tower Manual Solar LED Tower	\$3,262.50	
	Property Tax Recovery Fee	\$24.47	
	Environmental Rental Fee	\$81.56	
		\$3,368.53	CT 25057450
Marc Hammill	Reimbursement for Wet Lab Supplies Required by	\$204.40	
		\$204.40	CT 25057451
Elaine Healy	Reimbursement for food for Tutor Training meeting,	\$75.62	
		\$75.62	CT 25057452
Henry Schein Inc	Tape Zinc-Oxide "M" Tape	\$4,584.79	
	Tape M-Tape, Pink	\$70.25	
	M-Tape Zinc Oxide	\$136.38	
	Tape Zinc-Oxide "M" Tape	\$70.69	
	Tape Zinc-Oxide "M" Tape	\$70.69	
		\$4,932.80	CT 25057453
Home Depot	Chemistry Lab Supplies: 7/01/24 - 5/30/25	\$43.84	
	Instructional Supplies for Fire Academy	\$77.35	
	Supplies per Invoice 7192262	\$307.82	
	Supplies per Invoice 6253862	\$56.16	
		\$485.17	CT 25057454
IRS ACS Support	Payroll Deduction 05.30.25	\$119.61	
		\$119.61	CT 25057455
J B Dewar	Fuel for AHC Community Ed Truck Driving Class,	\$1,965.40	
		\$1,965.40	CT 25057456
Kaplan Early Learning Co	Supplies for Children's Center per quote #545780	\$127.77	
	Supplies for Children's Center per quote #545780	\$77.02	
	Supplies for Children's Center per quote #545780	\$268.47	
		\$473.26	CT 25057457
Kekas	Food for Transfer Star Celebration event, 5/16/25.	\$4,524.00	
		\$4,524.00	CT 25057458
Lowes	ART Instructional Supplies 11/4/2024-5/30/2025	\$86.13	
	Instructional Supplies for Art 5/6/25-5/30/2025	\$162.89	
	Instructional Supplies for Art 5/6/25-5/30/2025	\$354.26	
	Instructional Supplies for Art 5/6/25-5/30/2025	\$20.62	
		\$623.90	CT 25057459
Kristen Marshall	PAYROLL DEDUCTION 05/30/2025	\$1,600.00	
		\$1,600.00	CT 25057460
Mathpix Inc	Mathpix Snip Organization - 2 seats	\$99.90	
		\$99.90	CT 25057461
Medco Supply Company	Instructional Supplies per Estimate #ESTMD3151933	\$407.49	

Allan Hancock College

Warrant Register

Check Dates from 5/1/2025 to 5/31/2025

Bank Code: CT

Vendor Name	Description	Amount	Warrant
		\$407.49	CT 25057462
Metropolitan Life Insurance Co	INSURANCE PREMIUMS MAY 2025	\$7,302.39	
		\$7,302.39	CT 25057463
Mission Paving Inc	Paving: Pave along new concrete approximately 80sf	\$2,700.00	
		\$2,700.00	CT 25057464
Marguerite Moreton	Reimbursement for Coffee Purchase for the Study-A	\$77.00	
		\$77.00	CT 25057465
Nicks Telecom	Whelen, Par-46 Supper Replacement LED Spotlight	\$1,044.00	
	Shipping	\$28.71	
		\$1,072.71	CT 25057466
ODP Business Solutions LLC	Operational Supplies for Student Activities Dept,	\$830.10	
	OFFICE/OPERATIONAL SUPPLIES: 7/29/24 - 5/31/25	\$295.28	
	OFFICE SUPPLIE FOR LE, 4/14/25 - 5/30/25	\$54.30	
	OFFICE SUPPLIE FOR LE, 4/14/25 - 5/30/25	\$247.32	
	Office Supplies for "Books for Bulldogs"	\$311.92	
	Instructional Supplies Film 4/9/2025 - 5/30/2025	\$595.32	
		\$2,334.24	CT 25057467
Optiv Security Inc	Palo Alto Networks: Subscription Advanced URL	\$26,031.00	
	Palo Alto Networks: Advanced Threat Prevention	\$26,031.00	
	Palo Alto Networks: DNS Security	\$17,353.98	
	Palo Alto Networks: Partner enabled premium	\$7,664.54	
	Palo Alto Networks: Partner enabled premium	\$10,000.00	
		\$87,080.52	CT 25057468
PARS Public Agency Retirement	PAYROLL DEDUCTION 05/30/2025	\$8,226.04	
		\$8,226.04	CT 25057469
Part Time Faculty AHC - Member	PAYROLL DEDUCTION 05/30/2025	\$12,023.81	
		\$12,023.81	CT 25057470
Andria Perdue-Keiser	Reimbursement for food for ELDN PD May 16, 2025.	\$572.86	
		\$572.86	CT 25057471
Patricia Prado-Rios	Reimbursement for Coffee Purchase for Study-A-Thon	\$248.00	
		\$248.00	CT 25057472
Premium Quality Lighting	Lights -LED 72W/50K, Item #92123	\$1,908.95	
	LED 16WT19/50K/360/CL120-277V/MED	\$957.87	
	LED 4FT Tone-Select 25WT5/35-40-50K/TYPE B/DE/	\$1,033.56	
		\$3,900.38	CT 25057473
Proquest Llc	BOOKS FOR LIBRARY: 3/18/25 - 5/30/25	\$55.01	
		\$55.01	CT 25057474
Gregory Riley	Provide accompaniment services for voice and	\$1,500.00	
		\$1,500.00	CT 25057475
Santa Barbara County Sheriff	PAYROLL DEDUCTION 05/30/2025	\$379.47	

13-65
Allan Hancock College
Warrant Register
Check Dates from 5/1/2025 to 5/31/2025
Bank Code: CT

Vendor Name	Description	Amount	Warrant
		\$379.47	CT 25057476
Santa Barbara County Sheriff's Office	PAYROLL DEDUCTION 05/30/2025	\$960.53	
		\$960.53	CT 25057477
Santa Maria Sun LLC	Digital Companion Ad to run on santamariasun.com	\$45.00	
		\$45.00	CT 25057478
Source Graphics	Office Supplies - Wide format Paper and Media	\$1,280.80	
		\$1,280.80	CT 25057479
Sousa Tire Service	Tire recycling 12-16-24 to 5-30-25	\$45.00	
		\$45.00	CT 25057480
Sport & Cycle Team Athletics Inc	UA M's Black Armour Fleece Storm Full Zip, Item #	\$1,369.93	
	UA Men's Pants, Item #1379587-001	\$1,108.92	
	Shipping	\$125.68	
	UA Ms Sublimated Training Compression Shirt, Item	\$4,240.16	
	Shipping	\$167.14	
		\$7,011.83	CT 25057481
Taqueria La Coqueta	Dinner Purchase for Aim to Dream and Puente	\$682.84	
		\$682.84	CT 25057482
Texas Life Insurance Co.	INSURANCE PREMIUMS MAY 2025	\$13,895.26	
		\$13,895.26	CT 25057483
The Landsby	Management Assoc. Retreat Lunches June 4-5	\$5,374.51	
	Tax on Mission and Copenhagen rms deposit pd 5.14	\$87.50	
		\$5,462.01	CT 25057484
Traffic Safety Store	42"Orange Arrow-Top Tube with 8 lb. base, Item #	\$554.63	
	Shipping	\$495.23	
		\$1,049.86	CT 25057485
Trojan Petroleum, Inc	Diesel Gas per Invoice 334888	\$1,324.25	
		\$1,324.25	CT 25057486
United Refrigeration Inc	HVAC Supplies, 07-01-24 thru 05-31-25	\$144.43	
	HVAC Supplies, 07-01-24 thru 05-31-25	\$147.75	
	HVAC Supplies, 07-01-24 thru 05-31-25	\$331.01	
		\$623.19	CT 25057487
United Way of the Central Coast	PAYROLL DEDUCTION 05/30/2025	\$30.00	
		\$30.00	CT 25057488
Urbane Cafe	Lunch Purchase for Noncredit Student Success and	\$150.08	
	Delivery Fee	\$25.00	
	Lunch for University Transfer Center	\$371.06	
		\$546.14	CT 25057489
Valley Glass & Mirror Co	All labor and materials to remove and replace	\$1,086.51	

13-66

Allan Hancock College

Warrant Register

Check Dates from 5/1/2025 to 5/31/2025

Bank Code: CT

Vendor Name	Description	Amount	Warrant
		\$1,086.51	CT 25057490
Ward's Science Inc	Instructional Supplies for BIOL labs Summer '25	\$139.41	
	Instructional Supplies for BIOL labs Summer '25	\$48.26	
		\$187.67	CT 25057491
Wex Bank	Gas Credit Card Purchases, 03-01-25 thru 6-30-25	\$399.51	
		\$399.51	CT 25057492
Yankee Book Peddler Inc	BOOKS FOR LIBRARY	\$622.43	
	BOOKS FOR LIBRARY, 3/18/25 - 5/30/25	\$582.10	
		\$1,204.53	CT 25057493

Warrant Register

Check Dates from 5/1/2025 to 5/31/2025
Bank Code: CT

Fund and Reversal Summary

Totals By Fund:

Total for General Fund 9410	\$3,619,556.53
Total for Bond Interest & Redemption Fund 9421	\$0.00
Total for Child Development Fund 9433	\$51,302.74
Total for Capital Outlay Project Fund 9441	\$963,520.60
Total for General Obligation Bond Fund 9447	\$14,591.62
Total for Dental Self-Insurance Fund 9461	\$65,927.00
Total for Self-Insurance Health Exam Fund 9462	\$0.00
Total for Self-Insurance, Property, & Liability Fund 9463	\$37,750.00
Total for Post-Employment Benefits Fund 9469	\$0.00
Total for Student Body Center Fee Trust Fund 9473	\$0.00

13-68

Allan Hancock College

Warrant Register

Check Dates from 5/1/2025 to 5/31/2025

Bank Code: RC

Vendor Name	Description	Amount	Warrant
Mariachi Alma de Jalisco	Mariachi band to perform at conclusion of 2025	\$2,000.00	
		\$2,000.00	RC 40000257

ALLAN HANCOCK JOINT COMMUNITY COLLEGE DISTRICT	
May-25	
ACRONYMS	
19six Architects	Nineteen Six Architects (Formerly PMSM)
13 Stars Media	NO ACRONYM
3AM Technologies LLC	NO ACRONYM
4allpromos	NO ACRONYM
4imprint	NO ACRONYM
AERA	American Engine Rebuilders Association
AHC - Part - Time Faculty Association	Allan Hancock College - Part Time Faculty Association
AHC- District Trust Fund	Allan Hancock College- District Trust Fund
AHC Foundation	Allan Hancock College Foundation
AHC-Auxiliary Programs Corporation	Allan Hancock College - Auxiliary Corporation
B&B Steel & Supply	NO ACRONYM
B&H Photo	NO ACRONYM
BHOV Santa Cruz LLC	Barings Hotel Opportunity Venture Santa Cruz LLC
Bio-Rad Laboratories	NO ACRONYM
BRP Pharmaceuticals	Bryant Ranch Prepack Pharmaceuticals
Cal OES	California Office of Emergency Services
CalSoft	NO ACRONYM
Cal State Auto Parts	NO ACRONYM
CCCSAA	California Community College Student Affairs Association
CDW Government Inc	Computer Discount Warehouse Government Inc
C.S.E.A. Chapter 251 Dues AHC	California School Employees Association Chapter 251 Dues Allan Hancock College
C.S.E.A. Victory Club	California School Employees Association Victory Club
Column Software PBC	Column Software Public Benefit Corporation
DMQ Catering	Doug Maria Quintana Catering
EKC Enterprises Inc	NO ACRONYM
FACCC	Faculty Association of California Community Colleges
Faculty Association of AHCC	Faculty Association of Allan Hancock Community College
FasTrak	NO ACRONYM
FOLLETT HEG-AHC	Follett Higher Education Group-Allan Hancock College
GMG Medical Solutions	NO ACRONYM
H&E Equipment Services Inc	Head & Engquist
International E-Z Up Inc	International Easy Up Inc
IRS ACS Support	Internal Revenue Service Automated Collection System Support
J B Dewar	NO ACRONYM
J. J. Keller and Associates Inc	John J Keller and Associates Incorporated
JPlusJ Photography	Josh Plus Jenny Photography
LN Curtis & Sons	NO ACRONYM
MAACO Auto Painting and Bodyworks	Martino Anthony A Company
M&M Restaurant Supply	NO ACRONYM
ODP Business Solutions, LLC	Office Depot Business Solutions, LLC
OTM furniture Installations	On The Move furniture Installations
Otter.ai Inc	NO ACRONYM
PARS	Public Agency Retirement System
Part Time Faculty AHC-Member	Part Time Faculty Allan Hancock College Member
PASCO Scientific	Paul Allen Stokstad Company
PCPA	Pacific Conservatory of the Performing Arts
PPG Architectural Finishes	Pittsburgh Paints & Glass Architectural Finishes
SISC III	Self Insured Schools of California
SLO Safe Ride	San Luis Obispo Safe Ride
Splash N Dash	Splash and Dash
VIRTUAL VRI	Virtual Video Remote Interpreting
VTC Enterprises	Vocational Training Center Enterprises
WEX Bank	Wright Express Financial Services Corp

To: Board of Trustees	Date: July 15, 2025
From: Superintendent/President	
Subject: Approval of Employee Personnel Actions	Item Number: 8.B.
Institutional Goal: Accreditation Standard III	Enclosures: Page 1 of 6

BACKGROUND

In an effort to condense and streamline the information provided to the board of trustees and to eliminate the use of pronouns, the following personnel actions in the subsequent Excel document are recommended:

FISCAL IMPACT

The fiscal impact is included in the following pages.

RECOMMENDATION

Staff recommends the board of trustees approve the following personnel actions as presented.

Administrator Initiating Item: Ruben Ramirez	Final Disposition:
---	--------------------

15- Revised
July 15, 2025
Employee Personnel
Actions

Faculty - Tenure Track							
Special Note: New appointments are contingent upon successful completion of pre-employment requirements. Faculty employed under Ed Code 87470.							
Name	Assignment	Department or Division	Effective Date	Column and Step	Months	Reason/ Comment	
1	Serrano, Danya	assistant professor, psychology	08/12/25	V-6	10-FT	Name selection that was pending in June	
2	Thorpe, Monica	professor, early childhood studies	08/12/25	II-5	10-FT	Name selection that was pending in June	
Fiscal Impact 2025-2026 Fiscal Year							
1	unrestricted general fund					\$	140,344.00
2	unrestricted general fund					\$	120,186.00

Appointment of Interim Management Employee(s)						
Special Note: New appointments are contingent upon successful completion of pre-employment requirements.						
Name	Assignment	Department or Division	Effective Dates	Salary	Reason/Comment	
1	Millard, David	acting chief of police	06/15/25-06/30/25	10-A	Replace Cathy Farley	
2	Millard, David	acting chief of police	07/01/25-08/29/25	10-A	Replace Cathy Farley	
Fiscal Impact 2024-2025 Fiscal Year						
1	unrestricted general fund				\$	10,844.00
2	unrestricted general fund				\$	43,476.00

Classified Staff - Appointments, Promotions and Transfers							
Name	Action	Assignment	Department or Division	Effective Date	Salary	Months and FTE	Reason/Comment
1	Lynn, Nathaniel	appointment	audio visual services coordinator	Information Technology Services	07/16/25	30-A 12-FT	Replace Al Garcia
2	Rodriguez Gallardo, Yessenia	appointment	campus safety officer	Campus Police	07/16/25	23-C 12-FT	Replace Adam Pucciarelli
3	Shaffer, Melissa	appointment	instructional assistant automotive technology	Industrial Technology	07/16/25	24-A 9-PT	Replace Tim Muscio
Fiscal Impact 2024-2025 Fiscal Year							
1	unrestricted general fund					\$	104,138.00
2	unrestricted general fund					\$	95,846.00
3	unrestricted general fund					\$	51,911.00

Classified Staff - Change of Status							
Name	Assignment	Department or Division	Effective Date	From	To	Reason/Comment	
1	Rojo, Julio	instructional assistant, media lab	Fine Arts	01/01/25	10-months	12-months	Per article 9.19.1
Fiscal Impact 2025-2026 Fiscal Year							
1	unrestricted general fund					\$	18,866.00

Classified Staff - Extra Work Assignment							
Regular classified staff members who work less than twelve months each year can be scheduled for an extra work assignment at their request. These assignments are scheduled in accordance with article 9, section 9.19, of the district's agreement with the California School Employees Association Allan Hancock College Chapter #251. The following employees have accepted an assignment, and the following schedule is recommended:							
Name	Title	Department or Division	Employment Period	Maximum Hours	Maximum Days/Weeks	Hourly Salary	
1	Orozco, Sandra	administrative assistant II	Academic Affairs	07/01/25-07/31/25	37	5	\$30.59
Fiscal Impact 2024-2025 Fiscal Year							
1	unrestricted general fund					\$	10,092.00

Classified Staff - Out-of-Class Assignments							
Special Note: Pursuant to Government Code 20480, effective January 1, 2018, employees may be limited to 960 hours of out-of-classification pay in a fiscal year.							
Name	Assignment	Department or Division	Effective Dates	From	To	Reason/Comment	
1	Millard, David	acting chief police	Campus Police	06/15/25-06/30/25	4-C (SS#40)	10-A (SS#30)	Replace Cathy Farley
2	Millard, David	acting chief police	Campus Police	07/01/25-08/29/25	4-C (SS#40)	10-A (SS#30)	Replace Cathy Farley
Fiscal Impact 2024-2025 and 2025-2026 Fiscal Years							
1	unrestricted general fund					\$	10,844.00
2	unrestricted general fund					\$	43,476.00

Short-Term/On-Call, Substitutes, Professional Experts						
Special Note: The college hires short-term/on-call employees, substitutes, and professional experts exempt from classified service per Education Code Section 88003. The following appointments are contingent upon availability of funding and the ending date could change based on district need.						
** Important Notice: New employees are not to begin working until clearance has been confirmed from the Human Resources office.						
Name	Action	Position Title	Dates	Hourly	Duties/Responsibilities	
1	Anaya, Emmanuel	substitute	mail clerk/courier	07/01/25-06/30/26	\$ 20.00	On-call substitute for vacation, sick leave, or vacancy
2	Anderson, Craig	short-term	instructional aide V	07/01/25-06/30/26	\$ 26.00	EMS, Fire, Law Enforcement Programs
3	Aubert, Gabriel	short-term	instructional aide VI	07/01/25-06/30/26	\$ 36.00	EMS, Fire, Law Enforcement Programs
4	Bernal, Michael	short-term	food delivery driver	07/01/25-12/19/25	\$ 17.00	During the recruitment of a permanent position
5	Brierly, Amanda	short-term	program assistant III	07/01/25-06/30/26	\$ 20.00	Provide support in the Children's Center, toddler 2 classroom
6	Buelna, Anthony	short-term	program assistant III	07/01/25-12/31/25	\$ 20.00	Support Veteran's Success Center
7	Bull, Brian	short-term	instructional aide IV	07/01/25-06/30/26	\$ 24.00	EMS, Fire, Law Enforcement Programs
8	Burch, William	short-term	instructional aide IV	07/01/25-06/30/26	\$ 24.00	EMS, Fire, Law Enforcement Programs
9	Carpenter, Cole	short-term	instructional aide IV	07/01/25-06/30/26	\$ 24.00	EMS, Fire, Law Enforcement Programs
10	Culliver, Vincent	short-term	instructional aide VI	07/01/25-06/30/26	\$ 36.00	EMS, Fire, Law Enforcement Programs
11	Dart, Ry	short-term	program assistant VI	07/01/25-06/30/26	\$ 24.00	Support Student Engagement Department with various projects
12	Dodd, Connor	short-term	program assistant III	07/01/25-06/30/26	\$ 20.00	Event staff in Athletics Department
13	Doerksen, Adam	short-term	instructional aide IV	07/01/25-06/30/26	\$ 24.00	EMS, Fire, Law Enforcement Programs
14	Dominguez Penalzoza, Amber	short-term	program specialist	07/01/25-07/31/25	\$ 24.00	College Success Coach
15	Espinoza, Maria Del Carmen	short-term	program assistant III	07/01/25-12/19/25	\$ 20.00	Provide support in the Children's Center
16	Fox, Landon	short-term	instructional aide IV	07/01/25-06/30/26	\$ 24.00	EMS, Fire, Law Enforcement Programs
17	Fuerch, Chelsee	short-term	program assistant III	07/01/25-06/30/26	\$ 20.00	Administrative support through summer semester in LAP
18	Galindo, Richard	short-term	instructional aide V	07/01/25-06/30/26	\$ 26.00	EMS, Fire, Law Enforcement Programs
19	Garcia Villanueva, David	short-term	program assistant III	07/01/25-08/31/25	\$ 20.00	Provide administrative support in the CAN-TRIO Program
20	Garcia, Issac	short-term	instructional aide IV	07/01/25-06/30/26	\$ 24.00	EMS, Fire, Law Enforcement Programs
21	Giovanacci, Anthony	short-term	instructional aide IV	07/01/25-06/30/26	\$ 24.00	EMS, Fire, Law Enforcement Programs
22	Gonzalez, Donna	short-term	mental health counselor	07/01/25-06/30/26	\$ 54.00	Provide mental health counseling services for students
23	Grinder, Domitre	short-term	program assistant IV	07/01/25-06/30/26	\$ 24.00	Provide support for Career Center programs
24	Guzman, James	short-term	program assistant IV	07/01/25-06/30/26	\$ 24.00	Provide support for Career Center programs
25	Halucka, Frederick	short-term	instructional aide V	07/01/25-06/30/26	\$ 26.00	EMS, Fire, Law Enforcement Programs
26	Halucka, Frederick	short-term	instructional aide VI	07/01/25-06/30/26	\$ 36.00	EMS, Fire, Law Enforcement Programs

17- Revised
July 15, 2025
Employee Personnel
Actions

Short-Term/On-Call, Substitutes, Professional Experts (Continued)						
27	Hugh, Montgomery	short-term	instructional aide V	07/01/25-06/30/26	\$ 26.00	EMS, Fire, Law Enforcement Programs
28	Hughey, Thomas	short-term	instructional aide V	07/01/25-06/30/26	\$ 26.00	EMS, Fire, Law Enforcement Programs
29	Huicochea, Annette	short-term	program assistant VI	07/01/25-06/30/26	\$ 36.00	Provide extra support serving students during registration periods
30	Iniguez, Angel	short-term	program assistant VI	07/01/25-06/30/26	\$ 36.00	Assist truck driving program and other CDCP noncredit programs
31	Janatsch, Bruce	short-term	instructional aide VI	07/01/25-06/30/26	\$ 36.00	EMS, Fire, Law Enforcement Programs
32	Janatsch, Max	short-term	instructional aide IV	07/01/25-06/30/26	\$ 24.00	EMS, Fire, Law Enforcement Programs
33	Kelly, Tyler	short-term	instructional aide IV	07/01/25-06/30/26	\$ 24.00	EMS, Fire, Law Enforcement Programs
34	Kereakes-Soboslay, Christianne	short-term	instructional aide V	07/01/25-06/30/26	\$ 26.00	EMS, Fire, Law Enforcement Programs
35	Klein, Andrew	short-term	instructional aide V	07/01/25-06/30/26	\$ 26.00	EMS, Fire, Law Enforcement Programs
36	Lagunas Villalobos, Isela	short-term	program assistant V	07/01/25-06/30/26	\$ 26.00	Assist in the noncredit Counseling Department
37	Lucas, Carly	short-term	instructional aide IV	07/01/25-06/30/26	\$ 24.00	EMS, Fire, Law Enforcement Programs
38	Martinez, Charles	short-term	instructional aide VI	07/01/25-06/30/26	\$ 36.00	EMS, Fire, Law Enforcement Programs
39	Martinez, Izabel	short-term	program assistant IV	07/01/25-06/30/26	\$ 24.00	Support essential accounting functions in Auxiliary Accounting
40	McTague, Brennan	short-term	instructional aide VI	07/01/25-06/30/26	\$ 36.00	EMS, Fire, Law Enforcement Programs
41	Medina Bustos, Angel	short-term	program specialist	07/01/25-07/31/25	\$ 24.00	College Success Coach
42	Medina, Marisela	short-term	program assistant VI	07/01/25-06/30/26	\$ 36.00	Provide community outreach & support admissions workshops for Community Education
43	Monreal, Abel	substitute	custodian	07/01/25-06/30/26	\$ 20.00	On-call substitute for vacation, sick leave, or vacancy
44	Montoya, Damaris	short-term	program assistant VI	07/01/25-06/30/26	\$ 36.00	Provide community outreach & support admissions workshops for Community Education
45	Moore, John	short-term	instructional aide VI	07/01/25-06/30/26	\$ 36.00	EMS, Fire, Law Enforcement Programs
46	Murdoch, Timothy	short-term	instructional aide VI	07/01/25-06/30/26	\$ 36.00	EMS, Fire, Law Enforcement Programs
47	Nuno, Jacob	short-term	instructional aide V	07/01/25-06/30/26	\$ 26.00	EMS, Fire, Law Enforcement Programs
48	Palma Guzman, Jeniffer	short-term	program assistant V	06/16/25-08/31/25	\$ 26.00	Support daily operations in the Counseling Department
49	Pino, Josh	short-term	instructional aide VI	07/01/25-06/30/26	\$ 36.00	EMS, Fire, Law Enforcement Programs
50	Pozos Garcia, Baruc	short-term	program specialist	07/01/25-07/31/25	\$ 24.00	College Success Coach
51	Ramos, Anthony	short-term	instructional aide IV	07/01/25-06/30/26	\$ 24.00	EMS, Fire, Law Enforcement Programs
52	Ramos, Luis	short-term	instructional aide IV	07/01/25-06/30/26	\$ 24.00	EMS, Fire, Law Enforcement Programs
53	Rodriguez, Joel	short-term	instructional aide IV	07/01/25-06/30/26	\$ 24.00	EMS, Fire, Law Enforcement Programs
54	Rowan, Jonah	short-term	instructional aide IV	07/01/25-06/30/26	\$ 24.00	EMS, Fire, Law Enforcement Programs
55	Rubalcaba, Amadeo	short-term	program specialist	07/01/25-07/31/25	\$ 24.00	College Success Coach
56	Sanchez, Daisy	short-term	program specialist	07/01/25-07/31/25	\$ 24.00	College Success Coach
57	Santino, Taylor	short-term	instructional aide IV	07/01/25-06/30/26	\$ 24.00	EMS, Fire, Law Enforcement Programs
58	Servin, Susana	short-term	program assistant VI	07/01/25-06/30/26	\$ 36.00	Provide community outreach & support admissions workshops for Community Education
59	Stevens, Nicole	short-term	instructional aide VI	07/01/25-06/30/26	\$ 36.00	EMS, Fire, Law Enforcement Programs
60	Strangfeld, Roberta	short-term	instructional aide VI	07/01/25-06/30/26	\$ 36.00	EMS, Fire, Law Enforcement Programs
61	Taylor, Levi	short-term	instructional aide IV	07/01/25-06/30/26	\$ 24.00	EMS, Fire, Law Enforcement Programs
62	Toole, Jason	short-term	instructional aide V	07/01/25-06/30/26	\$ 26.00	EMS, Fire, Law Enforcement Programs

18-1-Revised
July 15, 2025
Employee Personnel
Actions

Short-Term/On-Call, Substitutes, Professional Experts (Continued)						
63	Valenzuela, Abigail	short-term	program specialist	08/01/25-06/30/26	\$ 24.00	College Success Coach
64	Vassaur, Scott	short-term	instructional aide IV	07/01/25-06/30/26	\$ 24.00	EMS, Fire, Law Enforcement Programs
65	Villanueva, Abraham	substitute	campus security officer	07/01/25-06/30/26	\$ 24.00	On-call substitute for vacation, sick leave, or vacancy
66	Williams, Joseph	substitute	custodian	07/01/25-06/30/26	\$ 20.00	On-call substitute for vacation, sick leave, or vacancy
67	Woody, Enos	short-term	instructional aide VI	07/01/25-06/30/26	\$ 36.00	EMS, Fire, Law Enforcement Programs
68	Zarate, Odaliss	short-term	program assistant V	07/01/25-08/08/25	\$ 26.00	Provide support in the Children's Center Lab School
69	Andrews, Wanda	short-term	model	08/18/25-05/20/26	\$ 26.00	To model and assist in the Fine Arts Department
70	Ayers, Deanna	short-term	program assistant III	07/01/25-06/30/26	\$ 20.00	Event staff in Athletics Department
71	Barger, Thomas	short-term	model	08/18/25-05/20/26	\$ 26.00	To model and assist in the Fine Arts Department
72	Beighley, Shannon	short-term	model	08/18/25-05/20/26	\$ 26.00	To model and assist in the Fine Arts Department
73	Cabrera, Rufina	substitute	custodian	07/01/25-06/30/26	\$ 20.00	On-call substitute for vacation, sick leave, or vacancy
74	Casillas, Ernesto	short-term	program assistant III	07/01/25-06/30/26	\$ 20.00	Event staff in Athletics Department
75	Cathcart, Scott	short-term	program assistant III	07/01/25-06/30/26	\$ 20.00	Event staff in Athletics Department
76	Contreras, Jason	short-term	program assistant III	07/01/25-06/30/26	\$ 20.00	Event staff in Athletics Department
77	Curiel, Sierra	short-term	model	08/18/25-05/20/26	\$ 26.00	To model and assist in the Fine Arts Department
78	Darwin, Elena	short-term	program assistant III	07/01/25-06/30/26	\$ 20.00	Event staff in Athletics Department
79	Diaz, Muriel	short-term	program assistant III	07/01/25-06/30/26	\$ 20.00	Event staff in Athletics Department
80	Einem, Jeremy	short-term	program assistant III	07/01/25-06/30/26	\$ 20.00	Event staff in Athletics Department
81	Endemann, Ben	short-term	program assistant III	07/01/25-06/30/26	\$ 20.00	Event staff in Athletics Department
82	Gastineau, Ashley	short-term	model	08/18/25-05/20/26	\$ 26.00	To model and assist in the Fine Arts Department
83	Goble, Emelia	short-term	program assistant V	07/01/25-07/31/25	\$ 26.00	Assist Counseling Department during registration
84	Griffin, Joanne	short-term	program assistant III	07/01/25-06/30/26	\$ 20.00	Event staff in Athletics Department
85	Guzman, Jacob	short-term	program specialist	07/01/25-07/31/25	\$ 24.00	College Success Coach
86	Hamilton, Nanette	short-term	model	08/18/25-05/20/26	\$ 26.00	To model and assist in the Fine Arts Department
87	Johnson, Chastity	short-term	program assistant III	07/01/25-06/30/26	\$ 20.00	Event staff in Athletics Department
88	Kichler, Buddy	short-term	program assistant III	07/01/25-06/30/26	\$ 20.00	Event staff in Athletics Department
89	Lopez, Elias	short-term	lifeguard	07/01/25-06/30/26	\$ 18.00	For instructional credit/non-credit courses
90	Lopez, Isaiah	short-term	lifeguard	07/01/25-06/30/26	\$ 18.00	For instructional credit/non-credit courses
91	Lutz, Lee	short-term	program assistant III	07/01/25-06/30/26	\$ 20.00	Event staff in Athletics Department
92	McKay, Michael	short-term	lifeguard	07/01/25-06/30/26	\$ 18.00	For instructional credit/non-credit courses
93	Medina Bustos, Angel	short-term	program specialist	07/07/25-08/31/25	\$ 24.00	College Success Coach
94	Montoya, Geraldine	short-term	program specialist	08/01/25-06/30/26	\$ 30.00	College Success Coach
95	Nett, Keith	short-term	model	08/18/25-05/20/26	\$ 26.00	To model and assist in the Fine Arts Department
96	Oliver, Braden	short-term	lifeguard	07/01/25-06/30/26	\$ 18.00	For instructional credit/non-credit courses
97	Olivera, Dalilia	short-term	instructional aide IV	07/01/25-06/30/26	\$ 24.00	EMS, Fire, Law Enforcement Programs
98	Panther, Gary	short-term	program assistant III	07/01/25-06/30/26	\$ 20.00	Support Outreach efforts
99	Parker, Shemarr	short-term	program assistant III	07/01/25-06/30/26	\$ 20.00	Event staff in Athletics Department

18-2- Revised
 July 15, 2025
 Employee Personnel
 Actions

Short-Term/On-Call, Substitutes, Professional Experts (Continued)						
100	Perez Santos, Kathleen	short-term	program specialist	08/01/25-06/30/26	\$ 30.00	College Success Coach
101	Pugh, Nolan	short-term	model	08/18/25-05/20/26	\$ 26.00	To model and assist in the Fine Arts Department
102	Rehder, Hannah	short-term	lifeguard	07/01/25-06/30/26	\$ 18.00	For instructional credit/non-credit courses
103	Russell, Bret	short-term	program assistant III	07/01/25-06/30/26	\$ 20.00	Event staff in Athletics Department
104	Sebastiani, Dominic	short-term	program assistant III	07/01/25-06/30/26	\$ 20.00	Event staff in Athletics Department
105	Silas, Carolyn	short-term	program assistant III	07/01/25-06/30/26	\$ 20.00	Event staff in Athletics Department
106	Snow Robert	short-term	model	08/18/25-05/20/26	\$ 26.00	To model and assist in the Fine Arts Department
107	Terrones, Antionette	short-term	program assistant III	07/01/25-06/30/26	\$ 20.00	Event staff in Athletics Department
108	Thacker, Cynthia	short-term	model	08/18/25-05/20/26	\$ 26.00	To model and assist in the Fine Arts Department
109	Varela, Gilbert	short-term	program assistant III	07/01/25-06/30/26	\$ 20.00	Event staff in Athletics Department
110	Veal, Terry	short-term	program assistant III	07/01/25-06/30/26	\$ 20.00	Event staff in Athletics Department
111	Vela, Marissa	substitute	program assistant VI	07/01/25-09/30/25	\$ 36.00	During the recruitment of a permanent position
112	Verch, Gregory	short-term	program assistant III	07/01/25-06/30/26	\$ 20.00	Event staff in Athletics Department
113	Zepeda, Sandy	short-term	program assistant V	07/01/25-06/30/26	\$ 26.00	Coordination of Apprenticeship Program in Academic Affairs

Coaching Appointments and Stipends					
Special Note: The college reserves the right to cancel any coaching appointment or to reassign the area of service.					
Name	Assignment	Sport	Effective Dates	Stipend	
1	Atencio, Dan	assistant coach	football	08/01/25-11/01/25	\$ 3,000.00
2	Ayers, Deanna	assistant coach	men & women	08/01/25-07/31/26	\$ 13,500.00
3	Banda, Francisco	assistant coach	men's soccer	08/01/25-11/31/25	\$ 4,500.00
4	Baro, Maisen	assistant coach	men's soccer	08/01/25-11/31/25	\$ 5,000.00
5	Barstow, Robert	assistant coach	football	08/01/25-11/01/25	\$ 3,000.00
6	Bernal, Jillian	assistant coach	women's soccer	08/01/25-11/31/25	\$ 4,000.00
7	Cross, Donald	assistant coach	football	01/01/26-04/01/26	\$ 2,500.00
8	Dodd, Connor	assistant coach	women's basketball	06/06/25-06/30/25	\$ 1,000.00
9	Garcia, Elias	assistant coach	football	01/01/26-04/01/26	\$ 1,000.00
10	Garcia, Elias	assistant coach	football	08/01/25-11/01/25	\$ 3,000.00
11	Gomez, Bryan	assistant coach	men's soccer	08/01/25-11/31/25	\$ 4,500.00
12	Heather, George	assistant coach	football	01/01/26-04/01/26	\$ 10,000.00
13	Heather, George	assistant coach	football	08/01/25-11/01/25	\$ 15,000.00
14	Hermann, Edward	assistant coach	football	01/01/26-04/01/26	\$ 3,000.00
15	Parker, Joseph	assistant coach	football	01/01/26-04/01/26	\$ 4,000.00
16	Parker, Joseph	assistant coach	football	08/01/25-11/01/25	\$ 4,000.00
17	Terrones, Antoinette	assistant coach	women's soccer	09/01/25-11/01/25	\$ 500.00
18	Varela, Gilbert	assistant coach	football	08/01/25-11/01/25	\$ 3,000.00
19	Varela, Gilbert	assistant coach	football	01/01/26-04/01/26	\$ 3,000.00
Fiscal Impact 2025-2026 Fiscal Year					
unrestricted general fund					\$ 87,500.00

To: Board of Trustees	Date: July 15, 2025
From: Superintendent/President	
Subject: Approval of Appointment of Academic Management Employee	Item Number: 8.C.
Institutional Goal: Accreditation Standard III	Enclosures: Page 1 of 1

BACKGROUND

The district has conducted first and second-level interviews for the position of dean, Public Safety. The selection of a candidate has been made and is contingent upon pre-employment requirements.

The following administrative appointment is recommended:

Deborah Pirman, dean, Public Safety, full-time, 12 months, range 7-A, management salary schedule 30, effective July 16, 2025. Dr. Pirman replaces Mr. Mitch McCann.

Dr. Pirman received her doctorate in leadership; a postgraduate degree as education specialist in curriculum and instruction supervision from the University of the Cumberlands in Williamsburg, Kentucky; her Master of Arts in English from California Polytechnic University in San Luis Obispo, California; and her Bachelor of Arts in liberal arts with concentration in education and psychology from California Lutheran University in Thousand Oaks, California.

Dr. Pirman has been serving as director of the Lompoc Valley Center and Extended Campus since 2024; as the curriculum specialist from 2023 through 2024; and, English faculty from 2013 through 2023. Dr. Pirman has also served as a professional development specialist, educational leadership consultant, and site administrator.

FISCAL IMPACT

The cost to the unrestricted general fund is approximately \$216,949 for the 2025-26 fiscal year and will be included in the 2025-26 fiscal year budget.

RECOMMENDATION

Staff recommends the board of trustees approve the appointment of dean, Public Safety, as presented.

Administrator Initiating Item: Ruben Ramirez	Final Disposition:
---	--------------------

To: Board of Trustees	Date: July 15, 2025
From: Superintendent/President	
Subject: Approval of Part-time Faculty Appointments, Regular Faculty Overload Assignments and Special Assignments/Stipends	Item Number: 8.D.
Institutional Goal: Accreditation Standard III	Enclosures: Page 1 of 15

BACKGROUND

Credit and noncredit instruction and non-instructional assignments for part-time faculty and overload and special assignments/stipends for regular full-time faculty are recommended for the time periods designated on the attached list, as per the California Education Code, Section 87482.5.

FISCAL IMPACT

Budgeted for the 2024-2025 and 2025-2026 fiscal years.

RECOMMENDATION

Staff recommends the board of trustees approve the attached list of part-time faculty appointments and regular faculty overload and special assignments/stipends.

Administrator Initiating Item: Robert Curry	Final Disposition:
--	--------------------

**FULL-TIME FACULY OVERLOAD ASSIGNMENTS
SPRING 2025**

INSTRUCTOR	CRN	COURSE	COURSE NAME	FTE
Diaz, Cynthia	Assigned	COUN	COUNSELING UTC Counseling	.015
Youngblood, Brian	40358	ENGR 100	ENGINEERING Introduction to Engineering	.067

PART-TIME FACULTY ASSIGNMENTS - CREDIT
SPRING 2025

INSTRUCTOR	CRN	COURSE	COURSE NAME	FTE
		LAW ENFORCEMENT		
Culver, David	42315	LE 322	Basic Law Enforcement Academy	.044
Dickel, Jason	42315	LE 322	Basic Law Enforcement Academy	.033
Dillard, Bryan	42315	LE 322	Basic Law Enforcement Academy	.033
Esparza, Ruben	42315	LE 322	Basic Law Enforcement Academy	.033
Garrett, William	42315	LE 322	Basic Law Enforcement Academy	.066
George, Kenneth	42315	LE 322	Basic Law Enforcement Academy	.099
Huddle, Kevin	42315	LE 322	Basic Law Enforcement Academy	.033
Lopez, Joe	42315	LE 322	Basic Law Enforcement Academy	.068
Neumann, Timothy	42315	LE 322	Basic Law Enforcement Academy	.174
Magana, George	42315	LE 322	Basic Law Enforcement Academy	.134
McDonald, Jeffrey	42315	LE 322	Basic Law Enforcement Academy	.033
Sorenson, Gregory	42315	LE 322	Basic Law Enforcement Academy	.033
Valle, Jesus	42315	LE 322	Basic Law Enforcement Academy	.099
Vasquez, Frank	42315	LE 322	Basic Law Enforcement Academy	.033

**FULL-TIME FACULTY ASSIGNMENTS - CREDIT
SUMMER 2025**

INSTRUCTOR	CRN	COURSE	COURSE NAME	FTE
		COUNSELING		
Easton, Sarah	Assigned	COUN	LAP Counseling	.125
		MATH		
Chung, Eui	10847	MATH 141	Precalculus	.444
		SOCIOLOGY		
Restrepo, Alberto	10860	SOC 120	Race and Ethnic Groups	.212
		WORK EXPERIENCE EDUCATION		
Manalo, Lauro	10849	WEE	Work Experience Education	.056
Navarrette, Ricardo	10833	WEE	Work Experience Education	.032
Navarrette, Ricardo	10863	WEE	Work Experience Education	.032

**PART-TIME FACULTY ASSIGNMENTS - CREDIT
SUMMER 2025**

INSTRUCTOR	CRN	COURSE	COURSE NAME	FTE
		ANTHROPOLOGY		
Coates, Jenise	10870	ANTH 101	Intro to Biological Anthropology	.001
Coates, Jenise	10871	ANTH 110	Biological Anthropology Lab	.007
		ART		
Thayer, Jill	10865	ART 10865	Art Appreciation	.212
		ASTRONOMY		
Tavakkoly, Aundrea	10844	ASTR 100	Elementary Astronomy	.212
		COUNSLEING		
Machado, Michelle	Assigned	COUN	UTC Counseling – Other Duties	.001
Machado, Michelle	Assigned	COUN	UTC Counseling	.005
		EARLY CHILDHOOD STUDIES		
Caddell, Alice	10850	ECS 100	Child Growth and Development	.212
Shaw, Michael	10104	ECS 100	Child Growth and Development	.212
		ENGLISH		
Meza, Ryan	10677	ENGL C1000	Academic Reading and Writing	.306
		ETHNIC STUDIES		
Espinoza-Kulick, Mario Alberto	10573	ES 121	African American History	.211
		HISTORY		
Moon, Danelle	10269	HIST 120	Chicano History	.211
		LAW ENFORCEMENT		
Burns, Jeremy	10157	LE 426	Patrol Rifle Course	.015
Dillard, Bryan	10157	LE 426	Patrol Rifle Course	.029
Delgado, Matthew	10157	LE 426	Patrol Rifle Course	.061
Gotschall, Christopher	10157	LE 426	Patrol Rifle Course	.032
Valadez, David	10157	LE 426	Patrol Rifle Course	.061
		LIBRARY		
Headtke, Denise	Assigned	Library	Librarian - SM	.048
Hopper, Michelle	Assigned	Library	Librarian - SM	.039
		WORK EXPERIENCE EDUCATION		
Carson, Marcus	10853	WEE	Work Experience Education	.048
Carson, Marcus	10854	WEE	Work Experience Education	.008
Carson, Marcus	10855	WEE	Work Experience Education	.008
George, Kayla	10831	WEE	Work Experience Education	.016
George, Kayla	10832	WEE	Work Experience Education	.008
Gloekner, Robin	10856	WEE	Work Experience Education	.016
Segura, Monique	10794	WEE	Work Experience Education	.064
Segura, Monique	10796	WEE	Work Experience Education	.064

**PART-TIME FACULTY ASSIGNMENTS - NONCREDIT
SUMMER 2025**

INSTRUCTOR	CRN	COURSE	COURSE NAME	FTE
		ENGLISH LANGUAGE DEVELOPMENT NONCREDIT		
Aguila, Raul	10305	ELDN 7420	Newcomer	0.162
Meza, Ryan	10315	ELDN 7440	High Beginning	0.162
		TRUCK DRIVING PROGRAM		
Salazar, Abel	10340	TRCK 7801	Yard Skills	0.027
Salazar, Abel	10347	TRCK 7802	Public Road Truck Driving	0.034

**FACULTY ASSIGNMENTS
FULL-TIME AND PART-TIME FACULTY – STIPENDS**

INSTRUCTOR District Funded	ASSIGNMENT	DOLLAR AMOUNT
Abeson, Scott	To provide not-for-credit training via contract education, law enforcement probation (4/28/25 - 5/1/25).	\$568.72
Allebe, Adrienne	Common course numbering MOU, compensation to convert ART 103 to ARTH C1100 - Survey of Art from Prehistory to the Medieval Era (3/11/25 - 3/12/25).	\$400.00
Arrowsmith, Anna	Attended the 30-hour distance education training. Per PFA agreement, part-time faculty who attend the training will receive \$60 hourly rate (3/31/25 - 5/30/25).	\$1,800.00
Arrowsmith, Anna	Instructor purchased food and supplies for noncredit HOEC 7036 course (3/6/25).	\$50.00
Arvizu-Rodriguez, Maria	Spring 2025 student services council co-chair, daily prorated amount of \$565.68 for four days, article 16.7.1.b (1/21/25 - 5/21/25).	\$2,262.72
Auten, Diane	Academic year 2024-2025 program review: yearly planning update/core topic: enrollment trends and efficiency (1/21/25 - 5/16/25).	\$500.00
Becerra-Valencia, Lynn	Large class stipend, summer 2025, ES/HIST 120 (CRN 10495, 10496) had 94 students enrolled at census. Per faculty agreement 14.6.2 (6/9/25 - 7/17/25).	\$2,550.00
Bianchi, Catherine	To provide not-for-credit training via contract education: Riverside Sheriff (6/10/25 - 6/13/25).	\$1,183.68
Bierly, Gary	Large class stipend, summer 2025, HIST/HUM 101 (CRN 10031, 10036) had 62 students enrolled at census. Per faculty agreement 14.6.2 (6/9/25 - 7/17/25).	\$1,800.00
Bierly, Gary	Large class stipend, summer 2025, HIST/HUM 102 (CRN 10032, 10055) had 58 students enrolled at census. Per faculty agreement 14.6.2 (6/9/25 - 7/17/25).	\$1,800.00
Bierly, Gary	Large class stipend, summer 2025, HIST/HUM 105 (CRN 10082, 10084) had 55 students enrolled at census. Per faculty agreement 14.6.2 (6/9/25 - 7/17/25).	\$1,800.00
Brackett, Ashley	Stipend of \$500.00 for academic year 2024-2025 university transfer center counseling program review: split with Maria Arvizu-Rodriguez (1/22/25 - 5/22/25).	\$250.00
Britten, Benjamin	Academic year 2024-2025 general counseling program review: split with Carissa Perales (1/21/25 - 5/16/25).	\$250.00

**FACULTY ASSIGNMENTS
FULL-TIME AND PART-TIME FACULTY – STIPENDS**

INSTRUCTOR	ASSIGNMENT	DOLLAR AMOUNT
Brunet, Melanie	To provide asynchronous tutoring for the writing center paper submission program (5/2/25 - 5/4/25).	\$150.00
Camarena, Juan	To provide not-for-credit training via contract education: Riverside Sheriff (6/18/25).	\$696.08
Camarena, Juan	To provide not-for-credit training via contract education: Riverside Sheriff (6/11/25).	\$696.08
Cazares, Rocio	To provide not-for-credit training via contract education: Riverside Sheriff (6/19/25).	\$597.12
Cazares, Rocio	To provide not-for-credit training via contract education: Riverside Sheriff (6/13/25).	\$597.12
Clayton, Michelle	30-hour distance education training per PFA faculty will receive \$60 hourly rate (3/31/25 - 5/11/25).	\$1,800.00
Comstock, Marie	Common course numbering MOU, compensation to convert ECON 121 to ECON C2002 - Principles of Macroeconomics (2/24/25 - 3/31/25).	\$200.00
Diaz, Rodolfo	Assisting and instructing students with the DMV exam prep and Class A driving exam (6/13/25 - 6/16/25).	\$652.86
Dickel, Jason	To provide not-for-credit training via contract education: Riverside Sheriff (6/18/25 - 6/20/25).	\$1,212.00
Domingues, Guinevere	30-hour distance education training per PFA faculty will receive \$60 hourly rate (3/31/25 - 5/11/25).	\$1,800.00
Esparza, Ruben	To provide not-for-credit training via contract education: Riverside Sheriff (6/19/25).	\$568.72
Felix, Christopher	30-hour distance education training per PFA faculty will receive \$60 hourly rate (3/31/25 - 5/11/25).	\$1,800.00
Ford, Katherine	To provide asynchronous tutoring for the writing center paper submission program (5/3/25 - 5/17/25).	\$244.95
Garcia, Jesus	To provide not-for-credit training via contract education: Riverside Sheriff (6/19/25).	\$568.72
Garrett, William	To provide not-for-credit training via contract education: Riverside Sheriff (6/17/25 - 6/20/25).	\$1,844.16

**FACULTY ASSIGNMENTS
FULL-TIME AND PART-TIME FACULTY – STIPENDS**

INSTRUCTOR	ASSIGNMENT	DOLLAR AMOUNT
George, Kayla	Stipend for academic year 2024-2025 recreation management program review: yearly planning update/core topic: enrollment trends and efficiency - split with Eliseo Munoz and Charles Provencio (1/22/25 - 5/22/25).	\$125.00
George, Kenneth	To provide not-for-credit training via contract education: Riverside Sheriff (6/17/25).	\$636.72
George, Kenneth	To provide not-for-credit training via contract education: Riverside Sheriff (6/10/25).	\$636.72
Greene, Jeffrey	To provide not-for-credit training via contract education: Riverside Sheriff (6/19/25).	\$568.72
Greene, Jeffrey	To provide not-for-credit training via contract education: Riverside Sheriff (6/13/25).	\$568.72
Halderman, Anthony	To provide asynchronous tutoring for the writing center paper submission program (5/11/25).	\$84.59
Hall, Roger	Large class stipend, summer 2025. HIST 107, CRN 10033, had 55 students enrolled at census. Per faculty agreement 14.6.2 (6/9/25 - 7/17/25).	\$1,800.00
Henderson, Bruce	To provide asynchronous tutoring for the writing center paper submission program (5/9/25 - 5/16/25).	\$85.04
Hernandez, Armando	Instructor provided assistance for the truck driving program's orientation (5/1/25).	\$72.54
Huddle, Kevin	To provide not-for-credit training via contract education: Riverside Sheriff (6/18/25).	\$696.08
Huddle, Kevin	To provide not-for-credit training via contract education: Riverside Sheriff (6/11/25 - 6/12/25).	\$1,392.16
King, Suzanne	Shopping and coordinate during instructors' absence (5/29/25 - 7/31/25).	\$2,990.72
Koch, Alfredo	Monitoring activities in the vineyard related to outside vendors, doing work, and being available to assist in the winery for activities requiring more than one person (7/1/25 - 7/31/25).	\$2,611.20
Koch, Alfredo	Monitoring activities in the vineyard related to outside vendors, doing work, and being available to assist in the winery for activities requiring more than one person (6/2/25 - 6/27/25).	\$2,611.20
Kopecky, Susannah	To provide asynchronous tutoring for writing center paper submission program (5/19/25).	\$30.00

**FACULTY ASSIGNMENTS
FULL-TIME AND PART-TIME FACULTY – STIPENDS**

INSTRUCTOR	ASSIGNMENT	DOLLAR AMOUNT
Lopez, Joe	To provide not-for-credit training via contract education: Riverside Sheriff (6/16/25 - 6/18/25).	\$2,440.32
Lopez, Joe	To provide not-for-credit training via contract education: Riverside Sheriff (6/9/25 - 6/12/25).	\$3,253.76
Lowery, Herod	Assisting and instructing students with the DMV exam prep and Class A driving exam (6/3/25 - 6/9/25).	\$834.21
Lowery, Herod	Assisting and instructing students with the DMV exam prep and class A driving exam (6/2/25).	\$217.62
Lowery, Herod	Assisting and instructing students with the DMV exam prep and class A driving exam (5/30/25).	\$398.97
Lowery, Herod	Assisting and instructing students with the DMV exam prep and class A driving exam (5/29/25).	\$199.49
Lowery, Herod	Assisting and instructing students with the DMV exam prep and class A driving exam (5/28/25).	\$199.49
Lowery, Herod	Assisting and instructing students with the DMV exam prep and class A driving exam (5/27/25).	\$217.62
Lowery, Herod	Assisting and instructing students with the DMV exam prep and class A driving exam (5/23/25).	\$362.70
Lowery, Herod	Assisting and instructing students with the DMV exam prep and Class A driving exam (4/28/25).	\$389.90
Lowery, Herod	Assisting and instructing students with the DMV exam prep and Class A driving exam (3/20/25).	\$253.89
Lowery, Herod	Assisting and instructing students with the DMV exam prep and Class A driving exam (2/28/25).	\$145.08
Lowery, Herod	Assisting and instructing students with the DMV exam prep and Class A driving exam (2/17/25).	\$226.69
Lowery, Herod	Assisting and instructing students with the DMV exam prep and Class A driving exam (2/7/25).	\$408.04
Madrigal, Hector	To provide not-for-credit training via contract education: Riverside Sheriff (6/17/25 - 6/18/25).	\$1,336.80
Magana, Jorge	Non-instructional, summer 2025 coordination duties for perishable skills program not-for-credit courses, coordinate training dates with agency training managers and schedule training courses (8/1/25 - 12/11/25).	\$12,125.70

**FACULTY ASSIGNMENTS
FULL-TIME AND PART-TIME FACULTY – STIPENDS**

INSTRUCTOR	ASSIGNMENT	DOLLAR AMOUNT
Magana, Jorge	Non-instructional, summer 2025 coordination duties for perishable skills program not-for-credit courses, coordinate training dates with agency training managers and schedule training courses (6/9/25 - 7/31/25).	\$2,425.14
Magana, Jorge	To provide not-for-credit training via contract education: Riverside Sheriff (6/9/25 - 6/13/25).	\$2,959.20
Martinez, Alison	Non-instructional, summer 2025 LE 321/322 coordination duties for the law enforcement academy program (7/7/25 - 12/3/25).	\$14,283.36
Martinez, Alison	Non-instructional, summer 2025 LE 321/322 coordination duties for the law enforcement academy program (6/12/25 - 7/9/25).	\$3,139.20
Martinez, Merari	Assisting and instructing students with DMV exam prep and class A driving exam (5/27/25).	\$199.49
Martinez, Merari	Assisting and instructing students with DMV exam prep and class A driving exam (5/21/25).	\$181.35
Martinez, Merari	Assisting and instructing students with DMV exam prep and class A driving exam (5/16/25).	\$380.84
Martinez, Merari	Assisting and instructing students with the DMV exam prep and Class A driving exam (4/25/25).	\$326.43
McDonald, Jeffrey	To provide not-for-credit training via contract education: Riverside Sheriff (6/10/25).	\$507.76
Meza, Ryan	Screening and escorting time at Lompoc prison education department (1/21/25 - 5/21/25).	\$666.54
Millan, Jose	Planned, coordinated, and facilitated group counseling sessions for the men's support group (1/21/25 - 5/8/25).	\$1,380.00
Miller, Andre	To provide not-for-credit training via contract education: Riverside Sheriff (6/20/25).	\$507.76
Mills, Daniel	Assisting and instructing students with DMV exam prep and class A driving exam (5/12/25).	\$326.43
Morales, Mayra	Coordinate pathways that lead to ECSN certificate completion and/or non-credit to credit transition (1/21/25 - 5/14/25).	\$4,500.00
Munoz, Eliseo	Per program review MOU: enrollment trends and efficiency for the 2025-26 academic year, split with Charles Provencio and Kayla George (1/22/25 - 5/22/25).	\$125.00

**FACULTY ASSIGNMENTS
FULL-TIME AND PART-TIME FACULTY – STIPENDS**

INSTRUCTOR	ASSIGNMENT	DOLLAR AMOUNT
Murray, Thomas	Assisting and instructing students with DMV exam prep and class A driving exam (5/19/25).	\$181.35
Neumann, Timothy	To provide not-for-credit training via contract education: Riverside Sheriff (6/16/25 - 6/20/25).	\$3,314.40
Neumann, Timothy	To provide not-for-credit training via contract education: Riverside Sheriff (6/11/25 - 6/13/25).	\$2,651.52
Nishimori, Melinda	Program review year 2024-2025: yearly planning update/core topic: academic services and support. Stipend split with George Phelan (1/21/25 - 5/16/25).	\$250.00
Perales, Carissa	Program review year 2024-2025: general counseling, split between Benjamin Britten and Carissa Perales (1/21/25 - 5/31/25).	\$250.00
Peters, Dawn	30-hour distance education training per PFA faculty will receive \$60 hourly rate (3/31/25 - 5/11/25).	\$1,800.00
Phelan, George	Academic year 2024-2025 program review yearly planning update/core topic: academic services and support, split with Melinda Nishimori (1/21/25 - 5/16/25).	\$250.00
Provencio, Charles	Per program review MOU: enrollment trends and efficiency for the 2025-26 academic year, split with Eliseo Munoz and Kayla George (1/22/25 - 5/22/25).	\$250.00
Rivera, Lisa	To provide not-for-credit training via contract education, law enforcement probation (5/20/25 - 5/22/25).	\$1,652.06
Romo, Alina	Academic year 2024-2025 for program review core topic: curriculum and teaching design (1/21/25 - 5/16/25).	\$500.00
Rucker, Justin	Academic year 2024-2025 for CNET program review: yearly planning update/core topic: education and industry partners (5/20/25 - 5/30/25).	\$500.00
Sherrod, Jerry	Screening and escorting time at Lompoc prison education department (6/6/25 - 7/31/25).	\$466.55
Sherrod, Jerry	Screening and escorting time at Lompoc prison education department for (1/21/25 - 5/24/25).	\$964.56
Shields, Nathan	Screening and escorting time at Lompoc prison education department (1/21/25 - 5/21/25).	\$716.94
Sorenson, Gregory	To provide not-for-credit training via contract education: Riverside Sheriff (6/17/25).	\$568.72

**FACULTY ASSIGNMENTS
FULL-TIME AND PART-TIME FACULTY – STIPENDS**

INSTRUCTOR	ASSIGNMENT	DOLLAR AMOUNT
Stokes, Brian	Large class stipend, summer 2025, ANTH 101 (CRN 10028) had 55 students enrolled at census. Per faculty agreement 14.6.2 (6/9/25 - 7/17/25).	\$1,800.00
Stokes, Brian	Large class stipend, summer 2025, ANTH 102 (CRN 10029) had 60 students enrolled at census. Per faculty agreement 14.6.2 (6/9/25 - 7/17/25).	\$1,800.00
Tobias, Gabriel	To provide not-for-credit training via contract education, law enforcement probation (5/20/25 - 5/22/25).	\$1,528.43
Valle, Jesus	To provide not-for-credit training via contract education: Riverside Sheriff (6/10/25).	\$2,274.88
Valle, Jesus	To provide not-for-credit training via contract education: CAL OES (5/13/25 - 5/15/25).	\$1,137.44
Valle, Jesus	To provide not-for-credit training via contract education (4/25/25).	\$568.72
Vasquez, Frank	To provide not-for-credit training via contract education: Riverside Sheriff (6/20/25).	\$662.88

Grant Funded

Aguila, Raul	Professional development for ELDN (5/16/25).	\$82.32
Aguilera, Virginia	Professional development for ELDN (5/16/25).	\$94.08
Aleman, Florentino	Professional development for ELDN (5/16/25).	\$89.02
Aleman, Florentino	Assessments for the ELDV and ECSN courses (3/3/25 - 3/24/25).	\$445.10
Ambriz Delgado, Alberto	Professional development for ELDN (5/16/25).	\$80.82
Bergstrom Smith, Joan	Professional development for ELDN (5/16/25).	\$95.88
Caddell, Alice	Research apprenticeships relating to ECS, coordinate apprenticeship opportunities, recruit students into the program and grant reporting (5/13/25 - 6/30/25).	\$3,200.40
Cardona, Fabiola	Professional development for ELDN (5/16/25).	\$77.42
Carson, Marc	Industry coach to connect classrooms to careers by preparing and supporting CNC bootcamp activities (5/1/25 - 6/30/25).	\$1,318.50
Colvin, Samuel	Professional development for ELDN (5/16/25).	\$84.12
Cox, Matthew	Professional development for ELDN (5/16/25).	\$82.32
Dominguez, Aurea	Professional development for ELDN (5/16/25).	\$94.08

**FACULTY ASSIGNMENTS
FULL-TIME AND PART-TIME FACULTY – STIPENDS**

INSTRUCTOR	ASSIGNMENT	DOLLAR AMOUNT
Drake, William	Completed course curriculum review for truck driving program (5/11/25 - 5/27/25).	\$226.69
Eachus, Christopher	To serve as the facilitator of the online skills lab for Math 141, 181, and 182, summer and fall 2025 (6/16/25 - 12/5/25).	\$4,500.00
Faries, Martin	Professional development for ELDN (5/16/25).	\$94.08
Fox, Alicia	PI work on bridges to baccalaureate grant (9/1/24 - 6/30/25)	\$4,906.44
Garcia, Katherine	Professional development for ELDN (5/16/25).	\$98.98
Gottlieb, Sean	PI work on bridges to baccalaureate grant (9/1/24 - 6/30/25)	\$4,183.47
Gottlieb, Sean	Co-facilitator of the online skills lab for CHEM 120, 150, 151, summer and fall 2025 (6/16/25 -12/5/25).	\$1,320.00
Hall, Bailey	Registration rally and additional counseling appointments (5/2/25 - 5/22/25).	\$505.30
Hughes, Michael	Co-facilitator of the online skills lab for CHEM 120, 150, 151, summer and fall 2025 (6/16/25 -12/5/25).	\$3,180.00
Krier, Erin	Oversee the agriculture and plant sciences field operations (6/1/25 - 7/18/25).	\$8,400.00
Legaspi, Jose	Professional development for ELDN (5/16/25).	\$82.32
Morris, Holly	Attended required Prison Rape Elimination Act (PREA) training addressing how to prevent, detect, and respond to sexual abuse (6/17/25).	\$137.16
Muscio, Michael	Professional development for ELDN (5/16/25).	\$82.32
Nunez, Christina	Preparation, implementation and follow up on the fall 2025 professional development session offered to CCAP English teachers focusing on common course numbering for ENGL C1000 and ENGL C1001 (5/1/25 - 5/22/25).	\$720.00
Olmeda, Sharaya	Embedded librarian services for ENGL 101, Kacie Wills (4/1/25 - 5/31/25).	\$900.00
Olmeda, Sharaya	Embedded librarian services for ENGL 101/112, Chellis Ying Hood (4/1/25 - 5/31/25).	\$900.00
Perales, Carissa	Guided pathways lead, program maps, website, outreach, planning and training retention specialist (6/2/25 - 7/25/25).	\$720.00
Ramos-Martinez, Hector	Coordinate and prepare a machining and manufacturing bootcamp (5/1/25 - 6/30/25)	\$9,000.00

**FACULTY ASSIGNMENTS
FULL-TIME AND PART-TIME FACULTY – STIPENDS**

INSTRUCTOR	ASSIGNMENT	DOLLAR AMOUNT
Raybould-Rodgers, Julia	Preparation, implementation and follow up on the fall 2025 professional development session offered to CCAP English teachers focusing on common course numbering for ENGL C1000 and ENGL C1001 (5/1/25 - 5/22/25).	\$720.00
Rucker, Justin	2025 MATE ROV World Championships student advisor (6/17/25 - 6/21/25).	\$1,800.00
Ruiz, Melissa	Professional development for ELDN (5/16/25).	\$84.12
Sanchez, Heladia	Professional development for ELDN (5/16/25).	\$77.42
Sanchez, Veronica	Evaluate 2026 LVN and RN applications for prerequisites, general education, and other related requirements (6/1/25 - 7/31/25).	\$3,600.00
Santiago, Oyuki	Professional development for ELDN (5/16/25).	\$80.82
Schug, Greg	2025 MATE ROV World Championships student advisor (6/17/25 - 6/21/25).	\$1,569.60
Tirona, Virginia	Represented the district through attendance at the chancellor's office ZTC conference (5/9/25).	\$292.63
Trimbath, Patrick	Common course numbering MOU, compensation to convert ART 104 to ARTH C1200 - Survey of Art from Renaissance to Contemporary (3/11/25 - 3/12/25).	\$400.00
Walters, Jan	Professional development for ELDN (5/16/25).	\$95.88

To: Board of Trustees	Date:
From: Superintendent/President	July 15, 2025
Subject: Approval of Equivalency Certification for Faculty	Item Number: 8.E.
Institutional Goal: Accreditation Standard III	Enclosures: Page 1 of 5

BACKGROUND

In accordance with California Code of Regulations Title 5, Division 6, Chapter 4, Subchapter 4, Article 2, Section 53410, and Allan Hancock College's board policy 7211, those who have equivalent qualifications to the state minimum qualifications as established by the Board of Governors can teach classes within their designated discipline areas.

Attached are the equivalency certifications for faculty members who have been authorized to teach credit or noncredit classes, as needed, at Allan Hancock College based on equivalency criteria specified in board policy 7211 and as restricted by the equivalency certification document.

Regular Equivalency Certification

<u>Name</u>	<u>Discipline</u>
Collette, Christel	Home Economics (noncredit)
Miller, Edward	Vocational Community Ed (Commercial Truck Driving)

FISCAL IMPACT

None

RECOMMENDATION

Staff recommends the board of trustees approve the attached equivalency certifications for the faculty members who have been authorized to teach, as needed, based on equivalency criteria specified in board policy 7211 and as restricted by the equivalency certification document.

Administrator Initiating Item: Robert Curry	Final Disposition:
--	--------------------

**Equivalency Certification for Noncredit
Home Economics**

Name: Collette Christel Department: Community Education
Semester/Year: Fall 2025 Discipline/Area: HOEC

Criteria for Equivalency: The applicant named above meets the criteria for equivalency. This has been verified by review of the applicant's official college transcripts and other materials. (Attach documents used to verify candidate's qualifications.)

Minimum Qualifications:

Bachelor's degree in home economics, life management, family and consumer studies, dietetics, food management interior design, or clothing and textiles; or an associated degree in any of those subjects and four years of professional experience related to the subject of the course taught.

Criteria for Equivalency:

- A bachelor's degree in any discipline and 24 semester credit units in the designated major field related to the subject of the course taught.
- An associate degree in any discipline and four years of professional experience related to the subject of the course taught.
- Recognized accomplishments which demonstrate eminence of expertise and skills in the field of study clearly beyond those that are normal and evidence of attaining course work or experience equal to the general education requirements as outlined in Title 5 section 55063.
- Licensure or certification to teach in a discipline where the licensure or certification requires specified hours of formal instruction.
- Six years continuous related experience and evidence of attaining course work or experience equal to the general education requirements as outlined in Title 5 section 55063.

Rationale: Explain how the applicant's qualifications meet the selected guideline. Qualifications must be verified with appropriate documentation.

The candidate is being recommended for equivalency certification to teach in the discipline of Home Economics based on six years of continuous, directly related professional experience in the field, which aligns with the minimum qualifications for equivalency as outlined by the California Community Colleges Chancellor's Office.

Verification of employment has been provided and confirms that the candidate has consistently worked in a professional capacity within areas directly related to Home Economics. This experience has equipped the candidate with the applied knowledge and practical expertise necessary to teach subject matter within the discipline effectively.

While the candidate may not possess the traditional academic degree in Home Economics, the depth and continuity of professional experience demonstrate competency and content mastery equivalent to the degree requirement.

Therefore, based on documented experience and employment verification, the candidate meets the equivalency standard for teaching in this discipline.

Signature of Candidate <u>Collette Christel</u> <small>Collette Christel (May 28, 2025 15:02 PDT)</small>	Date <u>05/28/2025</u>
--	------------------------

I have reviewed all documentation and recommend approval of regular equivalency certification.			
Signature of Department Chair	Date	<u>[Signature]</u> Signature of Dean	<u>06/03/2025</u> Date
<u>[Signature]</u> Signature of Appropriate Academic Vice President	<u>06/05/2025</u> Date	<u>David DeGroot</u> Signature of Committee Chair Professional Standards Committee	<u>06/05/2025</u> Date

**Equivalency Certification for Noncredit
Short-term Vocational**

Name: Edward Miller Department: Community Education
Semester/Year: Summer 2025 Discipline/Area: Commercial Truck Driving

Criteria for Equivalency: The applicant named above meets the criteria for equivalency. This has been verified by review of the applicant's official college transcripts and other materials. (Attach documents used to verify candidate's qualifications.)

Minimum Qualifications

A bachelor's degree and two years of occupational experience related to the subject of the course taught, or
An associate degree, and six years of occupational experience related to the subject of the course taught, or
Possession of a full-time clear California Designated Subjects Adult Education Teaching Credential authorizing instruction in the subject matter, or
For courses in an occupation for which the district offers or has offered apprenticeship instruction, the minimum qualifications for noncredit apprenticeship instructors in that occupation, as specified in Section 53413.

Criteria for Equivalency

- Licensure or certification in a vocational area where the license or certification requires specified hours of formal instruction and four years of professional experience in the area of specialization in lieu of formal college preparation and evidence of attaining coursework or experience equal to the general education requirements as outlined in Title 5 section 55063.
- Recognized accomplishments which demonstrate expertise and skills in the field of study clearly beyond those that are normal and evidence of attaining coursework or experience equal to the general education requirements as outlined in Title 5 section 55063.

Rationale: Explain how the applicant's qualifications meet the selected guideline. Qualifications must be verified with appropriate documentation.

GE Area A - See Attached
GE Area B - See Attached
GE Area C - See Attached
GE Area D - See Attached
GE Area D1 - See Attached
GE Area D2 - See Attached
GE Area D generic - See Attached

Signature of Candidate Ed Miller Date 06/26/2025
Ed Miller (Jun 26, 2025 15:16 PDT)

I have reviewed all documentation and recommend approval of regular equivalency certification.			
<u>Delicia Navarrette</u> Signature of Department Chair	6/25/25 Date	<u>Alicia Frazier</u> Signature of Dean	06/26/2025 Date
<u>[Signature]</u> Signature of Appropriate Academic Vice President	06/26/2025 Date	<u>David DeGroot</u> Signature of Committee Chair Professional Standards Committee	06/26/2025 Date

Commercial Truck Driver Equivalency Template

Candidate's name: Abel Salazar

Term/Year: Summer 2025

Date of submission: June 25, 2025

GE Area A:

- A certified commercial truck driver must apply the scientific method to interpret service manuals, understand the theory of the systems being diagnosed, develop an initial hypothesis based on customer input, follow testing and diagnostic procedures to isolate and repair system defects and verify the repair resolved the system defect.
- A commercial truck driver must understand principles of fluid dynamics and hydraulics, the composition of friction materials, and automotive electrical systems.
- Applicant also hold a Class A commercial driver's license

GE Area B:

- A commercial truck driver must possess the ability to understand and communicate with diverse customers with diverse needs. Technicians must utilize knowledge of social groups to interact constructively, communicate effectively, and to manage customer and internal relations.
- A self-employed commercial truck driver or business owner must apply microeconomic and macroeconomic concepts to predict and respond to market forces on consumer spending.

GE Area C:

- SPAN/ENGL bilingual: The Commercial Truck Driving candidate is at a functional level of the Spanish language. They have a basic command of the language needed in a limited range of simple, routine, and familiar tasks and situations. For example, they can understand and pass on simple messages, are able to deal with simple, straightforward information, and are able to maintain simple face-to-face conversations, using at least one form of the present, past, and future tenses. At this level the candidate can understand and use up to 1,000 of the most frequently encountered or personally relevant vocabulary items.

GE Area D:

D1:

- A licensed commercial truck driver must effectively translate results of a vehicle diagnosis into written form to either the service advisor or customer in such a way that a layperson can understand the diagnosis and repair of the vehicle (English Composition).

- A licensed commercial truck driver must effectively research repair manuals, databases, and other sources to locate necessary information to understand problems and to propose and perform necessary repairs.

D2:

- A licensed commercial truck driver must demonstrate the ability to decipher information from the customer in either oral or written form regarding their vehicle complaint and use of the information to diagnose the vehicle problem causing the customer's concern and communication of findings either orally or in written form to the service advisor or customer.
- For a licensed commercial truck driver, every aspect of a job revolves around analytic thinking skills. Analytic thinking skills are used to confirm a customer's concern, perform root-cause diagnostic procedures, and verify the repair.
- A licensed commercial truck driver must use mathematical skills to manage and calculate ratios, measurements, comparisons, and specifications related to investigation of problems, development of appropriate repair solutions, and performance of repair. A licensed automotive technician may also apply mathematical skills and reasoning to machine parts and tools, to exacting specifications.

D generic:

- As a licensed commercial truck driver, applicant must effectively translate results of a vehicle diagnosis into written form to either the service advisor or customer in such a way that a layperson can understand the diagnosis and repair of the vehicle (English Composition). Further, as a licensed commercial truck driver, applicant must effectively research repair manuals, databases, and other sources to locate necessary information to understand problems and to propose and perform necessary repairs.
- As a business owner/manager, applicant must also clearly understand all laws and regulations connected to running a business, hiring and recruitment, drug and alcohol testing, employee supervision, and be current in training aspects such as sexual and workplace harassment training, including training related to his employment/business.
- Applicant is also certified via the "Supervisor's Guide to Reasonable Suspicion Management Training."

To: Board of Trustees	Date: July 15, 2025
From: Superintendent/President	
Subject: Second Review of K-12 CCAP Agreements with the School Districts	Item Number: 8.F.
Institutional Goal: Ed Master Plan Goal D. Student Completion	Enclosures: Page 1 of 181

BACKGROUND

This year, Allan Hancock College will enter into new College and Career Access Pathways (CCAP) partnership agreements with each of our K-12 high school partners. These contracts will be in effect for three years and they will replace our existing non-CCAP agreements. We are asking the board of trustees to review the contracts for the following school districts as it will need two readings, followed by approval to implement the contracts in fall 2025.

- Brawley Union School District (out of service area)
- Lompoc Unified School District
- Orcutt Union School District
- Santa Maria Joint Union High School District
- Santa Ynez Valley Union High School District

The agreements were submitted for the board's review on June 10, 2025, and are being presented to the board of trustees for adoption.

FISCAL IMPACT

None

RECOMMENDATION

Staff recommends the board of trustees adopt the K-12 CCAP agreements with the high school districts, as submitted.

Administrator Initiating Item: Robert Curry	Final Disposition:
--	--------------------

**COLLEGE AND CAREER ACCESS PATHWAYS (CCAP)
PARTNERSHIP AGREEMENT
BETWEEN
THE ALLAN HANCOCK JOINT COMMUNITY COLLEGE DISTRICT
AND
BRAWLEY UNION SCHOOL DISTRICT**

This College and Career Access Pathway Partnership Agreement (“CCAP Agreement”) is between the Allan Hancock Joint Community College District (“COLLEGE) and Brawley Union School District (“SCHOOL DISTRICT”). COLLEGE and SCHOOL DISTRICT will collectively be referred to as “PARTIES” or individually as “PARTY”.

RECITALS

WHEREAS, COLLEGE is a community college district whose mission includes providing educational programs and services that are responsive to the needs of the students and communities within the community college services area; and

WHEREAS, SCHOOL DISTRICT is a public school district located within the regional service area of the COLLEGE unless otherwise specified and agreed to as stated in AB 288, Sec. 2, Education Code section 76004, subdivision (e); and

WHEREAS, a high school (“HIGH SCHOOL”) “includes a community school, continuation high school, juvenile court school, or adult education program offering courses for high school diplomas or high school equivalency certificates” as stated in Education Code section 76004, subdivision (a)(2); and

WHEREAS, the PARTIES desire to enter into this CCAP Agreement for the purpose of offering or expanding dual enrollment opportunities, consistent with the provisions of the Education Code, for high school students “who may not already be college bound or who are underrepresented in higher education with the goal of developing seamless pathways from high school to community college for career technical education or preparation for transfer, improving high school graduation rates, and helping high school pupils achieve college and career readiness,” (Ed. Code, § 76004, subdivision (a)); and

WHEREAS, instruction will comply with the student selection standards, curriculum guidelines, recommendations and procedures promulgated by applicable law, the California Community College Chancellor’s Office and the COLLEGE; and

WHEREAS, the PARTIES desire to enter this CCAP, which sets forth their mutual rights and responsibilities and governs their relationship; and

WHEREAS, the PARTIES intend for COLLEGE to report full-time equivalent students (“FTES”) and obtain state apportionment for the subject courses given through this CCAP Agreement in

accordance with California Education Code, section 76004 and the appropriate portions of Title 5 of the California Code of Regulations; and

WHEREAS, participation in the CCAP Agreement is consistent with the core mission of California Community Colleges pursuant to Education Code section 66010.4, and that pupils participating in a CCAP partnership will not lead to enrollment displacement of otherwise eligible adults in the community college (Ed. Code, § 76004, subdivision (k)(2));

NOW, THEREFORE, PARTIES mutually agree as follows:

1. TERM OF AGREEMENT

1.1. **Effective Date and Duration.** The term of this CCAP Agreement shall be effective on **July 1, 2025**, and continue in effect until **June 30, 2026**, or until duly modified or terminated by the PARTIES in accordance with Section 1.2 of this CCAP Agreement.

1.2. Early Termination.

- a. This agreement may be terminated by either PARTY without cause or for any reason upon giving at least sixty (60) days prior written notice to the other PARTY. Any students currently enrolled in COLLEGE courses under this CCAP Agreement shall be allowed to complete those courses prior to the termination of this CCAP Agreement.
- b. This CCAP Agreement may be terminated by either PARTY with cause if another PARTY fails to comply with the insurance or indemnification requirements or otherwise commits a material breach. Termination will be effective no sooner than 15 calendar days after a written demand to cure is provided and the PARTY fails to cure. This remedy is in addition to any other remedy which may be provided for by law.

1.3. **The CCAP Agreement Appendix.** This CCAP Agreement outlines the terms of the Agreement.

- a. The CCAP Agreement Appendix shall specify CCAP Agreement Courses as well as additional details regarding, but not be limited to, the total number of high school students to be served and the total number of full-time equivalent students (“FTES”) projected to be claimed by the community college district for those students; the scope, nature, time, location, and listing of community college courses to be offered; and criteria to assess the ability of pupils to benefit from those courses:

Appendix A: Agreement with Instructor.

Appendix B: Identification of CCAP Pathways for Course-Specific College and Career Pathway Opportunities.

Appendix C: CCAP Agreement Courses Approved for 2025-2026.

Appendix D: Registration Timeline

- b. The CCAP Agreement Appendix C shall be reviewed and approved annually by both PARTIES by a duly adopted written amendment to this Agreement.

1.4. **Points of contact and Educational Administrators** are as follows:

COLLEGE: Thomas Lamica, dean, academic affairs
 SCHOOL DISTRICT: Jonine Trevino, director of special projects
 HIGH SCHOOL SITE: Jesse Sanchez, principal

(Ed. Code, § 76004, subdivision (c)(2))

- 1.5. A copy of the COLLEGE and SCHOOL DISTRICT CCAP Agreement shall be filed with the office of the Chancellor of the California Community Colleges and with the California Department of Education before the start of the CCAP partnership. (Ed. Code, § 76004, subdivision (c)(3).)
- 1.6. COLLEGE and SCHOOL DISTRICT shall present this CCAP agreement at an open public meeting of their respective governing boards, allowing for public comments prior to consideration for approval or disapproval of this CCAP agreement. (Ed. Code, § 76004, subdivision (b)(2).)

2. DEFINITIONS

- 2.1. **CCAP Agreement Courses.** CCAP Agreement Courses offered as part of this CCAP Agreement shall be community college courses acceptable towards a career technical education credential or certificate, preparation for transfer, or appropriate to improve high school graduation rates or help high school pupils achieve college and career readiness. (Ed. Code § 76004, subdivision (a).) All community college courses offered at the SCHOOL DISTRICT have been approved in accordance with the policies and guidelines of COLLEGE and applicable law. Courses offered at the COLLEGE that are open to the public for enrollment fall outside of this CCAP agreement and are subject to all conditions and rules of the COLLEGE.
- 2.2. **Pupil or Student Fees.** Pupil or Student is defined as a resident or nonresident student attending HIGH SCHOOL in California. SCHOOL DISTRICT pupils enrolled in a course offered through this CCAP Agreement shall not be assessed any fee that is prohibited by Education Code section 49011 (Ed. Code § 76004, subdivision (f)), including a fee charged to a student or a student's parent or guardian as a condition for course registration or for textbooks, supplies, materials and equipment needed to participate in the course. Students who are enrolled in a combination of CCAP and regular credit college courses will be subject to all fees assessed for the regular credit college enrollment for the regular credit college courses.

3. STUDENT ELIGIBILITY, SELECTION AND ENROLLMENT, ADMISSION, REGISTRATION, MINIMUM SCHOOL DAY

- 3.1. **Student Eligibility.** Students who "may not already be college bound or who are underrepresented in higher education, with the goal of developing seamless pathways from

high school to community college for career technical education or preparation for transfer, improving high school graduation rates, or helping high school pupils to achieve college and career readiness" and "underachieving students, those from groups underrepresented in postsecondary education, those who are seeking advanced studies while in high school, and those seeking a career technical education credential or certificate" are eligible to participate in CCAP courses hosted at a SCHOOL DISTRICT site. (Education Code § 76004, subdivision (a); Assembly Bill 288 (2015) Section I, subdivision (d))

- 3.2. **Student Selection and Enrollment.** Enrollment shall be open to all eligible students as part of the CCAP Agreement who have been admitted to the COLLEGE and who meet all applicable prerequisites. Student selection criteria will be further specified in the CCAP Agreement Appendix C. Applicable prerequisite courses, training, or experience and standards required as preparation for courses offered through the CCAP Agreement will be determined by COLLEGE and shall be in compliance with applicable law and COLLEGE standards and policies.
- 3.3. **College Admission and Registration.** Procedures for students participating in the CCAP Agreement shall be governed by the COLLEGE and shall be in compliance with the admissions and registration guidelines outlined in applicable law and COLLEGE policy.
- 3.4. **Records of Student Attendance.** All records of student attendance and achievement shall be submitted to COLLEGE periodically using the COLLEGE student information system or upon demand and shall be maintained by COLLEGE.
- 3.5. **Priority Enrollment.** Students enrolling in a CCAP course will have priority enrollment by virtue of their status. High school students enrolling in non-CCAP college courses will not be eligible for priority registration.
- 3.6. **Physical Education Courses.** As part of a CCAP Agreement, a participating community college district shall not provide physical education course opportunities to high school students or any other course opportunities that do not assist in the attainment of the goals associated with career technical education or preparation for transfer, improving high school graduation rates, or helping high school students achieve career and college readiness. (Ed. Code § 76004, subdivision (d)).
- 3.7. **Maximum Units.** Students participating under a CCAP Agreement may enroll in up to a maximum of 15 units per term, without exception, if all the following conditions specified in Assembly Bill 288, Sec. 2 (p)(1)(2)(3) are satisfied:
 - a. The units constitute no more than four community college courses per term.
 - b. The units are part of an academic program that is part of a CCAP partnership agreement established pursuant to this article.
 - c. The units are part of an academic program that is designed to award students both a high school diploma and an associate degree or a certificate or credential.
- 3.8. **Minimum School Day.** The SCHOOL DISTRICT shall certify that it shall teach SCHOOL DISTRICT students participating as part of a CCAP Agreement no less than the number of instructional minutes required to complete a minimum school day pursuant to Education Code sections 46141 and 46142.
- 3.9. **Enrollment Restriction.** COLLEGE reserves the right to block students from enrolling in any courses for students who incur an unpaid debt for a non-CCAP class at the college. COLLEGE agrees to remove the enrollment block when debt is paid in full.

4. COLLEGE APPLICATION PROCEDURE

- 4.1. The COLLEGE will be responsible for processing student applications.
- 4.2. The COLLEGE will provide the necessary admission and registration forms and procedures, and both COLLEGE and SCHOOL DISTRICT will jointly ensure that each applicant accepted has met all the enrollment requirements.
- 4.3. The SCHOOL DISTRICT agrees to assist COLLEGE in the admission and registration of SCHOOL DISTRICT students as may be necessary and requested by COLLEGE.

5. PARTICIPATING STUDENTS

- 5.1. The total cost of books and instructional materials for SCHOOL DISTRICT students who enroll in a COLLEGE course offered as part of this CCAP Agreement will be borne by SCHOOL DISTRICT.
- 5.2. The SCHOOL DISTRICT will ensure that ancillary and support services are accessible to students (e.g., Tutoring.). Student support services will not be provided by the COLLEGE.
- 5.3. A student taking courses under this CCAP Agreement with an Individual Education Plan or 504 Plan with the SCHOOL DISTRICT may request accommodation for his or her disability to participate in the educational programs and activities required by the COURSE and COLLEGE. Accommodation required by state law or SCHOOL DISTRICT policy will be provided through SCHOOL DISTRICT in consultation with the COLLEGE Learning Assistance Program (LAP) Office. Students requesting services by the LAP office will need to follow the standard process for requesting accommodations.

6. CCAP AGREEMENT COURSES

- 6.1. The COLLEGE may limit enrollment in a community college course solely to eligible high school students if the course is offered at a high school campus during the regular school day and the community college course is offered pursuant to this CCAP Agreement.
- 6.2. The COLLEGE is responsible for all courses and educational programs offered as part of CCAP Agreement .
- 6.3. The scope, nature, time, location, and listing of courses offered by a COLLEGE shall be determined by COLLEGE in consultation with the SCHOOL DISTRICT and with the approval of the COLLEGE and will be recorded in the Appendix C to this CCAP Agreement.
- 6.4. Courses offered as part of a CCAP Agreement shall be jointly selected and approved by COLLEGE and SCHOOL DISTRICT.
- 6.5. Courses offered as part of this CCAP Agreement shall have a minimum enrollment of fifteen (15) students.
- 6.6. The SCHOOL DISTRICT confirms that each approved CCAP course is held for no less than 50 minutes each class day in full compliance with the course outcomes determined by the COLLEGE.
- 6.7. Degree and certificate programs that are included in the CCAP agreement must have been approved by the California Community College Chancellor's Office and courses offered at the SCHOOL DISTRICT shall adhere to the official course outline of record and the student

- learning outcomes established by the associated academic department within the COLLEGE, approved by the COLLEGE Academic Policy & Planning (AP&P) Committee and submitted to the Chancellor's Office. Course outlines will be provided to the SCHOOL DISTRICT.
- 6.8. Courses must meet the number of hours sufficient to meet the stated performance objectives as outlined in the course outlines provided to the SCHOOL DISTRICT on a semester basis.
 - 6.9. Courses offered at the SCHOOL DISTRICT as part of this CCAP Agreement shall be of the same quality and rigor as those offered on the COLLEGE campus and shall be in compliance with COLLEGE academic standards.
 - 6.10. Courses offered as part of this CCAP Agreement will comply with all applicable regulations, policies, procedures, prerequisites, and standards applicable to the COLLEGE as well as any corresponding policies, practices, and requirements of the SCHOOL DISTRICT. In the event of a conflict between the COLLEGE course related regulations, policies, procedures, prerequisites and standards and SCHOOL DISTRICT policies, practices and requirements, the COLLEGE regulations, policies, procedures, prerequisites, and standards, shall prevail.
 - 6.11. A student's withdrawal prior to completion of a course offered as part of this CCAP Agreement shall be in accordance with COLLEGE guidelines, policies, pertinent statutes and regulations.
 - 6.12. Supervision and evaluation of students enrolled in courses offered as part of this CCAP Agreement shall be in accordance with COLLEGE guidelines, policies, pertinent statutes and regulations.
 - 6.13. COLLEGE has the sole right to control and direct the instructional activities for all CCAP Agreement courses and all instructors, including those who are SCHOOL DISTRICT employees.
 - 6.14. This CCAP Agreement certifies that any remedial course taught by community college faculty at a partnering high school campus shall be offered only to high school students who do not meet their grade level standard in math, English, or both on an interim assessment in grade 10 or 11, as determined by the partnering SCHOOL DISTRICT, and shall involve collaborative effort between the SCHOOL DISTRICT and the COLLEGE faculty to deliver an innovative remediation course as an intervention in the student's junior or senior year to ensure the student is prepared for college-level work upon graduation.
 - 6.15. CCAP Agreement Courses outlined in Appendix C shall be updated annually and approved before the start of each academic year.

7. INSTRUCTORS

- 7.1. All instructors teaching COLLEGE courses offered as part of this CCAP Agreement must meet the minimum qualifications for instruction in a California community college as set forth in Title 5 California Code of Regulations, Sections 53410 and 58060 or as amended.
- 7.2. The CCAP Agreement Appendix C shall specify which participating SCHOOL DISTRICT or COLLEGE will be the employer of record for purposes of assignment monitoring and reporting to the county office of education.
- 7.3. This CCAP Agreement specifies that the SCHOOL DISTRICT will assume reporting

responsibilities pursuant to applicable federal teacher quality mandates.

- 7.4. Instructors who teach COLLEGE courses offered as part of this CCAP Agreement must provide the supervision and control reasonably necessary for the protection of the health and safety of students and may not have any other assigned duty during the instructional activity.
- 7.5. Instructors who teach COLLEGE courses shall comply with the fingerprinting requirements set forth in Education Code section 45125 or as amended and the tuberculosis testing and risk assessment requirements of California Health and Safety Code section 121525 or as amended. In addition to any other prohibition or provision, no person who has been convicted of a violent or serious felony shall be eligible to teach any courses offered as part of this CCAP Agreement or otherwise provide services on a SCHOOL DISTRICT site. SCHOOL DISTRICT shall immediately notify COLLEGE if an instructor is charged with an offense prohibited by Education Code sections 44010 or 44011.
- 7.6. Prior to teaching, faculty provided by the SCHOOL DISTRICT shall participate in required discipline-specific training and orientation from COLLEGE regarding, but not limited to, course curriculum, assessment criteria, pedagogy, course philosophy, testing and grading procedures record keeping, and other instructional responsibilities. Such training shall be approved and provided by the COLLEGE.
- 7.7. Prior to teaching, instructors provided by the COLLEGE may receive training and orientation from SCHOOL DISTRICT regarding, but not limited to, SCHOOL DISTRICT policies, practices, and requirements. Such training may be approved and provided by the SCHOOL DISTRICT.
- 7.8. Faculty provided by the SCHOOL DISTRICT are eligible to participate in professional development activities sponsored by the COLLEGE as required by the terms and condition of the contract and shall be encouraged to participate in ongoing collegial interaction to include, but not limited to, addressing course content, course delivery, assessment, evaluation, and/or research and development in the field.
- 7.9. The COLLEGE shall evaluate faculty performance for the college courses using the adopted evaluation of process and standards for faculty of the COLLEGE, subject to the approval of COLLEGE.
- 7.10. The COLLEGE and SCHOOL DISTRICT will work collaboratively to identify instructors from SCHOOL DISTRICT who may meet minimum qualification requirements or local equivalency standards to teach a COLLEGE course and encourage them to apply for consideration. Instructors will be required to go through the COLLEGE screening process for possible selection and assignment to the course.
- 7.11. The SCHOOL DISTRICT teachers approved to teach COLLEGE courses remain employees of the SCHOOL DISTRICT, subject to the authority of the SCHOOL DISTRICT, but will also be subject to the authority of COLLEGE specifically with regard to their duties as COLLEGE instructors, pursuant to the terms of Appendix A.
- 7.12. The COLLEGE shall determine the number of instructors, the ratio of instructors to students, and the subject areas of instruction.
- 7.13. Faculty provided by the SCHOOL DISTRICT who do not comply with the policies, regulations, standards, and expectations of the COLLEGE shall be ineligible to teach college courses under this CCAP Agreement.
- 7.14. SCHOOL DISTRICT teachers approved to teach CCAP Courses under this CCAP

Agreement must submit grades to both the COLLEGE and SCHOOL DISTRICT using the COLLEGE student information system by the established timeline (Appendix D).

- 7.15. SCHOOL DISTRICT teachers approved by the COLLEGE shall sign an Agreement with the Instructor (Appendix A) prior to the start of each academic year.
- 7.16. SCHOOL DISTRICT teachers approved by the COLLEGE shall provide support to high school students taking COLLEGE courses under CCAP agreement with COLLEGE admission and registration procedures.

8. ASSESSMENT OF LEARNING AND CONDUCT

- 8.1. Students enrolled in COLLEGE courses offered as part of this CCAP Agreement at the SCHOOL DISTRICT shall be held to the same standards of achievement as students in courses taught on the COLLEGE campus.
- 8.2. Students enrolled in COLLEGE courses offered as part of this CCAP Agreement at the SCHOOL DISTRICT shall be held to the same grading standards as those expected of students in courses taught on the COLLEGE campus.
- 8.3. Students enrolled in COLLEGE courses offered as part of this CCAP Agreement at the SCHOOL DISTRICT shall be assessed using the same methods (e.g., papers, portfolios, quizzes, labs, etc.) as students in courses taught on the COLLEGE campus.
- 8.4. Students enrolled in COLLEGE courses offered as part of this CCAP Agreement at the SCHOOL DISTRICT shall be held to the same behavioral standards as those expected of students in courses taught on the COLLEGE campus.

9. LIAISON AND COORDINATION OF RESPONSIBILITIES

- 9.1. The COLLEGE shall appoint an educational administrator who will serve as point of contact to facilitate coordination and cooperation between COLLEGE, SCHOOL DISTRICT, and HIGH SCHOOL in conformity with COLLEGE policies and standards. (Ed. Code, § 76004, subd. (c)(2).) Among other things, the COMMUNITY COLLEGE DISTRICT Educational Administrator and the SCHOOL DISTRICT Educational Administrator described in Section 9.2, shall collaborate to determine the process for timely receiving, investigating, and remediating complaints of sexual misconduct or other conduct covered by Title IX of the Education Amendments of 1972 alleged to have occurred in or related to the CCAP program.
- 9.2. The SCHOOL DISTRICT shall appoint an educational administrator who will serve as point of contact to facilitate coordination and cooperation between SCHOOL DISTRICT, COLLEGE, HIGH SCHOOL in conformity with SCHOOL DISTRICT policies and standards.
- 9.3. This CCAP Agreement requires an annual report to the office of the Chancellor of the California Community Colleges by COLLEGE and SCHOOL DISTRICT. COLLEGE shall complete and file the Apportionment Attendance Report (CCFS-320); SCHOOL DISTRICT agrees to provide the following information, when requested by COLLEGE, in accordance with AB 288 Section 2, Education Code Section 76004:
 - a. The total number of high school students by school site enrolled in each partnership, aggregated by gender and ethnicity, and reported in compliance with all applicable state and federal privacy laws.

- b. The total number of community college courses by course category and type and by school site enrolled in by CCAP partnership participants.
- c. The total number and percentage of successful course completions, by course category and type and by school site, of CCAP partnership participants.
- d. The total number of full-time equivalent students generated by CCAP partnership community college district participants.

10. DISPUTES

10.1. COLLEGE and SCHOOL DISTRICT recognize that, from time to time, disputes may arise between COLLEGE employees or students and SCHOOL DISTRICT employees or students. When such disputes arise, COLLEGE and SCHOOL DISTRICT shall collaborate and use their best efforts to resolve them informally. Where informal resolution is not successful or the PARTIES must address a formal inter-agency complaint, the following process will be utilized to resolve the matter.

- a. The PARTY receiving the complaint will timely notify the other, and promptly provide the other PARTY with any written complaint received.
- b. The Educational Administrators will review the complaint to determine, based on the nature of the complaint, whether any statutory or regulatory timelines or other procedural requirements apply, including but not limited to:
 - 10.1.b.1. Whether COLLEGE is required to investigate the complaint to the State Chancellor pursuant to Title 5 of the California Code of Regulations.
 - 10.1.b.2. Whether, based on the nature of the complaint, the complainant is entitled to any rights or protections with regard to how the complaint is handled, pursuant to Title 5 or applicable state or federal laws, including but not limited to Title IX of the Education Amendments of 1972.
 - 10.1.b.3. If either Educational Administrator finds such rights to exist, he or she shall notify the other Educational Administrator, and COLLEGE and SCHOOL DISTRICT shall cooperate as needed in carrying out these requirements. It is understood that such requirements may include but are not limited to conducting a formal investigation within regulatory timelines or the implementation of interim safety measures for the complainant.
- c. Within a reasonable time, either PARTY receiving the complaint, the PARTIES will discuss the nature and severity of the allegations and come to a mutual agreement regarding the need for and scope of any investigation required. If it is agreed that a formal investigation is required, the PARTIES will mutually agree upon an investigator, who may be an outside investigator, or qualified employee of COLLEGE or SCHOOL DISTRICT. If the PARTIES agree to have the matter investigated internally by either a COLLEGE or SCHOOL DISTRICT employee, the other PARTY may designate an employee to attend all witness interviews. Where it is determined that an outside investigator will be used, the cost will be divided between the PARTIES.
- d. If, despite the good faith effort of the PARTIES, they are unable to agree on a process for investigating the complaint, the PARTY whose employee/student is the subject of the complaint will determine the process.

- e. The COLLEGE and SCHOOL DISTRICT will cooperate in any investigation initiated and make its employees available to the investigator.
- f. Interviews of COLLEGE and SCHOOL DISTRICT employees shall comply with any rights and protections afforded to them under an applicable collective bargaining agreement or state or federal law, including but not limited to the right to have a representative present during an interview that could lead to discipline.
- g. The investigator will prepare a report that will be provided to both PARTIES setting forth findings as to the allegations and the basis for the findings.
- h. The COLLEGE and SCHOOL DISTRICT shall share any and all materials from the investigation, unless sharing would cause a PARTY to violate confidentiality or privacy laws.
- i. The COLLEGE and SCHOOL DISTRICT have sole discretion in determining any disciplinary measures to be imposed against their respective employees or students.
- j. Regardless of any disciplinary measures taken by the COLLEGE or SCHOOL DISTRICT against its respective employees or students, the other PARTY retains the right to have the subject of a sustained complaint removed from participating in or providing services for the program that is the subject of this CCAP Agreement.

11. APPORTIONMENT

- 11.1. COLLEGE shall include the students enrolled in a CCAP Agreement course in its report of full-time equivalent students (FTES) for purposes of receiving state apportionments when the course(s) complies with current requirements for dual enrollment under applicable California law.
- 11.2. For purposes of allowances and apportionments from Section B of the State School Fund, a community college district conducting a closed course on a high school campus shall be credited with those units of full-time equivalent students attributable to the attendance of eligible high school pupils.
- 11.3. The COLLEGE shall not receive a state allowance or apportionment for an instructional activity for which the SCHOOL DISTRICT has been, or shall be, paid an allowance or apportionment. (Ed. Code § 76004, subdivision (o)(2)).
- 11.4. The attendance of a SCHOOL DISTRICT pupil at the COLLEGE as a special part-time or full-time student pursuant to this section is authorized attendance for which the COLLEGE shall be credited or reimbursed pursuant to Section 48802 or 76002, provided that no school district has received reimbursement for the same instructional activity.

12. CERTIFICATIONS

- 12.1. The SCHOOL DISTRICT certifies that:
 - a. The direct education costs of the courses offered as part of this CCAP Agreement are not fully funded through other sources.
 - b. It agrees and acknowledges that the COLLEGE will claim apportionment for the SCHOOL DISTRICT students enrolled in community college course(s) under this CCAP Agreement.

- c. Any COLLEGE instructor teaching a course at the SCHOOL DISTRICT has not displaced or resulted in the termination of an existing high school teacher teaching the same course on that high school campus.

12.2. The COLLEGE certifies that:

- a. A community college course offered for college credit at the participating SCHOOL DISTRICT does not reduce access to the same course offered at the partnering COLLEGE.
- b. The COLLEGE has not received full compensation for the direct education costs for the conduct of the courses offered as part of this CCAP Agreement from other sources.
- c. The Agreement is consistent with the core mission of the COLLEGE pursuant to Section 66010.4 and students participating in this CCAP Agreement will not lead to displacement of otherwise eligible adults at the COLLEGE.
- d. A qualified SCHOOL DISTRICT instructor teaching a course offered for college credit at a high school campus has not displaced or resulted in the termination of an existing COLLEGE faculty member teaching the same course at the partnering community college campus.

12.3. The PARTIES certify that:

- a. Any COLLEGE instructor teaching a course on a SCHOOL DISTRICT campus has not been convicted of any sex offense as defined in Education Code section 44010 or as amended, or any controlled substance offense as defined in Education Code section 44011 or as amended.
- b. The SCHOOL DISTRICT and COLLEGE comply with local collective bargaining agreements and all state and federal reporting requirements regarding the qualifications of the teacher or faculty member teaching a CCAP Agreement course offered for high school credit. (AB288 Sec. 2 (I).)

13. PROGRAM IMPROVEMENT

- 13.1. The COLLEGE and the SCHOOL DISTRICT may annually conduct surveys of participating SCHOOL DISTRICT pupils, instructors, principals, and school counselors for the purpose of informing practice, adjusting, and improving the quality of courses offered as part of this CCAP Agreement.

14. RECORDS

- 14.1. Permanent records of student attendance, grades and achievement will be maintained by both the SCHOOL DISTRICT and COLLEGE for SCHOOL DISTRICT students who enroll in course(s) offered as part of this CCAP Agreement. Permanent records of student enrollment, grades, and achievement for COLLEGE students shall be maintained by COLLEGE.
- 14.2. Each PARTY shall maintain records pertaining to this CCAP Agreement as may be required by federal and state law. Each PARTY may review and obtain a copy of the other

PARTY'S pertinent records subject to federal and state privacy statutes.

- 14.3. SCHOOL DISTRICT instructors will submit grades to the COLLEGE when due according to the COLLEGE schedule per section 7.14. The SCHOOL DISTRICT will include all criteria identified by the COLLEGE for grading purposes.
- 14.4. COLLEGE may provide the SCHOOL DISTRICT with a report on participating students' final grades after each term.

15. CCAP AGREEMENT DATA MATCH AND REPORTING

- 15.1. COLLEGE and SCHOOL DISTRICT shall ensure operational protocols consistent with the collection of participating student data and the timely submission of the data.
- 15.2. COLLEGE shall report all program and participating student data to the office of the Chancellor of the California Community Colleges.

16. DATA SHARING

- 16.1. COLLEGE and SCHOOL DISTRICT may share confidential student data for the purposes of evaluating the educational services provided under this CCAP agreement and for evaluating student performance pursuant to participating in CCAP courses. Any data shared will be for research and analytical purposes aimed at understanding student performance and improving applicable federal and state laws concerning access to and confidentiality of student record information as described in Section 17 of this agreement.

17. PRIVACY OF STUDENT RECORDS

- 17.1. COLLEGE and SCHOOL DISTRICT understand and agree that education records of students enrolled in a CCAP course and personally identifiable information contained in those educational records are subject to the Family Educational Rights and Privacy Act (FERPA) 20 U.S.C. § 1232g; 34 C.F.R. Part 99, including the disclosure provisions of § 99.30 and state law as outlined in Education Code section 49064 and section 49076). COLLEGE and SCHOOL DISTRICT agree to hold all student education records generated pursuant to this CCAP Agreement in strict confidence and further agree not to disclose such records except as authorized by applicable law or regulation for COLLEGE records or by the parent or guardian's prior written consent for HIGH SCHOOL records. (34 C.F.R. § 99.33 (a), (b); 34 C.F.R. § 99.34(b) and Education Code §§ 49064 and 49076.)
- 17.2. **Limitation on Use.** COLLEGE and SCHOOL DISTRICT shall use each student education record that they may receive pursuant to this CCAP Agreement solely for purposes consistent with their authority to access that information pursuant to Federal and State law, as may be as applicable. (34 C.F.R. § 99.31, 34 C.F.R. § 99.34, and Education Code § 49076.)
- 17.3. **Recordkeeping Requirements.** COLLEGE and SCHOOL DISTRICT shall comply with the requirements governing maintenance of records of each request for access to and each disclosure of student education records set forth under Title 34, Code of Federal Regulations § 99.32 and under Education Code § 49064 as applicable.
- 17.4. **Acknowledgement of Receipt of Notice of FERPA Regulations.** By signature of its authorized representative or agent on this Agreement, COLLEGE and SCHOOL DISTRICT hereby acknowledges that it has been provided with the notice required under

34 C.F.R. § 99.33(d) that it is strictly prohibited from re-disclosing student education records to any other person or entity except as authorized by applicable law or regulation. Parent or guardian requests for information will need to be addressed directly by the HIGH SCHOOL or SCHOOL DISTRICT personnel.

18. REIMBURSEMENT

18.1. The SCHOOL DISTRICT shall invoice the COLLEGE no later than 30 (thirty) days after the start of each term for the instructional services provided through this CCAP agreement as follows:

- a. For courses taught by COLLEGE-approved SCHOOL DISTRICT teachers and COLLEGE instructors on HIGH SCHOOL campuses during regular high school hours rendered at the rate of \$1,000.00 per course unit delivered to CCAP students.

Example: 3 CCAP courses @ 3 units each = 9 units x \$1,000.00 = \$9,000.00

18.2. The COLLEGE shall make payment to the SCHOOL DISTRICT within 30 days of receiving the invoice for instructional services rendered.

18.3. The COLLEGE is required to report to the state the percentage of funds paid to an agency to the SCHOOL DISTRICT that will provide direct instruction on behalf of the college as part of the CCAP partnership agreement. The SCHOOL DISTRICT will use 100% of all funds received from Allan Hancock College in fulfillment of this agreement to pay for direct instructional costs. (Ed. Code § 84632).

19. FACILITIES

19.1. The SCHOOL DISTRICT will provide adequate classroom space at its facilities or other mutually agreed upon locations to conduct the instruction and do so without charge to COLLEGE or students. SCHOOL DISTRICT agrees to clean, maintain, and safeguard SCHOOL DISTRICT's premises. SCHOOL DISTRICT warrants that its facilities are safe and compliant with all applicable buildings, fire, and safety codes.

19.2. The SCHOOL DISTRICT will furnish, at its own expense, all course materials, specialized equipment, books and other necessary equipment for all SCHOOL DISTRICT students. The parties understand that such equipment and materials are the SCHOOL DISTRICT's sole property.

19.3. The SCHOOL DISTRICT facilities may be used by COLLEGE for COLLEGE course offerings before or after regular high school schedule at no additional cost. Prior approval by the SCHOOL DISTRICT is required. COLLEGE courses offered before or after the regular high school schedule will be open to the public.

20. INDEMNIFICATION

20.1. The SCHOOL DISTRICT agrees to and shall indemnify, save and hold harmless the COLLEGE, and its governing board, officers, employees, administrators, independent contractors, subcontractors, agents and other representatives from any and all claims,

demands, liabilities, costs, expenses, damages, causes of action, losses, and judgments, arising out of SCHOOL DISTRICT's performance of this CCAP Agreement. The obligation to indemnify shall extend to all claims and losses that arise out of SCHOOL DISTRICT's or its trustees', officers', agents', or employees' negligence, wrongful acts or omissions, or willful misconduct related to this CCAP Agreement or performance of this CCAP Agreement. The provisions of this section shall survive the termination or expiration of this CCAP Agreement.

20.2. The COLLEGE agrees to and shall indemnify, save and hold harmless the SCHOOL DISTRICT and its governing board, officers, employees, administrators, independent contractors, subcontractors, agents and other representatives from any and all claims, demands, liabilities, costs, expenses, damages, causes of action, losses, and judgments, arising out of COLLEGE'S performance of this CCAP Agreement. The obligation to indemnify shall extend to all claims and losses that arise out of COLLEGE'S or its trustees', officers', agents', or employees' negligence, wrongful acts or omissions, or willful misconduct related to this CCAP Agreement or performance of this CCAP Agreement. The provisions of this section shall survive the termination or expiration of this CCAP Agreement.

21. INSURANCE

21.1. The SCHOOL DISTRICT, in order to protect the COLLEGE, its agents, employees and officers against claims and liability for death, injury, loss and damage arising out of or in any manner connected with the performance and operation of the terms of this CCAP Agreement, shall secure and maintain in force during the entire term of this CCAP Agreement, insurance coverage or an approved program of self-insurance in the amount of not less than ONE MILLION DOLLARS (\$1,000,000) per incident and TWO MILLION DOLLARS (\$2,000,000) general aggregate for personal injury, bodily injury, death, and property and other damage, with an admitted California insurer duly licensed to engage in the business of insurance in the State of California, or public entity risk management Joint Powers Authority, authorized to provide public liability and property damage insurance in the state of California. Said policy of insurance, insurance coverage through a public entity risk management JPA, or program of self-insurance shall expressly name the COLLEGE, its agents, employees and officers as an additional insured for the purposes of this CCAP Agreement. A certificate of insurance including such endorsement shall be furnished to the COLLEGE.

21.2. The COLLEGE, in order to protect the SCHOOL DISTRICT, its agents, employees and officers against claims and liability for death, injury, loss and damage arising out of or in any manner connected with the performance and operation of the terms of this CCAP Agreement, shall secure and maintain in force during the entire term of this CCAP Agreement, insurance coverage or an approved program of self-insurance in the amount of not less than ONE MILLION DOLLARS (\$1,000,000) per incident and TWO MILLION DOLLARS (\$2,000,000) general aggregate for personal injury, bodily injury, death, and property and other damage, with an admitted California insurer duly licensed to engage in the business of insurance in the State of California, or public entity risk management Joint Powers Authority, authorized to provide public liability and property damage insurance in the State of California. Said policy of insurance, insurance coverage through a public entity risk

management JPA or program of self-insurance shall expressly name the SCHOOL DISTRICT, its agents, employees and officers as an additional insured for the purposes of this CCAP Agreement. A certificate of insurance including such endorsement shall be furnished to the SCHOOL DISTRICT.

- 21.3. For the purpose of Workers' Compensation, SCHOOL DISTRICT shall be the "primary employer" for all its employees who perform services as instructors and support staff. SCHOOL DISTRICT shall be solely responsible for processing, investigating, defending, and paying all workers' compensation claims by their respective SCHOOL DISTRICT employees made in connection with performing services and receiving instruction under this CCAP Agreement. SCHOOL DISTRICT agrees to hold harmless, indemnify, and defend COLLEGE, its directors, officers, agents, and employees from any liability resulting from its failure to process, investigate, defend, or pay any workers' compensation claims by SCHOOL DISTRICT employees connected with providing services under this CCAP Agreement.

22. NON-DISCRIMINATION

- 22.1. Neither the SCHOOL DISTRICT nor the COLLEGE shall discriminate on the basis of race or ethnicity, gender, nationality, physical or mental disability, sexual orientation, religion, or any other protected class under California State or federal law.

23. NOTICES

- 23.1. Any and all notices required to be given hereunder shall be deemed given when personally delivered or deposited in the U.S. Mail, postage to be prepaid, to the following addresses:

Allan Hancock College Joint Community College District
800 S. College Drive
Santa Maria, CA 93460
Attn: Dennis Curran

Brawley Union School District
Address: 480 N Imperial Ave, Brawley, CA 92227
Attn: Jonine Trevino

24. MODIFICATION AND AMENDMENT

- 24.1. Appendix A through D to this CCAP Agreement is incorporated by this reference into this CCAP Agreement.
- 24.2. This CCAP Agreement and Appendix A through D to this CCAP Agreement set forth the entire agreement between the PARTIES relating to the subject matter of this CCAP Agreement. This CCAP Agreement and Appendix A through D to this CCAP Agreement supersede any prior agreements, promises, negotiations, or representations, express or implied, oral or written, not included in this CCAP Agreement and Appendix A through D to this CCAP Agreement.

24.3. This Agreement may be amended only with the mutual consent of the Parties. All amendments must be in writing and must be approved by the Parties' respective governing Boards.

25. GOVERNING LAWS

25.1. This CCAP Agreement will be governed by and construed in accordance with California law, and the venue of any action or proceeding in connection with this CCAP Agreement shall be Santa Barbara County, California.

26. COMMUNITY COLLEGE DISTRICT BOUNDARIES

26.1. For locations outside the geographical boundaries of Allan Hancock College Joint Community College District, the COLLEGE will comply with the requirements of Title 5 of the California Code of Regulations, Sections 55300 et seq. or as amended, concerning approval by adjoining high school or community college districts and use of non-district facilities.

27. SEVERABILITY

27.1. This CCAP Agreement shall be considered severable, such that if any provision or part of the CCAP Agreement is ever held invalid under any law or ruling, that provision or part of the CCAP Agreement shall remain in force and effect to the extent allowed by law, and all other provisions or parts shall remain in full force and effect.

28. COUNTERPARTS

28.1. This CCAP Agreement may be executed by the PARTIES in separate counterparts, each of which when so executed and delivered shall be an original, but all such counterparts shall together constitute one and the same instrument.

IN WITNESS WHEREOF, the PARTIES hereto have caused this CCAP Agreement to be executed on the dates set forth below, to be effective as of the Effective Date.

ALLAN HANCOCK JOINT COMMUNITY
COLLEGE DISTRICT

BRAWLEY UNION SCHOOL DISTRICT

By: _____
Dennis Curran
Associate Superintendent/Vice President of
Finance and Administration

By: _____
Simon R Canalez
Superintendent

Date: _____

Date: _____

ALLAN HANCOCK JOINT COMMUNITY
COLLEGE DISTRICT BOARD MEETINGS

BRAWLEY UNION SCHOOL DISTRICT
BOARD MEETINGS

Information Board Meeting Date:

Information Board Meeting Date:

Public Comment
and Approval Board Meeting Date:

Public Comment
and Approval Board Meeting Date:

APPENDIX A

ALLAN HANCOCK COLLEGE JOINT COMMUNITY COLLEGE DISTRICT

Agreement with INSTRUCTOR

This agreement is made and entered into this _____ [day] of _____ [month] ____ [year] by three parties: The Allan Hancock College Joint Community College District (hereinafter “COLLEGE”), the _____ [high school district] (hereinafter “SCHOOL DISTRICT”) and _____ [first name, last name], an employee of the SCHOOL DISTRICT (hereinafter “INSTRUCTOR”) who is being assigned to the COLLEGE on a part-time basis pursuant to Title 5, California Code of Regulations, section 58058(b).

WHEREAS, the SCHOOL DISTRICT has the experience, training, equipment and other resources, and staff necessary to provide instruction to COLLEGE students through the CCAP Agreement;

WHEREAS, Title 5, California Code of Regulations, section 58050, subdivision (a) provides authority for claiming apportionment;

NOW, THEREFORE, the three parties to this Agreement hereby agree as follows:

1. The SCHOOL DISTRICT’s INSTRUCTOR is an employee of the SCHOOL DISTRICT who shall meet “Minimum Qualifications” for the academic position of COLLEGE’s INSTRUCTOR as established by the COLLEGE and as determined by the COLLEGE.
2. The SCHOOL DISTRICT’s INSTRUCTOR is professionally and specially trained and competent to provide the supervisory and/or instructional services required by the COLLEGE.
3. The INSTRUCTOR will be an employee of the COLLEGE for purposes of the Attendance Accounting Standards (Ed. Code, § 58050). COLLEGE has the right to; 1) evaluate and terminate INSTRUCTOR; 2) evaluate the quality of instruction to ensure that it meets the needs of students; 3) evaluate the quality and rigor equal to the COLLEGE’S approved course outline of record and the accreditation requirements of COLLEGE. The COLLEGE will not provide INSTRUCTOR evaluation results to the SCHOOL DISTRICT.
4. The SCHOOL DISTRICT’s INSTRUCTOR shall at all times comply with the supervisory and/or instructional requirements outlined in Title 5, California Code of Regulations, section 58055, which require direct instruction by the SCHOOL DISTRICT’s INSTRUCTOR except in limited circumstances. The SCHOOL DISTRICT’s INSTRUCTOR’s responsibilities and duties as an employee of the COLLEGE shall include, but are not limited to, the following:
 - 4.1. Ensure that an instructional time of 50 minutes per class each day is expended in full compliance with the course objectives determined by the COLLEGE.
 - 4.2. Ensure the safety and well-being of students.
 - 4.3. Be in sufficient physical proximity and range of communication to provide immediate instructional supervision and control of all students in his/her classes.
 - 4.4. Attend periodic staff meetings with the COLLEGE.
 - 4.5. Regularly check and respond to communication from COLLEGE.
 - 4.6. Priority in class enrollment shall be given to students desiring to take the course for college credit towards a degree or certificate (Ed. Code § 76370). Ensure accurate and current daily student attendance records, accurate calculation of final student grades of

all students enrolled in the course for college credit, and the prompt submission of all data necessary for the calculation of FTES to the DISTRICT within 3 (three) calendar days of course completion (Ed. Code § 84500).

- 4.7. Ensure the effective use of instructional methods, technology, testing and remediation.
 - 4.8. Ensure that he/she does not have any other assigned duties during the instructional activity where multiple skill levels of students are being taught for which attendance is being claimed.
 - 4.9. Be familiar with and comply with all relevant COLLEGE policies, rules and regulations, including but not limited, to those related to student safety, grading, attendance, sexual harassment and discrimination.
 - 4.10. Provide support to SCHOOL DISTRICT students taking COLLEGE courses under CCAP agreement with COLLEGE admission and registration procedures.
5. The SCHOOL DISTRICT shall indemnify and hold harmless the COLLEGE and its authorized agents, officers, and employees against any and all claims and actions arising from the SCHOOL DISTRICT's INSTRUCTOR's or SCHOOL DISTRICT's negligent, reckless or intentional acts, errors or omissions and for any cost or expense incurred by the COLLEGE on account of any claim therefor.
 6. The COLLEGE shall provide no compensation to the SCHOOL DISTRICT's INSTRUCTOR for any services rendered pursuant to this Agreement, but compensation, as well as workers' compensation insurance, shall be the responsibility of the SCHOOL DISTRICT in accordance with its established and standard practices.
 7. This Agreement may be terminated at any time by the COLLEGE within the sole and exclusive discretion of the COLLEGE upon written notice to the SCHOOL DISTRICT and the SCHOOL DISTRICT's INSTRUCTOR. This Agreement may be terminated upon thirty (30) days' prior written notice to COLLEGE by either the SCHOOL DISTRICT or the SCHOOL DISTRICT's INSTRUCTOR within either's sole and exclusive discretion.

IN WITNESS WHEREOF, the parties hereto have executed this Agreement the day and year last written below.

INSTRUCTOR

ALLAN HANCOCK COLLEGE JOINT
COMMUNITY COLLEGE DISTRICT

Print

Print

Signature

Signature

APPENDIX B

Identification of CCAP Pathways for Course-Specific College and Career Pathway Opportunities

Pursuant to California Assembly Bill No. 288, the COLLEGE and SCHOOL DISTRICT enter into this partnership agreement to offer College and Career Pathways (CCAP) to high school students to expand dual enrollment opportunities to facilitate college and career readiness, particularly among students who may not already be college-bound or who are underrepresented in higher education.

The goal of the CCAP partnership is to offer seamless pathways from high school to community college to promote: 1) academic preparation for transfer to four-year colleges and universities; 2) completion of career and technical education programs for entry into the workforce; (3) improving high school graduation rates, and (4) helping high school pupils achieve college and career readiness.

The following pathways are included in the CCAP partnership agreement between the COLLEGE and SCHOOL DISTRICT:

Career and Technical Education:

1. This pathway includes COLLEGE courses in a Career and Technical education (“CTE”) pathway at the college level that apply to an Allan Hancock College degree or certificate in the pathway. This includes:
 - a. Naming of HIGH SCHOOL Pathway and Course Location in Sequence (Introductory, Concentrator, Capstone, or Practicum)
 - b. Naming of COLLEGE Pathway – Degree or Certificate
 - c. Identifying Career/Employment Outcomes associated with CTE Pathway
 - d. Identifying the course(s) in the Pathway to be offered under the CCAP Agreement.
2. Examples of CTE Technical Pathways include Automotive, Digital Art and Graphic Design, Culinary, Early Childhood Studies, Welding etc.

College and Career Readiness:

1. This pathway includes COLLEGE courses in career exploration and career development that prepare students in college and career planning. Successful completion of these courses will allow students to matriculate at college level in courses in a CTE pathway or General Education/ California State University (“CSU”) Transfer pathway.
2. Course examples include: WEE (Work Experience); PD (Career Planning).

Preparation for Transfer:

1. California General Education Transfer Curriculum (Cal-GETC). This pathway includes COLLEGE courses which have been approved to meet the lower-division general education requirements at any CSU or University of California campus (i.e. Areas 1-6)

Improve High School Graduation Rates:

1. Student participation in college courses improves graduation rates of students who participate compared to peers who do not participate in college-level coursework.

APPENDIX C

CCAP Agreement Courses Approved for 2025-26

HIGH SCHOOL DISTRICT:

Brawley Union School District

HIGH SCHOOL SITE / LOCATION: 480 North Imperial Ave., Brawley, CA 92227

PROJECTED NUMBER OF STUDENTS TO BE SERVED: 350

TOTAL PROJECTED FTES: 36.00

CCAP Pathway	College Degree or Certificate	High School Pathway	CCAP Course Offerings		Number of Sections, High School period(s) & Times		Instructor Name & Employer of Record (AHC or HS)		Projected Number of Students	Projected FTES
			FALL	SPRING	FALL	SPRING	FALL	SPRING		
College & Career Readiness	AA GE	CTE Education	Freshmen Seminar (HS)	PROD 301	Freshmen Seminar (HS)	10	Dr. Lizbeth Pirrie	Dr. Lizbeth Pirrie	350	36.00
							Mr. Brandin Young (HS)	Mr. Brandin Young (HS)		

1. **REQUIRED:** Describe the criteria used to assess the ability of pupils to benefit from the course(s) offered:

In consultation with their SCHOOL DISTRICT counselors, students self-select a pathway based on their academic readiness and alignment of course content to students' educational and career goals. SCHOOL DISTRICT and COLLEGE faculty identified CCAP courses using the following criteria:

- a. Alignment with HIGH SCHOOL pathways and COLLEGE programs of study.
- b. Potential for course completion to accelerate students' time to completion of postsecondary degree or certificate.
- c. Potential to earn a Certificate of Training and be eligible to enter the workforce in their selected career technical pathway.
- d. Potential to work toward completion of an associate degree or an associate degree for transfer.

2. **MINIMUM QUALIFICATIONS FOR INSTRUCTION:** All instructors teaching CCAP Agreement Courses must meet the minimum qualifications for instruction in a California community college as set forth in Title 5 of the California Code of Regulations, sections 53410 and 58060 or as amended. The minimum qualifications for instruction are:

Course Name & Number	Minimum Qualifications For Instructors
PROD 301	<ul style="list-style-type: none"> • Master's degree in counseling, rehabilitation counseling, clinical psychology, counseling psychology, guidance counseling, educational counseling, social work, career development, marriage and family therapy, or marriage, family, and child counseling • OR the equivalent <p>NOTE: A bachelor's degree in one of the listed degrees and a license as a Marriage and Family Therapist (MFT) is an alternative qualification for this discipline</p> <ul style="list-style-type: none"> • OR master's degree in education • OR any bachelor's degree or higher and two years of professional experience in Office Technologies • OR any associate degree and six years of professional experience in Office Technologies. <p>NOTE: Professional experience is required when the application possesses a master's degree. The professional experience required must be directly related to the teaching assignment.</p>

3. **BOOKS AND INSTRUCTIONAL MATERIALS:** The total cost of books and instructional materials for SCHOOL DISTRICT students participating in CCAP course as part of this CCAP Agreement will be borne by SCHOOL DISTRICT. The cost estimate is based on the current pricing and additions.

COURSE NAME & NUMBER	TEXTBOOK	COST	OTHER INSTRUCTIONAL MATERIALS	COST
PROD 301	Career Choices and Changes, M. Bingham, S. Stryker, 6 th Edition (2019)	\$59.95	My10yearPlan.com	\$35

4. **JOINT FACILITIES USE PROTOCOLS:** COLLEGE and SCHOOL DISTRICT shall adhere to the terms and protocols outlined in Section 19, Facilities, of the CCAP Agreement. SCHOOL DISTRICT, shall extend access and use of the following SCHOOL DISTRICT facilities:

BUILDING NAME & ADDRESS	CLASSROOM	DAYS	HOURS
Brawley Union High School 480 N Imperial Avenue Brawley, CA 92227	49 & 28	Monday, Tuesday, Wednesday, Thursday, Friday	8:00 am – 3:01 pm (100 minute class periods)

ALLAN HANCOCK JOINT COMMUNITY COLLEGE DISTRICT

BRAWLEY UNION HIGH SCHOOL

By: _____
 Dr. Robert Curry
 Associate Superintendent/Vice-President, Academic Affairs

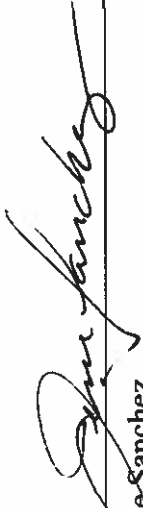
By: 
 Jesse Sanchez,
 Brawley Union High School Principal

Date: _____

Date: 5/5/2025

ALLAN HANCOCK JOINT COMMUNITY COLLEGE DISTRICT BOARD MEETINGS

BRAWLEY UNION SCHOOL DISTRICT BOARD MEETINGS

Information Board Meeting Date: _____

Information Board Meeting Date:
 June 11, 2025

Public Comment

Public Comment

and Approval Board Meeting Date:

and Approval Board Meeting Date:

June 25, 2025

APPENDIX D Registration Timeline 2025 - 2026

2025-2026 Week Ranges	Process	Timeline	Type
Week 1: July 1, 2025 - July 7, 2025			
Week 2: July 8, 2025 - July 14, 2025			
Week 3: July 15, 2025 - July 21, 2025			
Week 4: July 22, 2025 - July 28, 2025			
Week 5: July 29, 2025 - August 4, 2025	Ideal	CRNs available for DualEnroll & we see bulk of forms (Would like Aug 1 deadline for CRNs)	CCAP
Week 6: August 5, 2025 - August 11, 2025	Ideal	(NonCCAP) Late Add influx, Appeal Delays, Registration Processing Delays	
Week 6: August 5, 2025 - August 11, 2025	Ideal	Firm Deadline for NonCCAP Petitions (Fall 2025)	NonCCAP
Week 6: August 5, 2025 - August 11, 2025	Ideal	(NonCCAP) Bulk of Petitions come in around this time through first day of AHC classes	NonCCAP
Week 7: August 12, 2025 - August 18, 2025		Start of Fall Term for HS Partners (Average)	
Week 8: August 19, 2025 - August 25, 2025		Start of Fall Term for AHC	
Week 8: August 19, 2025 - August 25, 2025	Actual	(NonCCAP) We accepted petitions for up until the start of classes (extended)	NonCCAP
Week 8: August 19, 2025 - August 25, 2025		Winter app opens	
Week 9: August 26, 2025 - September 1, 2025	Actual	Influx of Fall Petitions Timeframe	Both
Week 9: August 26, 2025 - September 1, 2025	Actual	(NonCCAP) Late Add influx, Appeal Delays, Registration Processing Delays	NonCCAP
Week 10: September 2, 2025 - September 8, 2025	Actual	CRNs available in DualEnroll & we see beginning of bulk of forms	CCAP
Week 10: September 2, 2025 - September 8, 2025	Ideal	Spring app opens for CCAP students	CCAP
Week 11: September 9, 2025 - September 15, 2025			
Week 12: September 16, 2025 - September 22, 2025			
Week 14: September 30, 2025 - October 6, 2025	Ideal	CCAP CRNs available (Spring 2026)	CCAP
Week 14: September 30, 2025 - October 6, 2025	Ideal	CCAP Registration Begins (Spring 2026)	CCAP
Week 14: September 30, 2025 - October 6, 2025		Spring app opens	
Week 14: September 30, 2025 - October 6, 2025	Actual	Deadline for NonCCAP Petitions (Fall 2025 Term 2)	NonCCAP
Week 15: October 7, 2025 - October 13, 2025			
Week 16: October 14, 2025 - October 20, 2025	Actual	AHC accepting NonCCAP petitions (Winter/Spring 2026)	NonCCAP
Week 16: October 14, 2025 - October 20, 2025		Class Search opens	
Week 17: October 21, 2025 - October 27, 2025			
Week 18: October 28, 2025 - November 3, 2025	Ideal	Fall processing complete for CCAP	CCAP
Week 19: November 4, 2025 - November 10, 2025	Actual	CRN available for CCAP for spring	CCAP
Week 20: November 11, 2025 - November 17, 2025	Actual	NonCCAP Registration Begins (Winter/Spring 2026)	NonCCAP
Week 20: November 11, 2025 - November 17, 2025	Actual	CCAP Registration Begins (Early Spring 2026)	CCAP
Week 21: November 18, 2025 - November 24, 2025			
Week 22: November 25, 2025 - December 1, 2025			
Week 23: December 2, 2025 - December 8, 2025	Ideal	Influx of CN Spring Petitions Timeframe	NonCCAP

FALL

SPRING

APPENDIX D Registration Timeline 2025 - 2026

Week	Actual	Ideal	Notes	CCAP
Week 23: December 2, 2025 - December 8, 2025		Ideal	Deadline for NonCCAP Petitions (Winter 2026)	CCAP
Week 24: December 9, 2025 - December 15, 2025		Ideal	Bulk of CCAP registrations submitted for Spring	CCAP
Week 25: December 16, 2025 - December 22, 2024	Actual	Actual	Processing completed for Fall CCAP	CCAP
Week 25: December 16, 2025 - December 22, 2025		Actual	Start of Winter Term for AHC	
Week 26: December 23, 2025 - December 29, 2025		Actual		
Week 27: December 30, 2025 - January 5, 2026		Actual		
Week 28: January 6, 2026 - January 12, 2026		Actual	Deadline for NonCCAP Petitions (Spring 2026)	
Week 29: January 13, 2026 - January 19, 2026		Actual	Start of Spring Term for HS Partners (Average)	Both
Week 29: January 13, 2026 - January 19, 2026		Actual	Influx of CN petitions	Both
Week 30: January 20, 2026 - January 26, 2026		Actual	Start of Spring Term for AHC	
Week 31: January 27, 2026 - February 2, 2026		Actual		
Week 32: February 3, 2026 - February 9, 2026		Actual	We see bulk of our CCAP forms being turned in	CCAP
Week 33: February 10, 2026 - February 16, 2026		Actual	We see bulk of our CCAP forms being turned in	CCAP
Week 34: February 17, 2026 - February 23, 2026			CCAP Sections Identify and Created - Alicia to meet with High Schools (summer/fall 2026)	
Week 35: February 24, 2026 - March 2, 2026				
Week 36: March 3, 2026 - March 9, 2026				
Week 37: March 10, 2026 - March 16, 2026				
Week 38: March 17, 2026 - March 23, 2026				
Week 39: March 24, 2026 - March 30, 2026			CCAP Sections CRNs Complete (summer/fall 2026)	
Week 40: March 31, 2026 - April 6, 2026				
Week 41: April 7, 2026 - April 13, 2026			AHC accepting NonCCAP petitions (summer/fall 2026)	
Week 41: April 7, 2026 - April 13, 2026	Actual	Actual	Summer/Fall Class Search Opens	
Week 42: April 14, 2026 - April 20, 2026				
Week 42: April 14, 2026 - April 20, 2026			Priority Reg	
Week 43: April 21, 2026 - April 27, 2026		Ideal	Spring processing complete for CCAP	CCAP
Week 44: April 28, 2026 - May 4, 2026				
Week 45: May 5, 2026 - May 11, 2026		Ideal	<i>NonCCAP Registration Begins (Summer/Fall 2026)</i>	
Week 46: May 12, 2026 - May 18, 2026		Actual	Deadline for NonCCAP Petitions (Spring Term 2 2026)	
Week 47: May 19, 2026 - May 25, 2026		Actual	Spring processing complete for CCAP	
Week 48: May 26, 2026 - June 1, 2026				
Week 49: June 2, 2026 - June 8, 2026		Ideal	Influx of Fall Petitions Timeframe	NonCCAP
Week 50: June 9, 2026 - June 15, 2026		Actual	Start of Summer Term for AHC	
Week 51: June 16, 2026 - June 22, 2026				
Week 52: June 23, 2026 - June 29, 2026				

SPRING

FALL

**COLLEGE AND CAREER ACCESS PATHWAYS (CCAP)
PARTNERSHIP AGREEMENT
BETWEEN
THE ALLAN HANCOCK JOINT COMMUNITY COLLEGE DISTRICT
AND
LOMPOC UNIFIED SCHOOL DISTRICT**

This College and Career Access Pathway Partnership Agreement (“CCAP Agreement”) is between the Allan Hancock Joint Community College District (“COLLEGE”) and Lompoc Unified School District (“SCHOOL DISTRICT”). COLLEGE and SCHOOL DISTRICT will collectively be referred to as “PARTIES” or individually as “PARTY”.

RECITALS

WHEREAS, COLLEGE is a community college district whose mission includes providing educational programs and services that are responsive to the needs of the students and communities within the community college services area; and

WHEREAS, SCHOOL DISTRICT is a public school district located within the regional service area of the COLLEGE unless otherwise specified and agreed to as stated in AB 288, Sec. 2, Education Code section 76004, subdivision (e); and

WHEREAS, a high school (“HIGH SCHOOL”) “includes a community school, continuation high school, juvenile court school, or adult education program offering courses for high school diplomas or high school equivalency certificates” as stated in Education Code section 76004, subdivision (a)(2); and

WHEREAS, the PARTIES desire to enter into this CCAP Agreement for the purpose of offering or expanding dual enrollment opportunities, consistent with the provisions of the Education Code, for high school students “who may not already be college bound or who are underrepresented in higher education with the goal of developing seamless pathways from high school to community college for career technical education or preparation for transfer, improving high school graduation rates, and helping high school pupils achieve college and career readiness,” (Ed. Code, § 76004, subdivision (a)); and

WHEREAS, instruction will comply with the student selection standards, curriculum guidelines, recommendations and procedures promulgated by applicable law, the California Community College Chancellor’s Office and the COLLEGE; and

WHEREAS, the PARTIES desire to enter this CCAP, which sets forth their mutual rights and responsibilities and governs their relationship; and

WHEREAS, the PARTIES intend for COLLEGE to report full-time equivalent students (“FTES”) and obtain state apportionment for the subject courses given through this CCAP Agreement in

accordance with California Education Code, section 76004 and the appropriate portions of Title 5 of the California Code of Regulations; and

WHEREAS, participation in the CCAP Agreement is consistent with the core mission of California Community Colleges pursuant to Education Code section 66010.4, and that pupils participating in a CCAP partnership will not lead to enrollment displacement of otherwise eligible adults in the community college (Ed. Code, § 76004, subdivision (k)(2));

NOW, THEREFORE, PARTIES mutually agree as follows:

1. TERM OF AGREEMENT

1.1. Effective Date and Duration. The term of this CCAP Agreement shall be effective on **July 1, 2025**, and continue in effect until **June 30, 2026**, or until duly modified or terminated by the PARTIES in accordance with Section 1.2 of this CCAP Agreement.

1.2. Early Termination.

- a. This agreement may be terminated by either PARTY without cause or for any reason upon giving at least sixty (60) days prior written notice to the other PARTY. Any students currently enrolled in COLLEGE courses under this CCAP Agreement shall be allowed to complete those courses prior to the termination of this CCAP Agreement.
- b. This CCAP Agreement may be terminated by either PARTY with cause if another PARTY fails to comply with the insurance or indemnification requirements or otherwise commits a material breach. Termination will be effective no sooner than 15 calendar days after a written demand to cure is provided and the PARTY fails to cure. This remedy is in addition to any other remedy which may be provided for by law.

1.3. The CCAP Agreement Appendix. This CCAP Agreement outlines the terms of the Agreement.

- a. The CCAP Agreement Appendix shall specify CCAP Agreement Courses as well as additional details regarding, but not be limited to, the total number of high school students to be served and the total number of full-time equivalent students (“FTES”) projected to be claimed by the community college district for those students; the scope, nature, time, location, and listing of community college courses to be offered; and criteria to assess the ability of pupils to benefit from those courses:

Appendix A: Agreement with Instructor.

Appendix B: Identification of CCAP Pathways for Course-Specific College and Career Pathway Opportunities.

Appendix C: CCAP Agreement Courses Approved for 2025-2026.

Appendix D: Registration Timeline

- b. The CCAP Agreement Appendix C shall be reviewed and approved annually by both PARTIES by a duly adopted written amendment to this Agreement.

1.4. **Points of contact and Educational Administrators** are as follows:

COLLEGE:	Thomas Lamica, dean, academic affairs
SCHOOL DISTRICT:	Brian Jaramillo, assistant superintendent, educational services
HIGH SCHOOL SITES:	Celeste Pico, principal, Lompoc High School
	Laurel Schroeder, principal, Maple High School
	Brian Grimnes, Cabrillo High School

(Ed. Code, § 76004, subdivision (c)(2))

- 1.5. A copy of the COLLEGE and SCHOOL DISTRICT CCAP Agreement shall be filed with the office of the Chancellor of the California Community Colleges and with the California Department of Education before the start of the CCAP partnership. (Ed. Code, § 76004, subdivision (c)(3).)
- 1.6. COLLEGE and SCHOOL DISTRICT shall present this CCAP agreement at an open public meeting of their respective governing boards, allowing for public comments prior to consideration for approval or disapproval of this CCAP agreement. (Ed. Code, § 76004, subdivision (b)(2).)

2. DEFINITIONS

- 2.1. **CCAP Agreement Courses.** CCAP Agreement Courses offered as part of this CCAP Agreement shall be community college courses acceptable towards a career technical education credential or certificate, preparation for transfer, or appropriate to improve high school graduation rates or help high school pupils achieve college and career readiness. (Ed. Code § 76004, subdivision (a).) All community college courses offered at the SCHOOL DISTRICT have been approved in accordance with the policies and guidelines of COLLEGE and applicable law. Courses offered at the COLLEGE that are open to the public for enrollment fall outside of this CCAP agreement and are subject to all conditions and rules of the COLLEGE.
- 2.2. **Pupil or Student Fees.** Pupil or Student is defined as a resident or nonresident student attending HIGH SCHOOL in California. SCHOOL DISTRICT pupils enrolled in a course offered through this CCAP Agreement shall not be assessed any fee that is prohibited by Education Code section 49011 (Ed. Code § 76004, subdivision (f)), including a fee charged to a student or a student's parent or guardian as a condition for course registration or for textbooks, supplies, materials and equipment needed to participate in the course. Students who are enrolled in a combination of CCAP and regular credit college courses will be subject to all fees assessed for the regular credit college enrollment for the regular credit college courses.

3. STUDENT ELIGIBILITY, SELECTION AND ENROLLMENT, ADMISSION, REGISTRATION, MINIMUM SCHOOL DAY

- 3.1. **Student Eligibility.** Students who "may not already be college bound or who are underrepresented in higher education, with the goal of developing seamless pathways from high school to community college for career technical education or preparation for transfer, improving high school graduation rates, or helping high school pupils to achieve college and career readiness" and "underachieving students, those from groups underrepresented in postsecondary education, those who are seeking advanced studies while in high school, and those seeking a career technical education credential or certificate" are eligible to participate in CCAP courses hosted at a SCHOOL DISTRICT site. (Education Code § 76004, subdivision (a); Assembly Bill 288 (2015) Section I, subdivision (d))
- 3.2. **Student Selection and Enrollment.** Enrollment shall be open to all eligible students as part of the CCAP Agreement who have been admitted to the COLLEGE and who meet all applicable prerequisites. Student selection criteria will be further specified in the CCAP Agreement Appendix C. Applicable prerequisite courses, training, or experience and standards required as preparation for courses offered through the CCAP Agreement will be determined by COLLEGE and shall be in compliance with applicable law and COLLEGE standards and policies.
- 3.3. **College Admission and Registration.** Procedures for students participating in the CCAP Agreement shall be governed by the COLLEGE and shall be in compliance with the admissions and registration guidelines outlined in applicable law and COLLEGE policy.
- 3.4. **Records of Student Attendance.** All records of student attendance and achievement shall be submitted to COLLEGE periodically using the COLLEGE student information system or upon demand and shall be maintained by COLLEGE.
- 3.5. **Priority Enrollment.** Students enrolling in a CCAP course will have priority enrollment by virtue of their status. High school students enrolling in non-CCAP college courses will not be eligible for priority registration.
- 3.6. **Physical Education Courses.** As part of a CCAP Agreement, a participating community college district shall not provide physical education course opportunities to high school students or any other course opportunities that do not assist in the attainment of the goals associated with career technical education or preparation for transfer, improving high school graduation rates, or helping high school students achieve career and college readiness. (Ed. Code § 76004, subdivision (d)).
- 3.7. **Maximum Units.** Students participating under a CCAP Agreement may enroll in up to a maximum of 15 units per term, without exception, if all the following conditions specified in Assembly Bill 288, Sec. 2 (p)(1)(2)(3) are satisfied:
- a. The units constitute no more than four community college courses per term.
 - b. The units are part of an academic program that is part of a CCAP partnership agreement established pursuant to this article.
 - c. The units are part of an academic program that is designed to award students both a high school diploma and an associate degree or a certificate or credential.
- 3.8. **Minimum School Day.** The SCHOOL DISTRICT shall certify that it shall teach SCHOOL DISTRICT students participating as part of a CCAP Agreement no less than the number of instructional minutes required to complete a minimum school day pursuant to Education

Code sections 46141 and 46142.

- 3.9. **Enrollment Restriction.** COLLEGE reserves the right to block students from enrolling in any courses for students who incur an unpaid debt for a non-CCAP class at the college. COLLEGE agrees to remove the enrollment block when debt is paid in full.

4. COLLEGE APPLICATION PROCEDURE

- 4.1. The COLLEGE will be responsible for processing student applications.
- 4.2. The COLLEGE will provide the necessary admission and registration forms and procedures, and both COLLEGE and SCHOOL DISTRICT will jointly ensure that each applicant accepted has met all the enrollment requirements.
- 4.3. The SCHOOL DISTRICT agrees to assist COLLEGE in the admission and registration of SCHOOL DISTRICT students as may be necessary and requested by COLLEGE.

5. PARTICIPATING STUDENTS

- 5.1. The total cost of books and instructional materials for SCHOOL DISTRICT students who enroll in a COLLEGE course offered as part of this CCAP Agreement will be borne by SCHOOL DISTRICT.
- 5.2. Both COLLEGE and SCHOOL DISTRICT will ensure that ancillary and support services are accessible to students (e.g., Tutoring.)
- 5.3. A student taking courses under this CCAP Agreement with an Individual Education Plan or 504 Plan with the SCHOOL DISTRICT may request accommodation for his or her disability to participate in the educational programs and activities required by the COURSE and COLLEGE. Accommodation required by state law or SCHOOL DISTRICT policy will be provided through SCHOOL DISTRICT in consultation with the COLLEGE Learning Assistance Program (LAP) Office. Students requesting services by the LAP office will need to follow the standard process for requesting accommodations.

6. CCAP AGREEMENT COURSES

- 6.1. The COLLEGE may limit enrollment in a community college course solely to eligible high school students if the course is offered at a high school campus during the regular school day and the community college course is offered pursuant to this CCAP Agreement.
- 6.2. The COLLEGE is responsible for all courses and educational programs offered as part of CCAP Agreement .
- 6.3. The scope, nature, time, location, and listing of courses offered by a COLLEGE shall be determined by COLLEGE in consultation with the SCHOOL DISTRICT and with the approval of the COLLEGE and will be recorded in the Appendix C to this CCAP Agreement.
- 6.4. Courses offered as part of a CCAP Agreement shall be jointly selected and approved by COLLEGE and SCHOOL DISTRICT.
- 6.5. Courses offered as part of this CCAP Agreement shall have a minimum enrollment of fifteen (15) students.
- 6.6. The SCHOOL DISTRICT confirms that each approved CCAP course is held for no less than

50 minutes each class day in full compliance with the course outcomes determined by the COLLEGE.

- 6.7. Degree and certificate programs that are included in the CCAP agreement must have been approved by the California Community College Chancellor's Office and courses offered at the SCHOOL DISTRICT shall adhere to the official course outline of record and the student learning outcomes established by the associated academic department within the COLLEGE, approved by the COLLEGE Academic Policy & Planning (AP&P) Committee and submitted to the Chancellor's Office. Course outlines will be provided to the SCHOOL DISTRICT.
- 6.8. Courses must meet the number of hours sufficient to meet the stated performance objectives as outlined in the course outlines provided to the SCHOOL DISTRICT on a semester basis.
- 6.9. Courses offered at the SCHOOL DISTRICT as part of this CCAP Agreement shall be of the same quality and rigor as those offered on the COLLEGE campus and shall be in compliance with COLLEGE academic standards.
- 6.10. Courses offered as part of this CCAP Agreement will comply with all applicable regulations, policies, procedures, prerequisites, and standards applicable to the COLLEGE as well as any corresponding policies, practices, and requirements of the SCHOOL DISTRICT. In the event of a conflict between the COLLEGE course related regulations, policies, procedures, prerequisites and standards and SCHOOL DISTRICT policies, practices and requirements, the COLLEGE regulations, policies, procedures, prerequisites, and standards, shall prevail.
- 6.11. A student's withdrawal prior to completion of a course offered as part of this CCAP Agreement shall be in accordance with COLLEGE guidelines, policies, pertinent statutes and regulations.
- 6.12. Supervision and evaluation of students enrolled in courses offered as part of this CCAP Agreement shall be in accordance with COLLEGE guidelines, policies, pertinent statutes and regulations.
- 6.13. COLLEGE has the sole right to control and direct the instructional activities for all CCAP Agreement courses and all instructors, including those who are SCHOOL DISTRICT employees.
- 6.14. This CCAP Agreement certifies that any remedial course taught by community college faculty at a partnering high school campus shall be offered only to high school students who do not meet their grade level standard in math, English, or both on an interim assessment in grade 10 or 11, as determined by the partnering SCHOOL DISTRICT, and shall involve collaborative effort between the SCHOOL DISTRICT and the COLLEGE faculty to deliver an innovative remediation course as an intervention in the student's junior or senior year to ensure the student is prepared for college-level work upon graduation.
- 6.15. CCAP Agreement Courses outlined in Appendix C shall be updated annually and approved before the start of each academic year.

7. INSTRUCTORS

- 7.1. All instructors teaching COLLEGE courses offered as part of this CCAP Agreement must meet the minimum qualifications for instruction in a California community college as set

- forth in Title 5 California Code of Regulations, Sections 53410 and 58060 or as amended.
- 7.2. The CCAP Agreement Appendix C shall specify which participating SCHOOL DISTRICT or COLLEGE will be the employer of record for purposes of assignment monitoring and reporting to the county office of education.
 - 7.3. This CCAP Agreement specifies that the SCHOOL DISTRICT will assume reporting responsibilities pursuant to applicable federal teacher quality mandates.
 - 7.4. Instructors who teach COLLEGE courses offered as part of this CCAP Agreement must provide the supervision and control reasonably necessary for the protection of the health and safety of students and may not have any other assigned duty during the instructional activity.
 - 7.5. Instructors who teach COLLEGE courses shall comply with the fingerprinting requirements set forth in Education Code section 45125 or as amended and the tuberculosis testing and risk assessment requirements of California Health and Safety Code section 121525 or as amended. In addition to any other prohibition or provision, no person who has been convicted of a violent or serious felony shall be eligible to teach any courses offered as part of this CCAP Agreement or otherwise provide services on a SCHOOL DISTRICT site. SCHOOL DISTRICT shall immediately notify COLLEGE if an instructor is charged with an offense prohibited by Education Code sections 44010 or 44011.
 - 7.6. Prior to teaching, faculty provided by the SCHOOL DISTRICT shall participate in required discipline-specific training and orientation from COLLEGE regarding, but not limited to, course curriculum, assessment criteria, pedagogy, course philosophy, testing and grading procedures record keeping, and other instructional responsibilities. Such training shall be approved and provided by the COLLEGE.
 - 7.7. Prior to teaching, instructors provided by the COLLEGE may receive training and orientation from SCHOOL DISTRICT regarding, but not limited to, SCHOOL DISTRICT policies, practices, and requirements. Such training may be approved and provided by the SCHOOL DISTRICT.
 - 7.8. Faculty provided by the SCHOOL DISTRICT are eligible to participate in professional development activities sponsored by the COLLEGE as required by the terms and condition of the contract and shall be encouraged to participate in ongoing collegial interaction to include, but not limited to, addressing course content, course delivery, assessment, evaluation, and/or research and development in the field.
 - 7.9. The COLLEGE shall evaluate faculty performance for the college courses using the adopted evaluation of process and standards for faculty of the COLLEGE, subject to the approval of COLLEGE.
 - 7.10. The COLLEGE and SCHOOL DISTRICT will work collaboratively to identify instructors from SCHOOL DISTRICT who may meet minimum qualification requirements or local equivalency standards to teach a COLLEGE course and encourage them to apply for consideration. Instructors will be required to go through the COLLEGE screening process for possible selection and assignment to the course.
 - 7.11. The SCHOOL DISTRICT teachers approved to teach COLLEGE courses remain employees of the SCHOOL DISTRICT, subject to the authority of the SCHOOL DISTRICT, but will also be subject to the authority of COLLEGE specifically with regard to their duties as COLLEGE instructors, pursuant to the terms of Appendix A.
 - 7.12. The COLLEGE shall determine the number of instructors, the ratio of instructors to

students, and the subject areas of instruction.

- 7.13. Faculty provided by the SCHOOL DISTRICT who do not comply with the policies, regulations, standards, and expectations of the COLLEGE shall be ineligible to teach college courses under this CCAP Agreement.
- 7.14. SCHOOL DISTRICT teachers approved to teach CCAP Courses under this CCAP Agreement must submit grades to both the COLLEGE and SCHOOL DISTRICT using the COLLEGE student information system by the established timeline (Appendix D).
- 7.15. SCHOOL DISTRICT teachers approved by the COLLEGE shall sign an Agreement with the Instructor (Appendix A) prior to the start of each academic year.
- 7.16. SCHOOL DISTRICT teachers approved by the COLLEGE shall provide support to high school students taking COLLEGE courses under CCAP agreement with COLLEGE admission and registration procedures.

8. ASSESSMENT OF LEARNING AND CONDUCT

- 8.1. Students enrolled in COLLEGE courses offered as part of this CCAP Agreement at the SCHOOL DISTRICT shall be held to the same standards of achievement as students in courses taught on the COLLEGE campus.
- 8.2. Students enrolled in COLLEGE courses offered as part of this CCAP Agreement at the SCHOOL DISTRICT shall be held to the same grading standards as those expected of students in courses taught on the COLLEGE campus.
- 8.3. Students enrolled in COLLEGE courses offered as part of this CCAP Agreement at the SCHOOL DISTRICT shall be assessed using the same methods (e.g., papers, portfolios, quizzes, labs, etc.) as students in courses taught on the COLLEGE campus.
- 8.4. Students enrolled in COLLEGE courses offered as part of this CCAP Agreement at the SCHOOL DISTRICT shall be held to the same behavioral standards as those expected of students in courses taught on the COLLEGE campus.

9. LIAISON AND COORDINATION OF RESPONSIBILITIES

- 9.1. The COLLEGE shall appoint an educational administrator who will serve as point of contact to facilitate coordination and cooperation between COLLEGE, SCHOOL DISTRICT, and HIGH SCHOOL in conformity with COLLEGE policies and standards. (Ed. Code, § 76004, subd. (c)(2).) Among other things, the COMMUNITY COLLEGE DISTRICT Educational Administrator and the SCHOOL DISTRICT Educational Administrator described in Section 9.2, shall collaborate to determine the process for timely receiving, investigating, and remediating complaints of sexual misconduct or other conduct covered by Title IX of the Education Amendments of 1972 alleged to have occurred in or related to the CCAP program.
- 9.2. The SCHOOL DISTRICT shall appoint an educational administrator who will serve as point of contact to facilitate coordination and cooperation between SCHOOL DISTRICT, COLLEGE, HIGH SCHOOL in conformity with SCHOOL DISTRICT policies and standards.
- 9.3. This CCAP Agreement requires an annual report to the office of the Chancellor of the California Community Colleges by COLLEGE and SCHOOL DISTRICT. COLLEGE shall complete and file the Apportionment Attendance Report (CCFS-320); SCHOOL

DISTRICT agrees to provide the following information, when requested by COLLEGE, in accordance with AB 288 Section 2, Education Code Section 76004:

- a. The total number of high school students by school site enrolled in each partnership, aggregated by gender and ethnicity, and reported in compliance with all applicable state and federal privacy laws.
- b. The total number of community college courses by course category and type and by school site enrolled in by CCAP partnership participants.
- c. The total number and percentage of successful course completions, by course category and type and by school site, of CCAP partnership participants.
- d. The total number of full-time equivalent students generated by CCAP partnership community college district participants.

10. DISPUTES

10.1. COLLEGE and SCHOOL DISTRICT recognize that, from time to time, disputes may arise between COLLEGE employees or students and SCHOOL DISTRICT employees or students. When such disputes arise, COLLEGE and SCHOOL DISTRICT shall collaborate and use their best efforts to resolve them informally. Where informal resolution is not successful or the PARTIES must address a formal inter-agency complaint, the following process will be utilized to resolve the matter.

- a. The PARTY receiving the complaint will timely notify the other, and promptly provide the other PARTY with any written complaint received.
- b. The Educational Administrators will review the complaint to determine, based on the nature of the complaint, whether any statutory or regulatory timelines or other procedural requirements apply, including but not limited to:

10.1.b.1. Whether COLLEGE is required to investigate the complaint to the State Chancellor pursuant to Title 5 of the California Code of Regulations.

10.1.b.2. Whether, based on the nature of the complaint, the complainant is entitled to any rights or protections with regard to how the complaint is handled, pursuant to Title 5 or applicable state or federal laws, including but not limited to Title IX of the Education Amendments of 1972.

10.1.b.3. If either Educational Administrator finds such rights to exist, he or she shall notify the other Educational Administrator, and COLLEGE and SCHOOL DISTRICT shall cooperate as needed in carrying out these requirements. It is understood that such requirements may include but are not limited to conducting a formal investigation within regulatory timelines or the implementation of interim safety measures for the complainant.

- c. Within a reasonable time, either PARTY receiving the complaint, the PARTIES will discuss the nature and severity of the allegations and come to a mutual agreement regarding the need for and scope of any investigation required. If it is agreed that a formal investigation is required, the PARTIES will mutually agree upon an investigator, who may be an outside investigator, or qualified employee of COLLEGE or SCHOOL DISTRICT. If the PARTIES agree to have the matter investigated internally by either a COLLEGE or SCHOOL DISTRICT employee, the other PARTY may designate an

- employee to attend all witness interviews. Where it is determined that an outside investigator will be used, the cost will be divided between the PARTIES.
- d. If, despite the good faith effort of the PARTIES, they are unable to agree on a process for investigating the complaint, the PARTY whose employee/student is the subject of the complaint will determine the process.
 - e. The COLLEGE and SCHOOL DISTRICT will cooperate in any investigation initiated and make its employees available to the investigator.
 - f. Interviews of COLLEGE and SCHOOL DISTRICT employees shall comply with any rights and protections afforded to them under an applicable collective bargaining agreement or state or federal law, including but not limited to the right to have a representative present during an interview that could lead to discipline.
 - g. The investigator will prepare a report that will be provided to both PARTIES setting forth findings as to the allegations and the basis for the findings.
 - h. The COLLEGE and SCHOOL DISTRICT shall share any and all materials from the investigation, unless sharing would cause a PARTY to violate confidentiality or privacy laws.
 - i. The COLLEGE and SCHOOL DISTRICT have sole discretion in determining any disciplinary measures to be imposed against their respective employees or students.
 - j. Regardless of any disciplinary measures taken by the COLLEGE or SCHOOL DISTRICT against its respective employees or students, the other PARTY retains the right to have the subject of a sustained complaint removed from participating in or providing services for the program that is the subject of this CCAP Agreement.

11. APPORTIONMENT

- 11.1. COLLEGE shall include the students enrolled in a CCAP Agreement course in its report of full-time equivalent students (FTES) for purposes of receiving state apportionments when the course(s) complies with current requirements for dual enrollment under applicable California law.
- 11.2. For purposes of allowances and apportionments from Section B of the State School Fund, a community college district conducting a closed course on a high school campus shall be credited with those units of full-time equivalent students attributable to the attendance of eligible high school pupils.
- 11.3. The COLLEGE shall not receive a state allowance or apportionment for an instructional activity for which the SCHOOL DISTRICT has been, or shall be, paid an allowance or apportionment. (Ed. Code § 76004, subdivision (o)(2)).
- 11.4. The attendance of a SCHOOL DISTRICT pupil at the COLLEGE as a special part-time or full-time student pursuant to this section is authorized attendance for which the COLLEGE shall be credited or reimbursed pursuant to Section 48802 or 76002, provided that no school district has received reimbursement for the same instructional activity.

12. CERTIFICATIONS

- 12.1. The SCHOOL DISTRICT certifies that:

- a. The direct education costs of the courses offered as part of this CCAP Agreement are not fully funded through other sources.
- b. It agrees and acknowledges that the COLLEGE will claim apportionment for the SCHOOL DISTRICT students enrolled in community college course(s) under this CCAP Agreement.
- c. Any COLLEGE instructor teaching a course at the SCHOOL DISTRICT has not displaced or resulted in the termination of an existing high school teacher teaching the same course on that high school campus.

12.2. The COLLEGE certifies that:

- a. A community college course offered for college credit at the participating SCHOOL DISTRICT does not reduce access to the same course offered at the partnering COLLEGE.
- b. The COLLEGE has not received full compensation for the direct education costs for the conduct of the courses offered as part of this CCAP Agreement from other sources.
- c. The Agreement is consistent with the core mission of the COLLEGE pursuant to Section 66010.4 and students participating in this CCAP Agreement will not lead to displacement of otherwise eligible adults at the COLLEGE.
- d. A qualified SCHOOL DISTRICT instructor teaching a course offered for college credit at a high school campus has not displaced or resulted in the termination of an existing COLLEGE faculty member teaching the same course at the partnering community college campus.

12.3. The PARTIES certify that:

- a. Any COLLEGE instructor teaching a course on a SCHOOL DISTRICT campus has not been convicted of any sex offense as defined in Education Code section 44010 or as amended, or any controlled substance offense as defined in Education Code section 44011 or as amended.
- b. The SCHOOL DISTRICT and COLLEGE comply with local collective bargaining agreements and all state and federal reporting requirements regarding the qualifications of the teacher or faculty member teaching a CCAP Agreement course offered for high school credit. (AB288 Sec. 2 (I).)

13. PROGRAM IMPROVEMENT

- 13.1. The COLLEGE and the SCHOOL DISTRICT may annually conduct surveys of participating SCHOOL DISTRICT pupils, instructors, principals, and school counselors for the purpose of informing practice, adjusting, and improving the quality of courses offered as part of this CCAP Agreement.

14. RECORDS

- 14.1. Permanent records of student attendance, grades and achievement will be maintained by both the SCHOOL DISTRICT and COLLEGE for SCHOOL DISTRICT students who

enroll in course(s) offered as part of this CCAP Agreement. Permanent records of student enrollment, grades, and achievement for COLLEGE students shall be maintained by COLLEGE.

- 14.2. Each PARTY shall maintain records pertaining to this CCAP Agreement as may be required by federal and state law. Each PARTY may review and obtain a copy of the other PARTY'S pertinent records subject to federal and state privacy statutes.
- 14.3. SCHOOL DISTRICT instructors will submit grades to the COLLEGE when due according to the COLLEGE schedule per section 7.14. The SCHOOL DISTRICT will include all criteria identified by the COLLEGE for grading purposes.
- 14.4. COLLEGE may provide the SCHOOL DISTRICT with a report on participating students' final grades after each term.

15. CCAP AGREEMENT DATA MATCH AND REPORTING

- 15.1. COLLEGE and SCHOOL DISTRICT shall ensure operational protocols consistent with the collection of participating student data and the timely submission of the data.
- 15.2. COLLEGE shall report all program and participating student data to the office of the Chancellor of the California Community Colleges.

16. DATA SHARING

- 16.1. COLLEGE and SCHOOL DISTRICT may share confidential student data for the purposes of evaluating the educational services provided under this CCAP agreement and for evaluating student performance pursuant to participating in CCAP courses. Any data shared will be for research and analytical purposes aimed at understanding student performance and improving applicable federal and state laws concerning access to and confidentiality of student record information as described in Section 17 of this agreement.

17. PRIVACY OF STUDENT RECORDS

- 17.1. COLLEGE and SCHOOL DISTRICT understand and agree that education records of students enrolled in a CCAP course and personally identifiable information contained in those educational records are subject to the Family Educational Rights and Privacy Act (FERPA) 20 U.S.C. § 1232g; 34 C.F.R. Part 99, including the disclosure provisions of § 99.30 and state law as outlined in Education Code section 49064 and section 49076). COLLEGE and SCHOOL DISTRICT agree to hold all student education records generated pursuant to this CCAP Agreement in strict confidence and further agree not to disclose such records except as authorized by applicable law or regulation for COLLEGE records or by the parent or guardian's prior written consent for HIGH SCHOOL records. (34 C.F.R. § 99.33 (a), (b); 34 C.F.R. § 99.34(b) and Education Code §§ 49064 and 49076.)
- 17.2. **Limitation on Use.** COLLEGE and SCHOOL DISTRICT shall use each student education record that they may receive pursuant to this CCAP Agreement solely for purposes consistent with their authority to access that information pursuant to Federal and State law, as may be as applicable. (34 C.F.R. § 99.31, 34 C.F.R. § 99.34, and Education Code § 49076.)
- 17.3. **Recordkeeping Requirements.** COLLEGE and SCHOOL DISTRICT shall comply with the requirements governing maintenance of records of each request for access to and

each disclosure of student education records set forth under Title 34, Code of Federal Regulations § 99.32 and under Education Code § 49064 as applicable.

- 17.4. **Acknowledgement of Receipt of Notice of FERPA Regulations.** By signature of its authorized representative or agent on this Agreement, COLLEGE and SCHOOL DISTRICT hereby acknowledges that it has been provided with the notice required under 34 C.F.R. § 99.33(d) that it is strictly prohibited from re-disclosing student education records to any other person or entity except as authorized by applicable law or regulation. Parent or guardian requests for information will need to be addressed directly by the HIGH SCHOOL or SCHOOL DISTRICT personnel.

18. REIMBURSEMENT

- 18.1. The SCHOOL DISTRICT shall invoice the COLLEGE no later than 30 (thirty) days after the start of each term for the instructional services provided through this CCAP agreement as follows:
- a. For courses taught by COLLEGE-approved SCHOOL DISTRICT teachers and COLLEGE instructors on HIGH SCHOOL campuses during regular high school hours rendered at the rate of \$1,000.00 per course unit delivered to CCAP students.

Example: 3 CCAP courses @ 3 units each = 9 units x \$1,000.00 = \$9,000.00

- 18.2. The SCHOOL DISTRICT confirms that each approved CCAP course is held for a minimum of 50 minutes each class day. SCHOOL DISTRICT instructors confirm course delivery of 50 minutes on each class day. Any gap between 50 minutes and the actual class time of 2 minutes or less will be reimbursed by the COLLEGE at a rate of \$1.00 per minute for a CCAP course taught by SCHOOL DISTRICT instructors. An additional 25% will be paid to cover ancillary payroll requirements.

Example: \$1.00 per minute x 2 minutes x 712 class days (per LUSD academic calendar) = \$1,424 + \$356 (25%) = \$1,780.

- 18.3. The COLLEGE shall make payment to the SCHOOL DISTRICT within 30 days of receiving the invoice for instructional services rendered.
- 18.4. The COLLEGE is required to report to the state the percentage of funds paid to an agency to the SCHOOL DISTRICT that will provide direct instruction on behalf of the college as part of the CCAP partnership agreement. The SCHOOL DISTRICT will use 100% of all funds received from Allan Hancock College in fulfillment of this agreement to pay for direct instructional costs. (Ed. Code § 84632).

19. FACILITIES

- 19.1. The SCHOOL DISTRICT will provide adequate classroom space at its facilities or other mutually agreed upon locations to conduct the instruction and do so without charge to COLLEGE or students. SCHOOL DISTRICT agrees to clean, maintain, and safeguard SCHOOL DISTRICT's premises. SCHOOL DISTRICT warrants that its facilities are safe and compliant with all applicable buildings, fire, and safety codes.

- 19.2. The SCHOOL DISTRICT will furnish, at its own expense, all course materials, specialized equipment, books and other necessary equipment for all SCHOOL DISTRICT students. The parties understand that such equipment and materials are the SCHOOL DISTRICT's sole property.
- 19.3. The SCHOOL DISTRICT facilities may be used by COLLEGE for COLLEGE course offerings before or after regular high school schedule at no additional cost. Prior approval by the SCHOOL DISTRICT is required. COLLEGE courses offered before or after the regular high school schedule will be open to the public.

20. INDEMNIFICATION

20.1. The SCHOOL DISTRICT agrees to and shall indemnify, save and hold harmless the COLLEGE, and its governing board, officers, employees, administrators, independent contractors, subcontractors, agents and other representatives from any and all claims, demands, liabilities, costs, expenses, damages, causes of action, losses, and judgments, arising out of SCHOOL DISTRICT's performance of this CCAP Agreement. The obligation to indemnify shall extend to all claims and losses that arise out of SCHOOL DISTRICT's or its trustees', officers', agents', or employees' negligence, wrongful acts or omissions, or willful misconduct related to this CCAP Agreement or performance of this CCAP Agreement. The provisions of this section shall survive the termination or expiration of this CCAP Agreement.

20.2. The COLLEGE agrees to and shall indemnify, save and hold harmless the SCHOOL DISTRICT and its governing board, officers, employees, administrators, independent contractors, subcontractors, agents and other representatives from any and all claims, demands, liabilities, costs, expenses, damages, causes of action, losses, and judgments, arising out of COLLEGE'S performance of this CCAP Agreement. The obligation to indemnify shall extend to all claims and losses that arise out of COLLEGE'S or its trustees', officers', agents', or employees' negligence, wrongful acts or omissions, or willful misconduct related to this CCAP Agreement or performance of this CCAP Agreement. The provisions of this section shall survive the termination or expiration of this CCAP Agreement.

21. INSURANCE

21.1. The SCHOOL DISTRICT, in order to protect the COLLEGE, its agents, employees and officers against claims and liability for death, injury, loss and damage arising out of or in any manner connected with the performance and operation of the terms of this CCAP Agreement, shall secure and maintain in force during the entire term of this CCAP Agreement, insurance coverage or an approved program of self-insurance in the amount of not less than ONE MILLION DOLLARS (\$1,000,000) per incident and TWO MILLION DOLLARS (\$2,000,000) general aggregate for personal injury, bodily injury, death, and property and other damage, with an admitted California insurer duly licensed to engage in the business of insurance in the State of California, or public entity risk management Joint Powers Authority, authorized to provide public liability and property damage insurance in the state of California. Said policy of insurance, insurance coverage through a public entity risk management JPA, or program of self-insurance shall expressly name the COLLEGE, its

agents, employees and officers as an additional insured for the purposes of this CCAP Agreement. A certificate of insurance including such endorsement shall be furnished to the COLLEGE.

- 21.2. The COLLEGE, in order to protect the SCHOOL DISTRICT, its agents, employees and officers against claims and liability for death, injury, loss and damage arising out of or in any manner connected with the performance and operation of the terms of this CCAP Agreement, shall secure and maintain in force during the entire term of this CCAP Agreement, insurance coverage or an approved program of self- insurance in the amount of not less than ONE MILLION DOLLARS (\$1,000,000) per incident and TWO MILLION DOLLARS (\$2,000,000) general aggregate for personal injury, bodily injury, death, and property and other damage, with an admitted California insurer duly licensed to engage in the business of insurance in the State of California, or public entity risk management Joint Powers Authority, authorized to provide public liability and property damage insurance in the State of California. Said policy of insurance, insurance coverage through a public entity risk management JPA or program of self-insurance shall expressly name the SCHOOL DISTRICT, its agents, employees and officers as an additional insured for the purposes of this CCAP Agreement. A certificate of insurance including such endorsement shall be furnished to the SCHOOL DISTRICT.
- 21.3. For the purpose of Workers' Compensation, SCHOOL DISTRICT shall be the "primary employer" for all its employees who perform services as instructors and support staff. SCHOOL DISTRICT shall be solely responsible for processing, investigating, defending, and paying all workers' compensation claims by their respective SCHOOL DISTRICT employees made in connection with performing services and receiving instruction under this CCAP Agreement. SCHOOL DISTRICT agrees to hold harmless, indemnify, and defend COLLEGE, its directors, officers, agents, and employees from any liability resulting from its failure to process, investigate, defend, or pay any workers' compensation claims by SCHOOL DISTRICT employees connected with providing services under this CCAP Agreement.

22. NON-DISCRIMINATION

- 22.1. Neither the SCHOOL DISTRICT nor the COLLEGE shall discriminate on the basis of race or ethnicity, gender, nationality, physical or mental disability, sexual orientation, religion, or any other protected class under California State or federal law.

23. NOTICES

- 23.1. Any and all notices required to be given hereunder shall be deemed given when personally delivered or deposited in the U.S. Mail, postage to be prepaid, to the following addresses:

Allan Hancock College Joint Community College District
 800 S. College Drive
 Santa Maria, CA 93460
 Attn: Dennis Curran

LOMPOC UNIFIED SCHOOL DISTRICT
1301 North A Street, Lompoc, CA 93436
Attn: Dr. Clara A. Finneran

24. MODIFICATION AND AMENDMENT

- 24.1. Appendix A through D to this CCAP Agreement is incorporated by this reference into this CCAP Agreement.
- 24.2. This CCAP Agreement and Appendix A through D to this CCAP Agreement set forth the entire agreement between the PARTIES relating to the subject matter of this CCAP Agreement. This CCAP Agreement and Appendix A through D to this CCAP Agreement supersede any prior agreements, promises, negotiations, or representations, express or implied, oral or written, not included in this CCAP Agreement and Appendix A through D to this CCAP Agreement.
- 24.3. This Agreement may be amended only with the mutual consent of the Parties. All amendments must be in writing and must be approved by the Parties' respective governing Boards.

25. GOVERNING LAWS

- 25.1. This CCAP Agreement will be governed by and construed in accordance with California law, and the venue of any action or proceeding in connection with this CCAP Agreement shall be Santa Barbara County, California.

26. COMMUNITY COLLEGE DISTRICT BOUNDARIES

- 26.1. For locations outside the geographical boundaries of Allan Hancock College Joint Community College District, the COLLEGE will comply with the requirements of Title 5 of the California Code of Regulations, Sections 55300 et seq. or as amended, concerning approval by adjoining high school or community college districts and use of non-district facilities.

27. SEVERABILITY

- 27.1. This CCAP Agreement shall be considered severable, such that if any provision or part of the CCAP Agreement is ever held invalid under any law or ruling, that provision or part of the CCAP Agreement shall remain in force and effect to the extent allowed by law, and all other provisions or parts shall remain in full force and effect.

28. COUNTERPARTS

- 28.1. This CCAP Agreement may be executed by the PARTIES in separate counterparts, each of which when so executed and delivered shall be an original, but all such counterparts shall together constitute one and the same instrument.

IN WITNESS WHEREOF, the PARTIES hereto have caused this CCAP Agreement to be executed

on the dates set forth below, to be effective as of the Effective Date.

ALLAN HANCOCK JOINT COMMUNITY
COLLEGE DISTRICT

LOMPOC UNIFIED SCHOOL DISTRICT

By: _____
Associate Superintendent/Vice President of
Finance and Administration

By: _____
Superintendent

Date: _____

Date: _____

ALLAN HANCOCK JOINT COMMUNITY
COLLEGE DISTRICT BOARD MEETINGS

LOMPOC UNIFIED SCHOOL DISTRICT
BOARD MEETINGS

Information Board Meeting Date:

Information Board Meeting Date:

Public Comment
and Approval Board Meeting Date:

Public Comment
and Approval Board Meeting Date:

APPENDIX A

ALLAN HANCOCK COLLEGE JOINT COMMUNITY COLLEGE DISTRICT

Agreement with INSTRUCTOR

This agreement is made and entered into this _____ [day] of _____ [month] ____ [year] by three parties: The Allan Hancock College Joint Community College District (hereinafter “COLLEGE”), the _____ [high school district] (hereinafter “SCHOOL DISTRICT”) and _____ [first name, last name], an employee of the SCHOOL DISTRICT (hereinafter “INSTRUCTOR”) who is being assigned to the COLLEGE on a part-time basis pursuant to Title 5, California Code of Regulations, section 58058(b).

WHEREAS, the SCHOOL DISTRICT has the experience, training, equipment and other resources, and staff necessary to provide instruction to COLLEGE students through the CCAP Agreement;

WHEREAS, Title 5, California Code of Regulations, section 58050, subdivision (a) provides authority for claiming apportionment;

NOW, THEREFORE, the three parties to this Agreement hereby agree as follows:

1. The SCHOOL DISTRICT’s INSTRUCTOR is an employee of the SCHOOL DISTRICT who shall meet “Minimum Qualifications” for the academic position of COLLEGE’s INSTRUCTOR as established by the COLLEGE and as determined by the COLLEGE.
2. The SCHOOL DISTRICT’s INSTRUCTOR is professionally and specially trained and competent to provide the supervisory and/or instructional services required by the COLLEGE.
3. The INSTRUCTOR will be an employee of the COLLEGE for purposes of the Attendance Accounting Standards (Ed. Code, § 58050). COLLEGE has the right to; 1) evaluate and terminate INSTRUCTOR; 2) evaluate the quality of instruction to ensure that it meets the needs of students; 3) evaluate the quality and rigor equal to the COLLEGE’S approved course outline of record and the accreditation requirements of COLLEGE. The COLLEGE will not provide INSTRUCTOR evaluation results to the SCHOOL DISTRICT.
4. The SCHOOL DISTRICT’s INSTRUCTOR shall at all times comply with the supervisory and/or instructional requirements outlined in Title 5, California Code of Regulations, section 58055, which require direct instruction by the SCHOOL DISTRICT’s INSTRUCTOR except in limited circumstances. The SCHOOL DISTRICT’s INSTRUCTOR’s responsibilities and duties as an employee of the COLLEGE shall include, but are not limited to, the following:
 - 4.1. Ensure that an instructional time of 50 minutes per class each day is expended in full compliance with the course objectives determined by the COLLEGE.
 - 4.2. Ensure the safety and well-being of students.
 - 4.3. Be in sufficient physical proximity and range of communication to provide immediate instructional supervision and control of all students in his/her classes.
 - 4.4. Attend periodic staff meetings with the COLLEGE.
 - 4.5. Regularly check and respond to communication from COLLEGE.
 - 4.6. Priority in class enrollment shall be given to students desiring to take the course for college credit towards a degree or certificate (Ed. Code § 76370). Ensure accurate and current daily student attendance records, accurate calculation of final student grades of

all students enrolled in the course for college credit, and the prompt submission of all data necessary for the calculation of FTES to the DISTRICT within 3 (three) calendar days of course completion (Ed. Code § 84500).

- 4.7. Ensure the effective use of instructional methods, technology, testing and remediation.
 - 4.8. Ensure that he/she does not have any other assigned duties during the instructional activity where multiple skill levels of students are being taught for which attendance is being claimed.
 - 4.9. Be familiar with and comply with all relevant COLLEGE policies, rules and regulations, including but not limited, to those related to student safety, grading, attendance, sexual harassment and discrimination.
 - 4.10. Provide support to SCHOOL DISTRICT students taking COLLEGE courses under CCAP agreement with COLLEGE admission and registration procedures.
5. The SCHOOL DISTRICT shall indemnify and hold harmless the COLLEGE and its authorized agents, officers, and employees against any and all claims and actions arising from the SCHOOL DISTRICT's INSTRUCTOR's or SCHOOL DISTRICT's negligent, reckless or intentional acts, errors or omissions and for any cost or expense incurred by the COLLEGE on account of any claim therefor.
 6. The COLLEGE shall provide no compensation to the SCHOOL DISTRICT's INSTRUCTOR for any services rendered pursuant to this Agreement, but compensation, as well as workers' compensation insurance, shall be the responsibility of the SCHOOL DISTRICT in accordance with its established and standard practices.
 7. This Agreement may be terminated at any time by the COLLEGE within the sole and exclusive discretion of the COLLEGE upon written notice to the SCHOOL DISTRICT and the SCHOOL DISTRICT's INSTRUCTOR. This Agreement may be terminated upon thirty (30) days' prior written notice to COLLEGE by either the SCHOOL DISTRICT or the SCHOOL DISTRICT's INSTRUCTOR within either's sole and exclusive discretion.

IN WITNESS WHEREOF, the parties hereto have executed this Agreement the day and year last written below.

INSTRUCTOR

ALLAN HANCOCK COLLEGE JOINT
COMMUNITY COLLEGE DISTRICT

Print

Print

Signature

Signature

APPENDIX B

Identification of CCAP Pathways for Course-Specific College and Career Pathway Opportunities

Pursuant to California Assembly Bill No. 288, the COLLEGE and SCHOOL DISTRICT enter into this partnership agreement to offer College and Career Pathways (CCAP) to high school students to expand dual enrollment opportunities to facilitate college and career readiness, particularly among students who may not already be college-bound or who are underrepresented in higher education.

The goal of the CCAP partnership is to offer seamless pathways from high school to community college to promote: 1) academic preparation for transfer to four-year colleges and universities; 2) completion of career and technical education programs for entry into the workforce; (3) improving high school graduation rates, and (4) helping high school pupils achieve college and career readiness.

The following pathways are included in the CCAP partnership agreement between the COLLEGE and SCHOOL DISTRICT:

Career and Technical Education:

1. This pathway includes COLLEGE courses in a Career and Technical education (“CTE”) pathway at the college level that apply to an Allan Hancock College degree or certificate in the pathway. This includes:
 - a. Naming of HIGH SCHOOL Pathway and Course Location in Sequence (Introductory, Concentrator, Capstone, or Practicum)
 - b. Naming of COLLEGE Pathway – Degree or Certificate
 - c. Identifying Career/Employment Outcomes associated with CTE Pathway
 - d. Identifying the course(s) in the Pathway to be offered under the CCAP Agreement.
2. Examples of CTE Technical Pathways include Automotive, Digital Art and Graphic Design, Culinary, Early Childhood Studies, Welding etc.

College and Career Readiness:

1. This pathway includes COLLEGE courses in career exploration and career development that prepare students in college and career planning. Successful completion of these courses will allow students to matriculate at college level in courses in a CTE pathway or General Education/California State University (“CSU”) Transfer pathway.
2. Course examples include: WEE (Work Experience); PD (Career Planning).

Preparation for Transfer:

1. California General Education Transfer Curriculum (Cal-GETC). This pathway includes COLLEGE courses which have been approved to meet the lower-division general education requirements at any CSU or University of California campus (i.e. Areas 1-6)

Improve High School Graduation Rates:

1. Student participation in college courses improves graduation rates of students who participate compared to peers who do not participate in college-level coursework.

APPENDIX C

CCAP Agreement Courses Approved for 2025 - 2026

HIGH SCHOOL DISTRICT: Lompoc Unified School District

HIGH SCHOOL SITE: Cabrillo High School

PROJECTED NUMBER OF STUDENTS TO BE SERVED: 149
TOTAL PROJECTED FTES: 27.84

CCAP Pathway	College Degree or Certificate	High School Pathway	CCAP Course Offerings		Number of Sections, High School period(s) & Times		Instructor Name & Employer of Record (AHC or HS)		Projected Number of Students	Projected FTES
			FALL	SPRING	FALL	SPRING	FALL	SPRING		
Career Technical Education	Sports Medicine – AS	Patient Care	Sports Medicine (HS)	ATH 104	high school course (TBD)	2 sections TBD	Michael Tillery (HS)	Michael Tillery (HS)	50	6.86
Career Technical Education	Media Arts: Graphic Design – CA	Graphic Production Technologies	GRPH 112	GRPH 113	1 section TBD	1 section TBD	Scott Schaller (HS)	Scott Schaller (HS)	35	14.40
Preparation for Transfer	AA-T Cal-GETC	Preparation for Cal-GETC	Economic (HS)	POLS C1000	high school course (TBD)	2 sections TBD	Linda Signal (HS)	Linda Signal (HS)	64	6.58

1. **Required:** Describe the criteria used to assess the ability of pupils to benefit from the course(s) offered:

In consultation with their SCHOOL DISTRICT counselors, students self-select a pathway based on their academic readiness and alignment of course content to students' educational and career goals. SCHOOL DISTRICT and COLLEGE faculty identified CCAP courses using the following criteria:

- a. Alignment with HIGH SCHOOL pathways and COLLEGE programs of study.
- b. Potential for course completion to accelerate students' time to completion of postsecondary degree or certificate.
- c. Potential to earn a Certificate of Training and be eligible to enter the workforce in their selected career technical pathway.
- d. Potential to work toward completion of an associate degree or an associate degree for transfer.

2. **MINIMUM QUALIFICATIONS FOR INSTRUCTION:** All instructors teaching CCAP Agreement Courses must meet the minimum qualifications for instruction in a California community college as set forth in Title 5 of the California Code of Regulations, sections 53410 and 58060 or as amended. The minimum qualifications for instruction are:

Course Name & Number	Minimum Qualifications For Instructors
ATH 104	<ul style="list-style-type: none"> • Any bachelor's degree or higher and two years of professional experience • OR any associate degree and six years of professional experience. <p>NOTE: Professional experience is required when the application possesses a master's degree. The professional experience required must be directly related to the teaching assignment.</p>
GRPH 112 GRPH 113	<ul style="list-style-type: none"> • Any bachelor's degree or higher and two years of professional experience • OR any associate degree and six years of professional experience. <p>NOTE: Professional experience is required when the application possesses a master's degree. The professional experience required must be directly related to the teaching assignment.</p>
POLS 103	<ul style="list-style-type: none"> • Master's degree in political science, government, or international relations • OR bachelor's degree in any of the above AND master's degree in economics, history, public administration, social science, sociology, and any ethnic studies, Juris Doctor Degree (J.D.) or Legum Baccalaureus (LL.B.) • OR the equivalent

3. **BOOKS AND INSTRUCTIONAL MATERIALS:** The total cost of books and instructional materials for SCHOOL DISTRICT students participating in CCAP course as part of this CCAP Agreement will be borne by SCHOOL DISTRICT. Current pricing and textbook availability is published on the COLLEGE bookstore website each semester.
4. **JOINT FACILITIES USE PROTOCOLS:** COLLEGE and SCHOOL DISTRICT shall adhere to the terms and protocols outlined in Section 19, Facilities, of the CCAP Agreement. SCHOOL DISTRICT, shall extend access and use of the following SCHOOL DISTRICT facilities:

BUILDING NAME & ADDRESS	CLASSROOM	DAYS	HOURS
Cabrillo High School 4350 Constellation Road, Lompoc, CA 93436	P-1/2	Monday - Friday	8:40am - 3:30pm
	P-7	Monday - Friday	8:40am - 3:30pm
	P-8	Monday - Friday	8:40am - 3:30pm
	SS-4	Monday - Friday	8:40am - 3:30pm

ALLAN HANCOCK JOINT COMMUNITY COLLEGE CABRILLO HIGH SCHOOL
DISTRICT

By: _____
Vice-President, Academic Affairs

By: _____
Principal

Date: _____
Date: _____

By: _____
Head Counselor

By: _____
Vice-President, Finance & Administration

Date: _____
Date: _____

APPENDIX C

CCAP Agreement Courses Approved for 2025 - 2026

HIGH SCHOOL DISTRICT:

Lompoc Unified School District

HIGH SCHOOL SITE:

Lompoc High School

PROJECTED NUMBER

OF STUDENTS TO BE SERVED: **824**

TOTAL PROJECTED FTES:

176.38

CCAP Pathway	College Degree or Certificate	High School Pathway	CCAP Course Offerings		Number of Sections, High School period(s) & Times		Instructor Name & Employer of Record (AHC or HS)		Projected Number of Students	Projected FTES
			FALL	SPRING	FALL	SPRING	FALL	SPRING		
Career Technical Education	Agricultural Science - AS	Ornamental Horticulture	AG 152	AG 156	1 section TBD	1 section TBD	Gretchen Flaherty (HS)	Gretchen Flaherty (HS)	32	6.58
Career Technical Education	Agricultural Science - AS	Agriculture Economics	AG 157	AG 158	1 section TBD	1 section TBD	Brianna Mosby (HS)	Brianna Mosby (HS)	32	6.58
Career Technical Education	Administration of Justice - AS	Public Safety	AJ 101	AJ 105	1 section After school 3:00 pm-6:00 pm	1 section After school 3:00 pm-6:00 pm	TBD (AHC)	TBD (AHC)	32	6.58
Career Technical Education	Auto Tech: Auto Engine Rebuilding - AS	Systems Diagnostics Service and Repair	Auto Service Quest (HS)	AT 100	high school course TBD	1 section TBD	TBD (HS)	Michael Johnson (HS)	28	5.76
Career Technical Education	Auto Tech: Auto Engine Rebuilding - AS	Systems Diagnostics Service and Repair	AT 313	AT 303	1 section TBD	1 section TBD	Michael Johnson (HS)	Michael Johnson (HS)	28	12.62
Preparation for Transfer	AA-T Cal-GETC	Preparation for Cal-CETC	ART 101	GEOG 102	2 sections TBD	2 sections TBD	Elizabeth Alvarez (HS)	Markie Wordley (HS)	64 cohorts rotate	13.17

Preparation for Transfer	AA-T Cal-GETC	Preparation for Cal-CE/C	GEOG 102	ART 101	2 sections TBD	2 sections TBD	Markie Wordley (HS)	Elizabeth Alvarez (HS)	64 cohorts rotate	13.17
Preparation for Transfer	AA-T Cal-GETC	Preparation for Cal-CE/C	-	BIOL 100	high school course TBD	1 section TBD	TBD (HS)	Christine Santi (HS)	32	6.58
Preparation for Transfer	AA-T Cal-GETC	Preparation for Cal-CE/C	English 11 S1 Honors (HS)	ENGL C1000	high school course TBD	3 sections TBD	Jonathan Taylor (HS)	Jonathan Taylor (HS)	96	13.17
Preparation for Transfer	AA-T Cal-GETC	Preparation for Cal-CE/C	English 12 Honors (HS)	ENGL C1001	high school course TBD	2 sections TBD	Pavel Tretyak (HS)	Pavel Tretyak (HS)	64	6.58
Career Technical Education	AA-T Cal-GETC	Preparation for Cal-CE/C	GEOG 101	AG 152	2 sections TBD	2 sections TBD	Markie Wordley (HS)	Gretchen Flaherty (HS)	64	13.17
Preparation for Transfer	AA-T Cal-GETC	Preparation for Cal-CE/C	HIST 104	HIST 105	2 sections TBD	2 sections TBD	Casey Brooks (HS)	Casey Brooks (HS)	64	13.17
Preparation for Transfer	AA-T Cal-GETC	Preparation for Cal-CE/C	HIST 107	HIST 108	3 sections TBD	3 sections TBD	Casey Brooks (HS)	Casey Brooks (HS)	96	19.75
Preparation for Transfer	AA-T Cal-GETC	Preparation for Cal-CE/C	STAT C1000	Equity Lab College Algebra (HS)	1 section TBD	high school course TBD	Tessa Ladwig (HS)	Sarah Santiago (HS)	32	5.49
Preparation for Transfer	AA-T Cal-GETC	Preparation for Cal-CE/C	Equity Lab College Algebra (HS)	STAT C1000	high school course TBD	1 section TBD	Sarah Santiago (HS)	Tessa Ladwig (HS)	32	5.49
Preparation for Transfer	AA-T Cal-GETC	Preparation for Cal-CE/C	Precalculus (HS)	MATH 141	high school course TBD	1 section TBD	Tessa Ladwig (HS)	Tessa Ladwig (HS)	32	6.58
Preparation for Transfer	AA-T Cal-GETC	Preparation for Cal-CE/C	PSYC C1000	SOC 101	1 section After school 3:00 pm-6:00 pm	1 section After school 3:00 pm-6:00 pm	TBD (AHC)	TBD (AHC)	32	6.58
Preparation for Transfer	AA-T Cal-GETC	Preparation for Cal-CE/C	SPAN 101	SPAN 102	1 section After school 3:00 pm-6:00 pm	1 section After school 3:00 pm-6:00 pm	TBD (AHC)	TBD (AHC)	32	10.97

College & Career Readiness	AA GE	College & Career Readiness	PD 110	PD 101	1 section After school 3:00 pm-6:00 pm	1 section After school 3:00 pm-6:00 pm	TBD (AHC)	TBD (AHC)	32	4.39
----------------------------	-------	----------------------------	--------	--------	--	--	-----------	-----------	----	------

1. **Required:** Describe the criteria used to assess the ability of pupils to benefit from the course(s) offered:

In consultation with their SCHOOL DISTRICT counselors, students self-select a pathway based on their academic readiness and alignment of course content to students' educational and career goals. SCHOOL DISTRICT and COLLEGE faculty identified CCAP courses using the following criteria:

- Alignment with HIGH SCHOOL pathways and COLLEGE programs of study.
- Potential for course completion to accelerate students' time to completion of postsecondary degree or certificate.
- Potential to earn a Certificate of Training and be eligible to enter the workforce in their selected career technical pathway.
- Potential to work toward completion of an associate degree or an associate degree for transfer.

2. **MINIMUM QUALIFICATIONS FOR INSTRUCTION:** All instructors teaching CCAP Agreement Courses must meet the minimum qualifications for instruction in a California community college as set forth in Title 5 of the California Code of Regulations, sections 53410 and 58060 or as amended. The minimum qualifications for instruction are:

Course Name & Number	Minimum Qualifications For Instructors
AG 152 AG 156	<ul style="list-style-type: none"> Any bachelor's degree or higher and two years of professional experience OR any associate degree and six years of professional experience. Professional experience is required when the application possesses a master's degree. The professional experience required must be directly related to the teaching assignment. OR a master's degree in agriculture, agricultural science, education with a specialization in agriculture or other agricultural area, including agricultural business, agricultural engineering, agricultural mechanics, agronomy, animal science, enology, environmental (ornamental) horticulture, equine science, forestry, natural resources, plant science, pomology, soil science, viticulture or other agriculture science OR the equivalent
AG 157	<ul style="list-style-type: none"> Any bachelor's degree or higher and two years of professional experience OR any associate degree and six years of professional experience. <p>NOTE: Professional experience is required when the application possesses a master's degree. The professional experience required must be directly related to the teaching assignment</p>

	<ul style="list-style-type: none"> • OR a master's degree in agriculture, agricultural science, education with a specialization in agriculture or other agricultural area, including agricultural business, agricultural engineering, agricultural mechanics, agronomy, animal science, enology, environmental (ornamental) horticulture, equine science, forestry, natural resources, plant science, pomology, soil science, viticulture or other agriculture science • OR master's degree in business, business management, business administration, accountancy, finance, marketing or business education • OR bachelor's degree in any of the above AND master's degree in economics, personnel management, public administration, or Juris Doctor Degree (J.D.) or Legum Baccalaureus (LL.B.) OR bachelor's degree in economics with a business emphasis AND master's in personnel management, public administration, or Juris Doctor Degree (J.D.) or Legum Baccalaureus (LL.B.) • OR the equivalent
AG 158	<ul style="list-style-type: none"> • Master's degree in agriculture, agricultural science, education with a specialization in agriculture or other agricultural area, including agricultural business, agricultural engineering, agricultural mechanics, agronomy, animal science, enology, environmental (ornamental) horticulture, equine science, forestry, natural resources, plant science, pomology, soil science, viticulture or other agriculture science • OR the equivalent
AJ 101 AJ 105	<ul style="list-style-type: none"> • Any bachelor's degree or higher and two years of professional experience • OR any associate degree and six years of professional experience. <p>NOTE: Professional experience is required when the application possesses a master's degree. The professional experience required must be directly related to the teaching assignment.</p>
ART 101	<ul style="list-style-type: none"> • Master's degree in fine arts, art, or art history • OR bachelor's degree in any of the above AND master's degree in humanities • OR the equivalent <p>NOTE: "master's degree in fine arts" as used here refers to any master's degree in the subject matter of fine arts, which is defined to include visual studio arts such as drawing, painting, sculpture, printmaking, ceramics, textiles, and metal and jewelry art, and also art education and art therapy. It does not refer to the "Master of Fine Arts" (MFA) degree when that degree is based on specialization in performing arts or dance, film, video, photography, creative writing or other nonplastic arts.</p>
AT 100 AT 303	<ul style="list-style-type: none"> • Any bachelor's degree or higher and two years of professional experience • OR any associate degree and six years of professional experience.

AT 313	NOTE: Professional experience is required when the application possesses a master's degree. The professional experience required must be directly related to the teaching assignment.
BIOL 100	<ul style="list-style-type: none"> • Master's degree in any biological science • OR bachelor's degree in any biological science AND master's degree in biochemistry, biophysics, or marine science • OR the equivalent
ENGL C1000 ENGL C1001	<ul style="list-style-type: none"> • Master's degree in English, literature, comparative literature, or composition • OR bachelor's degree in any of the above AND master's degree in linguistics, TESL, speech, or education with a specialization in reading, creative writing or journalism • OR the equivalent
GEOG 101 GEOG 102	<ul style="list-style-type: none"> • Master's degree in geography • OR bachelor's degree in geography AND master's degree in geology, history, meteorology or oceanography • OR the equivalent
HIST 104 HIST 105 HIST 107 HIST 108	<ul style="list-style-type: none"> • Master's degree in history • OR bachelor's degree in history AND master's degree in political science, humanities, geography, area studies, women's studies, social science or ethnic studies • OR the equivalent
MATH 123 MATH 141	<ul style="list-style-type: none"> • Master's degree in mathematics or applied mathematics • OR bachelor's degree in either of the above AND master's degree in statistics, physics or mathematics education • OR the equivalent
PD 101 PD 110	<ul style="list-style-type: none"> • Master's degree in counseling, rehabilitation counseling, clinical psychology, counseling psychology, guidance counseling, educational counseling, social work, career development, marriage and family therapy, or marriage, family and child counseling • NOTE: A bachelor's degree in one of the listed degrees and a license as a Marriage and Family Therapist (MFT) is an alternative qualification for this discipline • OR master's degree in education • OR the equivalent
PSY 101	<ul style="list-style-type: none"> • Master's degree in psychology

	<ul style="list-style-type: none"> • OR bachelor's degree in psychology AND master's degree in counseling, sociology, statistics, neuroscience or social work • OR the equivalent
SOC 101	<ul style="list-style-type: none"> • Master's degree in sociology • OR bachelor's degree in sociology AND master's degree in anthropology, any ethnic studies, social work, or psychology • OR the equivalent
SPAN 101 SPAN 102	<ul style="list-style-type: none"> • Master's degree in Spanish • OR bachelor's degree in Spanish AND master's degree in another language or linguistics • OR the equivalent

- 3. BOOKS AND INSTRUCTIONAL MATERIALS:** The total cost of books and instructional materials for SCHOOL DISTRICT students participating in CCAP course as part of this CCAP Agreement will be borne by SCHOOL DISTRICT. Current pricing and textbook availability is published on the COLLEGE bookstore website each semester.
- 4. JOINT FACILITIES USE PROTOCOLS:** COLLEGE and SCHOOL DISTRICT shall adhere to the terms and protocols outlined in Section 19, Facilities, of the CCAP Agreement. SCHOOL DISTRICT, shall extend access and use of the following SCHOOL DISTRICT facilities:

BUILDING NAME & ADDRESS	CLASSROOM	DAYS	HOURS
Lompoc High School 515 West College Lompoc, CA 93436	TBD	Monday-Fridays	8:30 am – 6:00 pm

ALLAN HANCOCK JOINT COMMUNITY COLLEGE
DISTRICT

By: _____
Vice-President, Academic Affairs

Date: _____

LOMPOC HIGH SCHOOL

By: _____
Principal

Date: _____

By: _____
Head Counselor

Date: _____

APPENDIX C

CCAP Agreement Courses Approved for 2025 - 2026

HIGH SCHOOL DISTRICT: Lompoc Unified School District

HIGH SCHOOL SITE: Maple High School

PROJECTED NUMBER OF STUDENTS TO BE SERVED: **40**

TOTAL PROJECTED FTES: **9.60**

CCAP Pathway	College Degree or Certificate	High School Pathway	CCAP Course Offerings		Number of Sections, High School period(s) & Times		Instructor Name & Employer of Record (AHC or HS)		Projected Number of Students	Projected FTES
			FALL	SPRING	FALL	SPRING	FALL	SPRING		
Preparation for Transfer	AA-T Cal-GETC	High School Graduation Requirements	ENGL 100	ENGL C1000	1 section 3 rd period 10:15-11:10 am	1 section 3 rd period 10:15-11:10 am	Alexandria Vine (HS)	Alexandria Vine (HS)	20	5.49
College & Career Readiness	AA GE	High School Graduation Requirements	PROD 301	PD 101	2 sections 3 rd period 10:15-11:10 am	2 sections After school 1:15 - 5:00 pm	Stacey Bean-Adams (HS)	TBD (AHC)	20	4.11

1. **Required:** Describe the criteria used to assess the ability of pupils to benefit from the course(s) offered:

In consultation with their SCHOOL DISTRICT counselors, students self-select a pathway based on their academic readiness and alignment of course content to students' educational and career goals. SCHOOL DISTRICT and COLLEGE faculty identified CCAP courses using the following criteria:

- a. Alignment with HIGH SCHOOL pathways and COLLEGE programs of study.
- b. Potential for course completion to accelerate students' time to completion of postsecondary degree or certificate.

- c. Potential to earn a Certificate of Training and be eligible to enter the workforce in their selected career technical pathway.
- d. Potential to work toward completion of an associate degree or an associate degree for transfer.

2. **MINIMUM QUALIFICATIONS FOR INSTRUCTION:** All instructors teaching CCAP Agreement Courses must meet the minimum qualifications for instruction in a California community college as set forth in Title 5 of the California Code of Regulations, sections 53410 and 58060 or as amended. The minimum qualifications for instruction are:

Course Name & Number	Minimum Qualifications For Instructors
ENGL 100 ENGL C1000	<ul style="list-style-type: none"> • Master's degree in English, literature, comparative literature, or composition • OR bachelor's degree in any of the above AND master's degree in linguistics, TESL, speech, or education with a specialization in reading, creative writing or journalism • OR the equivalent
PD 101	<ul style="list-style-type: none"> • Master's degree in counseling, rehabilitation counseling, clinical psychology, counseling psychology, guidance counseling, educational counseling, social work, career development, marriage and family therapy, or marriage, family and child counseling • NOTE: A bachelor's degree in one of the listed degrees and a license as a Marriage and Family Therapist (MFT) is an alternative qualification for this discipline • OR master's degree in education • OR the equivalent
PROD 301	<ul style="list-style-type: none"> • Master's degree in counseling, rehabilitation counseling, clinical psychology, counseling psychology, guidance counseling, educational counseling, social work, career development, marriage and family therapy, or marriage, family, and child counseling • OR the equivalent <p>NOTE: A bachelor's degree in one of the listed degrees and a license as a Marriage and Family Therapist (MFT) is an alternative qualification for this discipline</p> <ul style="list-style-type: none"> • OR master's degree in education • OR any bachelor's degree or higher and two years of professional experience in Office Technologies • OR any associate degree and six years of professional experience in Office Technologies. <p>NOTE: Professional experience is required when the application possesses a master's degree. The professional experience required must be directly related to the teaching assignment.</p>

3. **BOOKS AND INSTRUCTIONAL MATERIALS:** The total cost of books and instructional materials for SCHOOLDISTRICT students participating in CCAP course as part of this CCAP Agreement will be borne by

SCHOOL DISTRICT. Current pricing and textbook availability is published on the COLLEGE bookstore website each semester.

4. **JOINT FACILITIES USE PROTOCOLS:** COLLEGE and SCHOOL DISTRICT shall adhere to the terms and protocols outlined in Section 19, Facilities, of the CCAP Agreement. SCHOOL DISTRICT, shall extend access and use of the following SCHOOL DISTRICT facilities:

BUILDING NAME & ADDRESS	CLASSROOM	DAYS	HOURS
Maple High School 4010 Jupiter Ave Lompoc, Ca 93436	Classroom 2 Classroom 12	Mondays - Fridays	10:15 am - 11:10 am 1:15 pm - 5:00 pm

ALLAN HANCOCK JOINT COMMUNITY COLLEGE MAPLE HIGH SCHOOL DISTRICT

By: _____
Vice-President, Academic Affairs

Date: _____

By: 
Principal

Date: 5/28/25

By: 
Head Counselor

Date: 5/28/25

APPENDIX D Registration Timeline 2025 - 2026

2025-2026 Week Ranges	Process	Timeline	Type
Week 1: July 1, 2025 - July 7, 2025			
Week 2: July 8, 2025 - July 14, 2025			
Week 3: July 15, 2025 - July 21, 2025			
Week 4: July 22, 2025 - July 28, 2025			
Week 5: July 29, 2025 - August 4, 2025	Ideal	CRNs available for DualEnroll & we see bulk of forms (Would like Aug 1 deadline for CRNs)	CCAP
Week 6: August 5, 2025 - August 11, 2025	Ideal	(NonCCAP) Late Add influx, Appeal Delays, Registration Processing Delays	
Week 6: August 5, 2025 - August 11, 2025	Ideal	Firm Deadline for NonCCAP Petitions (Fall 2025)	NonCCAP
Week 6: August 5, 2025 - August 11, 2025	Ideal	(NonCCAP) Bulk of Petitions come in around this time through first day of AHC classes	NonCCAP
Week 7: August 12, 2025 - August 18, 2025		Start of Fall Term for HS Partners (Average)	
Week 8: August 19, 2025 - August 25, 2025		Start of Fall Term for AHC	
Week 8: August 19, 2025 - August 25, 2025	Actual	(NonCCAP) We accepted petitions for up until the start of classes (extended)	NonCCAP
Week 8: August 19, 2025 - August 25, 2025		Winter app opens	
Week 9: August 26, 2025 - September 1, 2025	Actual	Influx of Fall Petitions Timeframe	Both
Week 9: August 26, 2025 - September 1, 2025	Actual	(NonCCAP) Late Add influx, Appeal Delays, Registration Processing Delays	NonCCAP
Week 10: September 2, 2025 - September 8, 2025	Actual	CRNs available in DualEnroll & we see beginning of bulk of forms	CCAP
Week 10: September 2, 2025 - September 8, 2025	Ideal	Spring app opens for CCAP students	CCAP
Week 11: September 9, 2025 - September 15, 2025			
Week 12: September 16, 2025 - September 22, 2025			
Week 14: September 30, 2025 - October 6, 2025	Ideal	CCAP CRNs available (Spring 2026)	CCAP
Week 14: September 30, 2025 - October 6, 2025	Ideal	CCAP Registration Begins (Spring 2026)	CCAP
Week 14: September 30, 2025 - October 6, 2025		Spring app opens	
Week 14: September 30, 2025 - October 6, 2025	Actual	Deadline for NonCCAP Petitions (Fall 2025 Term 2)	NonCCAP
Week 15: October 7, 2025 - October 13, 2025			
Week 16: October 14, 2025 - October 20, 2025	Actual	AHC accepting NonCCAP petitions (Winter/Spring 2026)	NonCCAP
Week 16: October 14, 2025 - October 20, 2025		Class Search opens	
Week 17: October 21, 2025 - October 27, 2025			
Week 18: October 28, 2025 - November 3, 2025	Ideal	Fall processing complete for CCAP	CCAP
Week 19: November 4, 2025 - November 10, 2025	Actual	CRN available for CCAP for spring	CCAP
Week 20: November 11, 2025 - November 17, 2025	Actual	NonCCAP Registration Begins (Winter/Spring 2026)	NonCCAP
Week 20: November 11, 2025 - November 17, 2025	Actual	CCAP Registration Begins (Early Spring 2026)	CCAP
Week 21: November 18, 2025 - November 24, 2025			
Week 22: November 25, 2025 - December 1, 2025			
Week 23: December 2, 2025 - December 8, 2025	Ideal	Influx of CN Spring Petitions Timeframe	NonCCAP

FALL

SPRING

APPENDIX D Registration Timeline 2025 - 2026

Week 23: December 2, 2025 - December 8, 2025	Ideal	Deadline for NonCCAP Petitions (Winter 2026)	CCAP
Week 24: December 9, 2025 - December 15, 2025	Ideal	Bulk of CCAP registrations submitted for Spring	CCAP
Week 25: December 16, 2025 - December 22, 2024	Actual	Processing completed for Fall CCAP	CCAP
Week 25: December 16, 2025 - December 22, 2025	Actual	Start of Winter Term for AHC	
Week 26: December 23, 2025 - December 29, 2025			
Week 27: December 30, 2025 - January 5, 2026			
Week 28: January 6, 2026 - January 12, 2026	Actual	Deadline for NonCCAP Petitions (Spring 2026)	
Week 29: January 13, 2026 - January 19, 2026	Actual	Start of Spring Term for HS Partners (Average)	Both
Week 29: January 13, 2026 - January 19, 2026	Actual	Influx of CN petitions	Both
Week 30: January 20, 2026 - January 26, 2026	Actual	Start of Spring Term for AHC	
Week 31: January 27, 2026 - February 2, 2026	Actual		
Week 32: February 3, 2026 - February 9, 2026	Actual	We see bulk of our CCAP forms being turned in	CCAP
Week 33: February 10, 2026 - February 16, 2026	Actual	We see bulk of our CCAP forms being turned in	CCAP
Week 34: February 17, 2026 - February 23, 2026		CCAP Sections Identify and Created - Alicia to meet with High Schools (summer/fall 2026)	
Week 35: February 24, 2026 - March 2, 2026			
Week 36: March 3, 2026 - March 9, 2026			
Week 37: March 10, 2026 - March 16, 2026			
Week 38: March 17, 2026 - March 23, 2026			
Week 39: March 24, 2026 - March 30, 2026		CCAP Sections CRNs Complete (summer/fall 2026)	
Week 40: March 31, 2026 - April 6, 2026			
Week 41: April 7, 2026 - April 13, 2026		AHC accepting NonCCAP petitions (summer/fall 2026)	
Week 41: April 7, 2026 - April 13, 2026	Actual	Summer/Fall Class Search Opens	
Week 42: April 14, 2026 - April 20, 2026			
Week 42: April 14, 2026 - April 20, 2026		Priority Reg	
Week 43: April 21, 2026 - April 27, 2026	Ideal	Spring processing complete for CCAP	CCAP
Week 44: April 28, 2026 - May 4, 2026			
Week 45: May 5, 2026 - May 11, 2026	Ideal	<i>NonCCAP Registration Begins (Summer/Fall 2026)</i>	
Week 46: May 12, 2026 - May 18, 2026	Actual	Deadline for NonCCAP Petitions (Spring Term 2 2026)	
Week 47: May 19, 2026 - May 25, 2026	Actual	Spring processing complete for CCAP	
Week 48: May 26, 2026 - June 1, 2026			
Week 49: June 2, 2026 - June 8, 2026	Ideal	Influx of Fall Petitions Timeframe	NonCCAP
Week 50: June 9, 2026 - June 15, 2026	Actual	Start of Summer Term for AHC	
Week 51: June 16, 2026 - June 22, 2026			
Week 52: June 23, 2026 - June 29, 2026			

SPRING

FALL

**COLLEGE AND CAREER ACCESS PATHWAYS (CCAP)
PARTNERSHIP AGREEMENT
BETWEEN
THE ALLAN HANCOCK JOINT COMMUNITY COLLEGE DISTRICT
AND
ORCUTT UNION SCHOOL DISTRICT**

This College and Career Access Pathway Partnership Agreement (“CCAP Agreement”) is between the Allan Hancock Joint Community College District (“COLLEGE”) and Orcutt Union School District (“SCHOOL DISTRICT”). COLLEGE and SCHOOL DISTRICT will collectively be referred to as “PARTIES” or individually as “PARTY”.

RECITALS

WHEREAS, COLLEGE is a community college district whose mission includes providing educational programs and services that are responsive to the needs of the students and communities within the community college services area; and

WHEREAS, SCHOOL DISTRICT is a public school district located within the regional service area of the COLLEGE unless otherwise specified and agreed to as stated in AB 288, Sec. 2, Education Code section 76004, subdivision (e); and

WHEREAS, a high school (“HIGH SCHOOL”) “includes a community school, continuation high school, juvenile court school, or adult education program offering courses for high school diplomas or high school equivalency certificates” as stated in Education Code section 76004, subdivision (a)(2); and

WHEREAS, the PARTIES desire to enter into this CCAP Agreement for the purpose of offering or expanding dual enrollment opportunities, consistent with the provisions of the Education Code, for high school students “who may not already be college bound or who are underrepresented in higher education with the goal of developing seamless pathways from high school to community college for career technical education or preparation for transfer, improving high school graduation rates, and helping high school pupils achieve college and career readiness,” (Ed. Code, § 76004, subdivision (a)); and

WHEREAS, instruction will comply with the student selection standards, curriculum guidelines, recommendations and procedures promulgated by applicable law, the California Community College Chancellor’s Office and the COLLEGE; and

WHEREAS, the PARTIES desire to enter this CCAP, which sets forth their mutual rights and responsibilities and governs their relationship; and

WHEREAS, the PARTIES intend for COLLEGE to report full-time equivalent students (“FTES”) and obtain state apportionment for the subject courses given through this CCAP Agreement in

accordance with California Education Code, section 76004 and the appropriate portions of Title 5 of the California Code of Regulations; and

WHEREAS, participation in the CCAP Agreement is consistent with the core mission of California Community Colleges pursuant to Education Code section 66010.4, and that pupils participating in a CCAP partnership will not lead to enrollment displacement of otherwise eligible adults in the community college (Ed. Code, § 76004, subdivision (k)(2));

NOW, THEREFORE, PARTIES mutually agree as follows:

1. TERM OF AGREEMENT

1.1. **Effective Date and Duration.** The term of this CCAP Agreement shall be effective on **July 1, 2025**, and continue in effect until **June 30, 2026**, or until duly modified or terminated by the PARTIES in accordance with Section 1.2 of this CCAP Agreement.

1.2. Early Termination.

- a. This agreement may be terminated by either PARTY without cause or for any reason upon giving at least sixty (60) days prior written notice to the other PARTY. Any students currently enrolled in COLLEGE courses under this CCAP Agreement shall be allowed to complete those courses prior to the termination of this CCAP Agreement.
- b. This CCAP Agreement may be terminated by either PARTY with cause if another PARTY fails to comply with the insurance or indemnification requirements or otherwise commits a material breach. Termination will be effective no sooner than 15 calendar days after a written demand to cure is provided and the PARTY fails to cure. This remedy is in addition to any other remedy which may be provided for by law.

1.3. **The CCAP Agreement Appendix.** This CCAP Agreement outlines the terms of the Agreement.

- a. The CCAP Agreement Appendix shall specify CCAP Agreement Courses as well as additional details regarding, but not be limited to, the total number of high school students to be served and the total number of full-time equivalent students (“FTES”) projected to be claimed by the community college district for those students; the scope, nature, time, location, and listing of community college courses to be offered; and criteria to assess the ability of pupils to benefit from those courses:

Appendix A: Agreement with Instructor.

Appendix B: Identification of CCAP Pathways for Course-Specific College and Career Pathway Opportunities.

Appendix C: CCAP Agreement Courses Approved for 2025-2026.

Appendix D: Registration Timeline 2025-2026.

- b. The CCAP Agreement Appendix C shall be reviewed and approved annually by both PARTIES by a duly adopted written amendment to this Agreement.

1.4. **Points of contact and Educational Administrators** are as follows:

COLLEGE: Thomas Lamica, dean, academic affairs
 SCHOOL DISTRICT: Dr. Holly Edds, superintendent
 HIGH SCHOOL SITE: Rhett Carter, principal; Josh Ostini, vice-principal

(Ed. Code, § 76004, subdivision (c)(2))

- 1.5. A copy of the COLLEGE and SCHOOL DISTRICT CCAP Agreement shall be filed with the office of the Chancellor of the California Community Colleges and with the California Department of Education before the start of the CCAP partnership. (Ed. Code, § 76004, subdivision (c)(3).)
- 1.6. COLLEGE and SCHOOL DISTRICT shall present this CCAP agreement at an open public meeting of their respective governing boards, allowing for public comments prior to consideration for approval or disapproval of this CCAP agreement. (Ed. Code, § 76004, subdivision (b)(2).)

2. DEFINITIONS

- 2.1. **CCAP Agreement Courses.** CCAP Agreement Courses offered as part of this CCAP Agreement shall be community college courses acceptable towards a career technical education credential or certificate, preparation for transfer, or appropriate to improve high school graduation rates or help high school pupils achieve college and career readiness. (Ed. Code § 76004, subdivision (a).) All community college courses offered at the SCHOOL DISTRICT have been approved in accordance with the policies and guidelines of COLLEGE and applicable law. Courses offered at the COLLEGE that are open to the public for enrollment fall outside of this CCAP agreement and are subject to all conditions and rules of the COLLEGE.
- 2.2. **Pupil or Student Fees.** Pupil or Student is defined as a resident or nonresident student attending HIGH SCHOOL in California. SCHOOL DISTRICT pupils enrolled in a course offered through this CCAP Agreement shall not be assessed any fee that is prohibited by Education Code section 49011 (Ed. Code § 76004, subdivision (f)), including a fee charged to a student or a student's parent or guardian as a condition for course registration or for textbooks, supplies, materials and equipment needed to participate in the course. Students who are enrolled in a combination of CCAP and regular credit college courses will be subject to all fees assessed for the regular credit college enrollment for the regular credit college courses.

3. STUDENT ELIGIBILITY, SELECTION AND ENROLLMENT, ADMISSION, REGISTRATION, MINIMUM SCHOOL DAY

- 3.1. **Student Eligibility.** Students who "may not already be college bound or who are underrepresented in higher education, with the goal of developing seamless pathways from

high school to community college for career technical education or preparation for transfer, improving high school graduation rates, or helping high school pupils to achieve college and career readiness" and "underachieving students, those from groups underrepresented in postsecondary education, those who are seeking advanced studies while in high school, and those seeking a career technical education credential or certificate" are eligible to participate in CCAP courses hosted at a SCHOOL DISTRICT site. (Education Code § 76004, subdivision (a); Assembly Bill 288 (2015) Section I, subdivision (d))

- 3.2. **Student Selection and Enrollment.** Enrollment shall be open to all eligible students as part of the CCAP Agreement who have been admitted to the COLLEGE and who meet all applicable prerequisites. Student selection criteria will be further specified in the CCAP Agreement Appendix C. Applicable prerequisite courses, training, or experience and standards required as preparation for courses offered through the CCAP Agreement will be determined by COLLEGE and shall be in compliance with applicable law and COLLEGE standards and policies.
- 3.3. **College Admission and Registration.** Procedures for students participating in the CCAP Agreement shall be governed by the COLLEGE and shall be in compliance with the admissions and registration guidelines outlined in applicable law and COLLEGE policy.
- 3.4. **Records of Student Attendance.** All records of student attendance and achievement shall be submitted to COLLEGE periodically using the COLLEGE student information system or upon demand and shall be maintained by COLLEGE.
- 3.5. **Priority Enrollment.** Students enrolling in a CCAP course will have priority enrollment by virtue of their status. High school students enrolling in non-CCAP college courses will not be eligible for priority registration.
- 3.6. **Physical Education Courses.** As part of a CCAP Agreement, a participating community college district shall not provide physical education course opportunities to high school students or any other course opportunities that do not assist in the attainment of the goals associated with career technical education or preparation for transfer, improving high school graduation rates, or helping high school students achieve career and college readiness. (Ed. Code § 76004, subdivision (d)).
- 3.7. **Maximum Units.** Students participating under a CCAP Agreement may enroll in up to a maximum of 15 units per term, without exception, if all the following conditions specified in Assembly Bill 288, Sec. 2 (p)(1)(2)(3) are satisfied:
 - a. The units constitute no more than four community college courses per term.
 - b. The units are part of an academic program that is part of a CCAP partnership agreement established pursuant to this article.
 - c. The units are part of an academic program that is designed to award students both a high school diploma and an associate degree or a certificate or credential.
- 3.8. **Minimum School Day.** The SCHOOL DISTRICT shall certify that it shall teach SCHOOL DISTRICT students participating as part of a CCAP Agreement no less than the number of instructional minutes required to complete a minimum school day pursuant to Education Code sections 46141 and 46142.
- 3.9. **Enrollment Restriction.** COLLEGE reserves the right to block students from enrolling in any courses for students who incur an unpaid debt for a non-CCAP class at the college. COLLEGE agrees to remove the enrollment block when debt is paid in full.

4. COLLEGE APPLICATION PROCEDURE

- 4.1. The COLLEGE will be responsible for processing student applications.
- 4.2. The COLLEGE will provide the necessary admission and registration forms and procedures, and both COLLEGE and SCHOOL DISTRICT will jointly ensure that each applicant accepted has met all the enrollment requirements.
- 4.3. The SCHOOL DISTRICT agrees to assist COLLEGE in the admission and registration of SCHOOL DISTRICT students as may be necessary and requested by COLLEGE.

5. PARTICIPATING STUDENTS

- 5.1. The total cost of books and instructional materials for SCHOOL DISTRICT students who enroll in a COLLEGE course offered as part of this CCAP Agreement will be borne by SCHOOL DISTRICT.
- 5.2. Both COLLEGE and SCHOOL DISTRICT will ensure that ancillary and support services are accessible to students (e.g., Tutoring.)
- 5.3. A student taking courses under this CCAP Agreement with an Individual Education Plan or 504 Plan with the SCHOOL DISTRICT may request accommodation for his or her disability to participate in the educational programs and activities required by the COURSE and COLLEGE. Accommodation required by state law or SCHOOL DISTRICT policy will be provided through SCHOOL DISTRICT in consultation with the COLLEGE Learning Assistance Program (LAP) Office. Students requesting services by the LAP office will need to follow the standard process for requesting accommodations.

6. CCAP AGREEMENT COURSES

- 6.1. The COLLEGE may limit enrollment in a community college course solely to eligible high school students if the course is offered at a high school campus during the regular school day and the community college course is offered pursuant to this CCAP Agreement.
- 6.2. The COLLEGE is responsible for all courses and educational programs offered as part of CCAP Agreement .
- 6.3. The scope, nature, time, location, and listing of courses offered by a COLLEGE shall be determined by COLLEGE in consultation with the SCHOOL DISTRICT and with the approval of the COLLEGE and will be recorded in the Appendix C to this CCAP Agreement.
- 6.4. Courses offered as part of a CCAP Agreement shall be jointly selected and approved by COLLEGE and SCHOOL DISTRICT.
- 6.5. Courses offered as part of this CCAP Agreement shall have a minimum enrollment of fifteen (15) students.
- 6.6. The SCHOOL DISTRICT confirms that each approved CCAP course is held for no less than 50 minutes each class day in full compliance with the course objectives determined by the COLLEGE.
- 6.7. Degree and certificate programs that are included in the CCAP agreement must have been approved by the California Community College Chancellor's Office and courses offered at the SCHOOL DISTRICT shall adhere to the official course outline of record and the student

- learning outcomes established by the associated academic department within the COLLEGE, approved by the COLLEGE Academic Policy & Planning (AP&P) Committee and submitted to the Chancellor's Office. Course outlines will be provided to the SCHOOL DISTRICT.
- 6.8. Courses must meet the number of hours sufficient to meet the stated performance objectives as outlined in the course outlines provided to the SCHOOL DISTRICT on a semester basis.
 - 6.9. Courses offered at the SCHOOL DISTRICT as part of this CCAP Agreement shall be of the same quality and rigor as those offered on the COLLEGE campus and shall be in compliance with COLLEGE academic standards.
 - 6.10. Courses offered as part of this CCAP Agreement will comply with all applicable regulations, policies, procedures, prerequisites, and standards applicable to the COLLEGE as well as any corresponding policies, practices, and requirements of the SCHOOL DISTRICT. In the event of a conflict between the COLLEGE course related regulations, policies, procedures, prerequisites and standards and SCHOOL DISTRICT policies, practices and requirements, the COLLEGE regulations, policies, procedures, prerequisites, and standards, shall prevail.
 - 6.11. A student's withdrawal prior to completion of a course offered as part of this CCAP Agreement shall be in accordance with COLLEGE guidelines, policies, pertinent statutes and regulations.
 - 6.12. Supervision and evaluation of students enrolled in courses offered as part of this CCAP Agreement shall be in accordance with COLLEGE guidelines, policies, pertinent statutes and regulations.
 - 6.13. COLLEGE has the sole right to control and direct the instructional activities for all CCAP Agreement courses and all instructors, including those who are SCHOOL DISTRICT employees.
 - 6.14. This CCAP Agreement certifies that any remedial course taught by community college faculty at a partnering high school campus shall be offered only to high school students who do not meet their grade level standard in math, English, or both on an interim assessment in grade 10 or 11, as determined by the partnering SCHOOL DISTRICT, and shall involve collaborative effort between the SCHOOL DISTRICT and the COLLEGE faculty to deliver an innovative remediation course as an intervention in the student's junior or senior year to ensure the student is prepared for college-level work upon graduation.
 - 6.15. CCAP Agreement Courses outlined in Appendix C shall be updated annually and approved before the start of each academic year.

7. INSTRUCTORS

- 7.1. All instructors teaching COLLEGE courses offered as part of this CCAP Agreement must meet the minimum qualifications for instruction in a California community college as set forth in Title 5 California Code of Regulations, Sections 53410 and 58060 or as amended.
- 7.2. The CCAP Agreement Appendix C shall specify which participating SCHOOL DISTRICT or COLLEGE will be the employer of record for purposes of assignment monitoring and reporting to the county office of education.
- 7.3. This CCAP Agreement specifies that the SCHOOL DISTRICT will assume reporting

responsibilities pursuant to applicable federal teacher quality mandates.

- 7.4. Instructors who teach COLLEGE courses offered as part of this CCAP Agreement must provide the supervision and control reasonably necessary for the protection of the health and safety of students and may not have any other assigned duty during the instructional activity.
- 7.5. Instructors who teach COLLEGE courses shall comply with the fingerprinting requirements set forth in Education Code section 45125 or as amended and the tuberculosis testing and risk assessment requirements of California Health and Safety Code section 121525 or as amended. In addition to any other prohibition or provision, no person who has been convicted of a violent or serious felony shall be eligible to teach any courses offered as part of this CCAP Agreement or otherwise provide services on a SCHOOL DISTRICT site. SCHOOL DISTRICT shall immediately notify COLLEGE if an instructor is charged with an offense prohibited by Education Code sections 44010 or 44011.
- 7.6. Prior to teaching, faculty provided by the SCHOOL DISTRICT shall participate in required discipline-specific training and orientation from COLLEGE regarding, but not limited to, course curriculum, assessment criteria, pedagogy, course philosophy, testing and grading procedures record keeping, and other instructional responsibilities. Such training shall be approved and provided by the COLLEGE.
- 7.7. Prior to teaching, instructors provided by the COLLEGE may receive training and orientation from SCHOOL DISTRICT regarding, but not limited to, SCHOOL DISTRICT policies, practices, and requirements. Such training may be approved and provided by the SCHOOL DISTRICT.
- 7.8. Faculty provided by the SCHOOL DISTRICT are eligible to participate in professional development activities sponsored by the COLLEGE as required by the terms and condition of the contract and shall be encouraged to participate in ongoing collegial interaction to include, but not limited to, addressing course content, course delivery, assessment, evaluation, and/or research and development in the field.
- 7.9. The COLLEGE shall evaluate faculty performance for the college courses using the adopted evaluation of process and standards for faculty of the COLLEGE, subject to the approval of COLLEGE.
- 7.10. The COLLEGE and SCHOOL DISTRICT will work collaboratively to identify instructors from SCHOOL DISTRICT who may meet minimum qualification requirements or local equivalency standards to teach a COLLEGE course and encourage them to apply for consideration. Instructors will be required to go through the COLLEGE screening process for possible selection and assignment to the course.
- 7.11. The SCHOOL DISTRICT teachers approved to teach COLLEGE courses remain employees of the SCHOOL DISTRICT, subject to the authority of the SCHOOL DISTRICT, but will also be subject to the authority of COLLEGE specifically with regard to their duties as COLLEGE instructors, pursuant to the terms of Appendix A.
- 7.12. The COLLEGE shall determine the number of instructors, the ratio of instructors to students, and the subject areas of instruction.
- 7.13. Faculty provided by the SCHOOL DISTRICT who do not comply with the policies, regulations, standards, and expectations of the COLLEGE shall be ineligible to teach college courses under this CCAP Agreement.
- 7.14. SCHOOL DISTRICT teachers approved to teach CCAP Courses under this CCAP

Agreement must submit grades to both the COLLEGE and SCHOOL DISTRICT using the COLLEGE student information system by the established timeline (Appendix D).

- 7.15. SCHOOL DISTRICT teachers approved by the COLLEGE shall sign an Agreement with the Instructor (Appendix A) prior to the start of each academic year.
- 7.16. SCHOOL DISTRICT teachers approved by the COLLEGE shall provide support to high school students taking COLLEGE courses under CCAP agreement with COLLEGE admission and registration procedures.

8. ASSESSMENT OF LEARNING AND CONDUCT

- 8.1. Students enrolled in COLLEGE courses offered as part of this CCAP Agreement at the SCHOOL DISTRICT shall be held to the same standards of achievement as students in courses taught on the COLLEGE campus.
- 8.2. Students enrolled in COLLEGE courses offered as part of this CCAP Agreement at the SCHOOL DISTRICT shall be held to the same grading standards as those expected of students in courses taught on the COLLEGE campus.
- 8.3. Students enrolled in COLLEGE courses offered as part of this CCAP Agreement at the SCHOOL DISTRICT shall be assessed using the same methods (e.g., papers, portfolios, quizzes, labs, etc.) as students in courses taught on the COLLEGE campus.
- 8.4. Students enrolled in COLLEGE courses offered as part of this CCAP Agreement at the SCHOOL DISTRICT shall be held to the same behavioral standards as those expected of students in courses taught on the COLLEGE campus.

9. LIAISON AND COORDINATION OF RESPONSIBILITIES

- 9.1. The COLLEGE shall appoint an educational administrator who will serve as point of contact to facilitate coordination and cooperation between COLLEGE, SCHOOL DISTRICT, and HIGH SCHOOL in conformity with COLLEGE policies and standards. (Ed. Code, § 76004, subd. (c)(2).) Among other things, the COMMUNITY COLLEGE DISTRICT Educational Administrator and the SCHOOL DISTRICT Educational Administrator described in Section 9.2, shall collaborate to determine the process for timely receiving, investigating, and remediating complaints of sexual misconduct or other conduct covered by Title IX of the Education Amendments of 1972 alleged to have occurred in or related to the CCAP program.
- 9.2. The SCHOOL DISTRICT shall appoint an educational administrator who will serve as point of contact to facilitate coordination and cooperation between SCHOOL DISTRICT, COLLEGE, HIGH SCHOOL in conformity with SCHOOL DISTRICT policies and standards.
- 9.3. This CCAP Agreement requires an annual report to the office of the Chancellor of the California Community Colleges by COLLEGE and SCHOOL DISTRICT. COLLEGE shall complete and file the Apportionment Attendance Report (CCFS-320); SCHOOL DISTRICT agrees to provide the following information, when requested by COLLEGE, in accordance with AB 288 Section 2, Education Code Section 76004:
 - a. The total number of high school students by school site enrolled in each partnership, aggregated by gender and ethnicity, and reported in compliance with all applicable state and federal privacy laws.

- b. The total number of community college courses by course category and type and by school site enrolled in by CCAP partnership participants.
- c. The total number and percentage of successful course completions, by course category and type and by school site, of CCAP partnership participants.
- d. The total number of full-time equivalent students generated by CCAP partnership community college district participants.

10. DISPUTES

10.1. COLLEGE and SCHOOL DISTRICT recognize that, from time to time, disputes may arise between COLLEGE employees or students and SCHOOL DISTRICT employees or students. When such disputes arise, COLLEGE and SCHOOL DISTRICT shall collaborate and use their best efforts to resolve them informally. Where informal resolution is not successful or the PARTIES must address a formal inter-agency complaint, the following process will be utilized to resolve the matter.

- a. The PARTY receiving the complaint will timely notify the other, and promptly provide the other PARTY with any written complaint received.
- b. The Educational Administrators will review the complaint to determine, based on the nature of the complaint, whether any statutory or regulatory timelines or other procedural requirements apply, including but not limited to:
 - 10.1.b.1. Whether COLLEGE is required to investigate the complaint to the State Chancellor pursuant to Title 5 of the California Code of Regulations.
 - 10.1.b.2. Whether, based on the nature of the complaint, the complainant is entitled to any rights or protections with regard to how the complaint is handled, pursuant to Title 5 or applicable state or federal laws, including but not limited to Title IX of the Education Amendments of 1972.
 - 10.1.b.3. If either Educational Administrator finds such rights to exist, he or she shall notify the other Educational Administrator, and COLLEGE and SCHOOL DISTRICT shall cooperate as needed in carrying out these requirements. It is understood that such requirements may include but are not limited to conducting a formal investigation within regulatory timelines or the implementation of interim safety measures for the complainant.
- c. Within a reasonable time, either PARTY receiving the complaint, the PARTIES will discuss the nature and severity of the allegations and come to a mutual agreement regarding the need for and scope of any investigation required. If it is agreed that a formal investigation is required, the PARTIES will mutually agree upon an investigator, who may be an outside investigator, or qualified employee of COLLEGE or SCHOOL DISTRICT. If the PARTIES agree to have the matter investigated internally by either a COLLEGE or SCHOOL DISTRICT employee, the other PARTY may designate an employee to attend all witness interviews. Where it is determined that an outside investigator will be used, the cost will be divided between the PARTIES.
- d. If, despite the good faith effort of the PARTIES, they are unable to agree on a process for investigating the complaint, the PARTY whose employee/student is the subject of the complaint will determine the process.

- e. The COLLEGE and SCHOOL DISTRICT will cooperate in any investigation initiated and make its employees available to the investigator.
- f. Interviews of COLLEGE and SCHOOL DISTRICT employees shall comply with any rights and protections afforded to them under an applicable collective bargaining agreement or state or federal law, including but not limited to the right to have a representative present during an interview that could lead to discipline.
- g. The investigator will prepare a report that will be provided to both PARTIES setting forth findings as to the allegations and the basis for the findings.
- h. The COLLEGE and SCHOOL DISTRICT shall share any and all materials from the investigation, unless sharing would cause a PARTY to violate confidentiality or privacy laws.
- i. The COLLEGE and SCHOOL DISTRICT have sole discretion in determining any disciplinary measures to be imposed against their respective employees or students.
- j. Regardless of any disciplinary measures taken by the COLLEGE or SCHOOL DISTRICT against its respective employees or students, the other PARTY retains the right to have the subject of a sustained complaint removed from participating in or providing services for the program that is the subject of this CCAP Agreement.

11. APPORTIONMENT

- 11.1. COLLEGE shall include the students enrolled in a CCAP Agreement course in its report of full-time equivalent students (FTES) for purposes of receiving state apportionments when the course(s) complies with current requirements for dual enrollment under applicable California law.
- 11.2. For purposes of allowances and apportionments from Section B of the State School Fund, a community college district conducting a closed course on a high school campus shall be credited with those units of full-time equivalent students attributable to the attendance of eligible high school pupils.
- 11.3. The COLLEGE shall not receive a state allowance or apportionment for an instructional activity for which the SCHOOL DISTRICT has been, or shall be, paid an allowance or apportionment. (Ed. Code § 76004, subdivision (o)(2)).
- 11.4. The attendance of a SCHOOL DISTRICT pupil at the COLLEGE as a special part-time or full-time student pursuant to this section is authorized attendance for which the COLLEGE shall be credited or reimbursed pursuant to Section 48802 or 76002, provided that no school district has received reimbursement for the same instructional activity.

12. CERTIFICATIONS

- 12.1. The SCHOOL DISTRICT certifies that:
 - a. The direct education costs of the courses offered as part of this CCAP Agreement are not fully funded through other sources.
 - b. It agrees and acknowledges that the COLLEGE will claim apportionment for the SCHOOL DISTRICT students enrolled in community college course(s) under this CCAP Agreement.

- c. Any COLLEGE instructor teaching a course at the SCHOOL DISTRICT has not displaced or resulted in the termination of an existing high school teacher teaching the same course on that high school campus.

12.2. The COLLEGE certifies that:

- a. A community college course offered for college credit at the participating SCHOOL DISTRICT does not reduce access to the same course offered at the partnering COLLEGE.
- b. The COLLEGE has not received full compensation for the direct education costs for the conduct of the courses offered as part of this CCAP Agreement from other sources.
- c. The Agreement is consistent with the core mission of the COLLEGE pursuant to Section 66010.4 and students participating in this CCAP Agreement will not lead to displacement of otherwise eligible adults at the COLLEGE.
- d. A qualified SCHOOL DISTRICT instructor teaching a course offered for college credit at a high school campus has not displaced or resulted in the termination of an existing COLLEGE faculty member teaching the same course at the partnering community college campus.

12.3. The PARTIES certify that:

- a. Any COLLEGE instructor teaching a course on a SCHOOL DISTRICT campus has not been convicted of any sex offense as defined in Education Code section 44010 or as amended, or any controlled substance offense as defined in Education Code section 44011 or as amended.
- b. The SCHOOL DISTRICT and COLLEGE comply with local collective bargaining agreements and all state and federal reporting requirements regarding the qualifications of the teacher or faculty member teaching a CCAP Agreement course offered for high school credit. (AB288 Sec. 2 (I).)

13. PROGRAM IMPROVEMENT

- 13.1. The COLLEGE and the SCHOOL DISTRICT may annually conduct surveys of participating SCHOOL DISTRICT pupils, instructors, principals, and school counselors for the purpose of informing practice, adjusting, and improving the quality of courses offered as part of this CCAP Agreement.

14. RECORDS

- 14.1. Permanent records of student attendance, grades and achievement will be maintained by both the SCHOOL DISTRICT and COLLEGE for SCHOOL DISTRICT students who enroll in course(s) offered as part of this CCAP Agreement. Permanent records of student enrollment, grades, and achievement for COLLEGE students shall be maintained by COLLEGE.
- 14.2. Each PARTY shall maintain records pertaining to this CCAP Agreement as may be required by federal and state law. Each PARTY may review and obtain a copy of the other

PARTY'S pertinent records subject to federal and state privacy statutes.

- 14.3. SCHOOL DISTRICT instructors will submit grades to the COLLEGE when due according to the COLLEGE schedule per section 7.14. The SCHOOL DISTRICT will include all criteria identified by the COLLEGE for grading purposes.
- 14.4. COLLEGE may provide the SCHOOL DISTRICT with a report on participating students' final grades after each term.

15. CCAP AGREEMENT DATA MATCH AND REPORTING

- 15.1. COLLEGE and SCHOOL DISTRICT shall ensure operational protocols consistent with the collection of participating student data and the timely submission of the data.
- 15.2. COLLEGE shall report all program and participating student data to the office of the Chancellor of the California Community Colleges.

16. DATA SHARING

- 16.1. COLLEGE and SCHOOL DISTRICT may share confidential student data for the purposes of evaluating the educational services provided under this CCAP agreement and for evaluating student performance pursuant to participating in CCAP courses. Any data shared will be for research and analytical purposes aimed at understanding student performance and improving applicable federal and state laws concerning access to and confidentiality of student record information as described in Section 17 of this agreement.

17. PRIVACY OF STUDENT RECORDS

- 17.1. COLLEGE and SCHOOL DISTRICT understand and agree that education records of students enrolled in a CCAP course and personally identifiable information contained in those educational records are subject to the Family Educational Rights and Privacy Act (FERPA) 20 U.S.C. § 1232g; 34 C.F.R. Part 99, including the disclosure provisions of § 99.30 and state law as outlined in Education Code section 49064 and section 49076). COLLEGE and SCHOOL DISTRICT agree to hold all student education records generated pursuant to this CCAP Agreement in strict confidence and further agree not to disclose such records except as authorized by applicable law or regulation for COLLEGE records or by the parent or guardian's prior written consent for HIGH SCHOOL records. (34 C.F.R. § 99.33 (a), (b); 34 C.F.R. § 99.34(b) and Education Code §§ 49064 and 49076.)
- 17.2. **Limitation on Use.** COLLEGE and SCHOOL DISTRICT shall use each student education record that they may receive pursuant to this CCAP Agreement solely for purposes consistent with their authority to access that information pursuant to Federal and State law, as may be as applicable. (34 C.F.R. § 99.31, 34 C.F.R. § 99.34, and Education Code § 49076.)
- 17.3. **Recordkeeping Requirements.** COLLEGE and SCHOOL DISTRICT shall comply with the requirements governing maintenance of records of each request for access to and each disclosure of student education records set forth under Title 34, Code of Federal Regulations § 99.32 and under Education Code § 49064 as applicable.
- 17.4. **Acknowledgement of Receipt of Notice of FERPA Regulations.** By signature of its authorized representative or agent on this Agreement, COLLEGE and SCHOOL DISTRICT hereby acknowledges that it has been provided with the notice required under

34 C.F.R. § 99.33(d) that it is strictly prohibited from re-disclosing student education records to any other person or entity except as authorized by applicable law or regulation. Parent or guardian requests for information will need to be addressed directly by the HIGH SCHOOL or SCHOOL DISTRICT personnel.

18. REIMBURSEMENT

18.1. The SCHOOL DISTRICT shall invoice the COLLEGE no later than 30 (thirty) days after the start of each term for the instructional services provided through this CCAP agreement as follows:

- a. For courses taught by COLLEGE-approved SCHOOL DISTRICT teachers and COLLEGE instructors on HIGH SCHOOL campuses during regular high school hours rendered at the rate of \$1,000.00 per course unit delivered to CCAP students.

Example: 3 CCAP courses @ 3 units each = 9 units x \$1,000.00 = \$9,000.00

18.2. The COLLEGE shall make payment to the SCHOOL DISTRICT within 30 days of receiving the invoice for instructional services rendered.

18.3. The COLLEGE is required to report to the state the percentage of funds paid to an agency to the SCHOOL DISTRICT that will provide direct instruction on behalf of the college as part of the CCAP partnership agreement. The SCHOOL DISTRICT will use 100% of all funds received from Allan Hancock College in fulfillment of this agreement to pay for direct instructional costs. (Ed. Code § 84632).

19. FACILITIES

19.1. The SCHOOL DISTRICT will provide adequate classroom space at its facilities or other mutually agreed upon locations to conduct the instruction and do so without charge to COLLEGE or students. SCHOOL DISTRICT agrees to clean, maintain, and safeguard SCHOOL DISTRICT's premises. SCHOOL DISTRICT warrants that its facilities are safe and compliant with all applicable buildings, fire, and safety codes.

19.2. The SCHOOL DISTRICT will furnish, at its own expense, all course materials, specialized equipment, books and other necessary equipment for all SCHOOL DISTRICT students. The parties understand that such equipment and materials are the SCHOOL DISTRICT's sole property.

19.3. The SCHOOL DISTRICT facilities may be used by COLLEGE for COLLEGE course offerings before or after regular high school schedule at no additional cost. Prior approval by the SCHOOL DISTRICT is required. COLLEGE courses offered before or after the regular high school schedule will be open to the public.

20. INDEMNIFICATION

20.1. The SCHOOL DISTRICT agrees to and shall indemnify, save and hold harmless the COLLEGE, and its governing board, officers, employees, administrators, independent

contractors, subcontractors, agents and other representatives from any and all claims, demands, liabilities, costs, expenses, damages, causes of action, losses, and judgments, arising out of SCHOOL DISTRICT's performance of this CCAP Agreement. The obligation to indemnify shall extend to all claims and losses that arise out of SCHOOL DISTRICT's or its trustees', officers', agents', or employees' negligence, wrongful acts or omissions, or willful misconduct related to this CCAP Agreement or performance of this CCAP Agreement. The provisions of this section shall survive the termination or expiration of this CCAP Agreement.

20.2. The COLLEGE agrees to and shall indemnify, save and hold harmless the SCHOOL DISTRICT and its governing board, officers, employees, administrators, independent contractors, subcontractors, agents and other representatives from any and all claims, demands, liabilities, costs, expenses, damages, causes of action, losses, and judgments, arising out of COLLEGE'S performance of this CCAP Agreement. The obligation to indemnify shall extend to all claims and losses that arise out of COLLEGE'S or its trustees', officers', agents', or employees' negligence, wrongful acts or omissions, or willful misconduct related to this CCAP Agreement or performance of this CCAP Agreement. The provisions of this section shall survive the termination or expiration of this CCAP Agreement.

21. INSURANCE

21.1. The SCHOOL DISTRICT, in order to protect the COLLEGE, its agents, employees and officers against claims and liability for death, injury, loss and damage arising out of or in any manner connected with the performance and operation of the terms of this CCAP Agreement, shall secure and maintain in force during the entire term of this CCAP Agreement, insurance coverage or an approved program of self-insurance in the amount of not less than ONE MILLION DOLLARS (\$1,000,000) per incident and TWO MILLION DOLLARS (\$2,000,000) general aggregate for personal injury, bodily injury, death, and property and other damage, with an admitted California insurer duly licensed to engage in the business of insurance in the State of California, or public entity risk management Joint Powers Authority, authorized to provide public liability and property damage insurance in the state of California. Said policy of insurance, insurance coverage through a public entity risk management JPA, or program of self-insurance shall expressly name the COLLEGE, its agents, employees and officers as an additional insured for the purposes of this CCAP Agreement. A certificate of insurance including such endorsement shall be furnished to the COLLEGE.

21.2. The COLLEGE, in order to protect the SCHOOL DISTRICT, its agents, employees and officers against claims and liability for death, injury, loss and damage arising out of or in any manner connected with the performance and operation of the terms of this CCAP Agreement, shall secure and maintain in force during the entire term of this CCAP Agreement, insurance coverage or an approved program of self-insurance in the amount of not less than ONE MILLION DOLLARS (\$1,000,000) per incident and TWO MILLION DOLLARS (\$2,000,000) general aggregate for personal injury, bodily injury, death, and property and other damage, with an admitted California insurer duly licensed to engage in the business of insurance in the State of California, or public entity risk management Joint Powers Authority, authorized to provide public liability and property damage insurance in the State

of California. Said policy of insurance, insurance coverage through a public entity risk management JPA or program of self-insurance shall expressly name the SCHOOL DISTRICT, its agents, employees and officers as an additional insured for the purposes of this CCAP Agreement. A certificate of insurance including such endorsement shall be furnished to the SCHOOL DISTRICT.

- 21.3. For the purpose of Workers' Compensation, SCHOOL DISTRICT shall be the "primary employer" for all its employees who perform services as instructors and support staff. SCHOOL DISTRICT shall be solely responsible for processing, investigating, defending, and paying all workers' compensation claims by their respective SCHOOL DISTRICT employees made in connection with performing services and receiving instruction under this CCAP Agreement. SCHOOL DISTRICT agrees to hold harmless, indemnify, and defend COLLEGE, its directors, officers, agents, and employees from any liability resulting from its failure to process, investigate, defend, or pay any workers' compensation claims by SCHOOL DISTRICT employees connected with providing services under this CCAP Agreement.

22. NON-DISCRIMINATION

- 22.1. Neither the SCHOOL DISTRICT nor the COLLEGE shall discriminate on the basis of race or ethnicity, gender, nationality, physical or mental disability, sexual orientation, religion, or any other protected class under California State or federal law.

23. NOTICES

- 23.1. Any and all notices required to be given hereunder shall be deemed given when personally delivered or deposited in the U.S. Mail, postage to be prepaid, to the following addresses:

Allan Hancock College Joint Community College District
800 S. College Drive
Santa Maria, CA 93460
Attn: Dennis Curran

Orcutt Union School District
500 Dyer Street
Orcutt, CA 93455
Attn: Dr. Holly Edds

24. MODIFICATION AND AMENDMENT

- 24.1. Appendix A through D to this CCAP Agreement is incorporated by this reference into this CCAP Agreement.
- 24.2. This CCAP Agreement and Appendix A through D to this CCAP Agreement set forth the entire agreement between the PARTIES relating to the subject matter of this CCAP Agreement. This CCAP Agreement and Appendix A through D to this CCAP Agreement supersede any prior agreements, promises, negotiations, or representations, express or

implied, oral or written, not included in this CCAP Agreement and Appendix A through D to this CCAP Agreement.

24.3. This Agreement may be amended only with the mutual consent of the Parties. All amendments must be in writing and must be approved by the Parties' respective governing Boards.

25. GOVERNING LAWS

25.1. This CCAP Agreement will be governed by and construed in accordance with California law, and the venue of any action or proceeding in connection with this CCAP Agreement shall be Santa Barbara County, California.

26. COMMUNITY COLLEGE DISTRICT BOUNDARIES

26.1. For locations outside the geographical boundaries of Allan Hancock College Joint Community College District, the COLLEGE will comply with the requirements of Title 5 of the California Code of Regulations, Sections 55300 et seq. or as amended, concerning approval by adjoining high school or community college districts and use of non-district facilities.

27. SEVERABILITY

27.1. This CCAP Agreement shall be considered severable, such that if any provision or part of the CCAP Agreement is ever held invalid under any law or ruling, that provision or part of the CCAP Agreement shall remain in force and effect to the extent allowed by law, and all other provisions or parts shall remain in full force and effect.

28. COUNTERPARTS

28.1. This CCAP Agreement may be executed by the PARTIES in separate counterparts, each of which when so executed and delivered shall be an original, but all such counterparts shall together constitute one and the same instrument.

IN WITNESS WHEREOF, the PARTIES hereto have caused this CCAP Agreement to be executed on the dates set forth below, to be effective as of the Effective Date.

ALLAN HANCOCK JOINT COMMUNITY
COLLEGE DISTRICT

ORCUTT UNION SCHOOL DISTRICT

By: _____
Associate Superintendent/Vice President of
Finance and Administration

By: _____
Superintendent

Date: _____

Date: _____

ALLAN HANCOCK JOINT COMMUNITY
COLLEGE DISTRICT BOARD MEETINGS

ORCUTT UNION SCHOOL DISTRICT
BOARD MEETINGS

Information Board Meeting Date:

Information Board Meeting Date:

Public Comment
and Approval Board Meeting Date:

Public Comment
and Approval Board Meeting Date:

APPENDIX A

ALLAN HANCOCK COLLEGE JOINT COMMUNITY COLLEGE DISTRICT

Agreement with INSTRUCTOR

This agreement is made and entered into this _____ [day] of _____ [month] ____ [year] by three parties: The Allan Hancock College Joint Community College District (hereinafter “COLLEGE”), the _____ [high school district] (hereinafter “SCHOOL DISTRICT”) and _____ [first name, last name], an employee of the SCHOOL DISTRICT (hereinafter “INSTRUCTOR”) who is being assigned to the COLLEGE on a part-time basis pursuant to Title 5, California Code of Regulations, section 58058(b).

WHEREAS, the SCHOOL DISTRICT has the experience, training, equipment and other resources, and staff necessary to provide instruction to COLLEGE students through the CCAP Agreement;

WHEREAS, Title 5, California Code of Regulations, section 58050, subdivision (a) provides authority for claiming apportionment;

NOW, THEREFORE, the three parties to this Agreement hereby agree as follows:

1. The SCHOOL DISTRICT’s INSTRUCTOR is an employee of the SCHOOL DISTRICT who shall meet “Minimum Qualifications” for the academic position of COLLEGE’s INSTRUCTOR as established by the COLLEGE and as determined by the COLLEGE.
2. The SCHOOL DISTRICT’s INSTRUCTOR is professionally and specially trained and competent to provide the supervisory and/or instructional services required by the COLLEGE.
3. The INSTRUCTOR will be an employee of the COLLEGE for purposes of the Attendance Accounting Standards (Ed. Code, § 58050). COLLEGE has the right to; 1) evaluate and terminate INSTRUCTOR; 2) evaluate the quality of instruction to ensure that it meets the needs of students; 3) evaluate the quality and rigor equal to the COLLEGE’S approved course outline of record and the accreditation requirements of COLLEGE. The COLLEGE will not provide INSTRUCTOR evaluation results to the SCHOOL DISTRICT.
4. The SCHOOL DISTRICT’s INSTRUCTOR shall at all times comply with the supervisory and/or instructional requirements outlined in Title 5, California Code of Regulations, section 58055, which require direct instruction by the SCHOOL DISTRICT’s INSTRUCTOR except in limited circumstances. The SCHOOL DISTRICT’s INSTRUCTOR’s responsibilities and duties as an employee of the COLLEGE shall include, but are not limited to, the following:
 - 4.1. Ensure that an instructional time of 50 minutes per class each day is expended in full compliance with the course objectives determined by the COLLEGE.
 - 4.2. Ensure the safety and well-being of students.
 - 4.3. Be in sufficient physical proximity and range of communication to provide immediate instructional supervision and control of all students in his/her classes.
 - 4.4. Attend periodic staff meetings with the COLLEGE.
 - 4.5. Regularly check and respond to communication from COLLEGE.
 - 4.6. Priority in class enrollment shall be given to students desiring to take the course for college credit towards a degree or certificate (Ed. Code § 76370). Ensure accurate and current daily student attendance records, accurate calculation of final student grades of

all students enrolled in the course for college credit, and the prompt submission of all data necessary for the calculation of FTES to the DISTRICT within 3 (three) calendar days of course completion (Ed. Code § 84500).

- 4.7. Ensure the effective use of instructional methods, technology, testing and remediation.
 - 4.8. Ensure that he/she does not have any other assigned duties during the instructional activity where multiple skill levels of students are being taught for which attendance is being claimed.
 - 4.9. Be familiar with and comply with all relevant COLLEGE policies, rules and regulations, including but not limited, to those related to student safety, grading, attendance, sexual harassment and discrimination.
 - 4.10. Provide support to SCHOOL DISTRICT students taking COLLEGE courses under CCAP agreement with COLLEGE admission and registration procedures.
5. The SCHOOL DISTRICT shall indemnify and hold harmless the COLLEGE and its authorized agents, officers, and employees against any and all claims and actions arising from the SCHOOL DISTRICT's INSTRUCTOR's or SCHOOL DISTRICT's negligent, reckless or intentional acts, errors or omissions and for any cost or expense incurred by the COLLEGE on account of any claim therefor.
 6. The COLLEGE shall provide no compensation to the SCHOOL DISTRICT's INSTRUCTOR for any services rendered pursuant to this Agreement, but compensation, as well as workers' compensation insurance, shall be the responsibility of the SCHOOL DISTRICT in accordance with its established and standard practices.
 7. This Agreement may be terminated at any time by the COLLEGE within the sole and exclusive discretion of the COLLEGE upon written notice to the SCHOOL DISTRICT and the SCHOOL DISTRICT's INSTRUCTOR. This Agreement may be terminated upon thirty (30) days' prior written notice to COLLEGE by either the SCHOOL DISTRICT or the SCHOOL DISTRICT's INSTRUCTOR within either's sole and exclusive discretion.

IN WITNESS WHEREOF, the parties hereto have executed this Agreement the day and year last written below.

INSTRUCTOR

ALLAN HANCOCK COLLEGE JOINT
COMMUNITY COLLEGE DISTRICT

Print

Print

Signature

Signature

APPENDIX B

Identification of CCAP Pathways for Course-Specific College and Career Pathway Opportunities

Pursuant to California Assembly Bill No. 288, the COLLEGE and SCHOOL DISTRICT enter into this partnership agreement to offer College and Career Pathways (CCAP) to high school students to expand dual enrollment opportunities to facilitate college and career readiness, particularly among students who may not already be college-bound or who are underrepresented in higher education.

The goal of the CCAP partnership is to offer seamless pathways from high school to community college to promote: 1) academic preparation for transfer to four-year colleges and universities; 2) completion of career and technical education programs for entry into the workforce; (3) improving high school graduation rates, and (4) helping high school pupils achieve college and career readiness.

The following pathways are included in the CCAP partnership agreement between the COLLEGE and SCHOOL DISTRICT:

Career and Technical Education:

1. This pathway includes COLLEGE courses in a Career and Technical education (“CTE”) pathway at the college level that apply to an Allan Hancock College degree or certificate in the pathway. This includes:
 - a. Naming of HIGH SCHOOL Pathway and Course Location in Sequence (Introductory, Concentrator, Capstone, or Practicum)
 - b. Naming of COLLEGE Pathway – Degree or Certificate
 - c. Identifying Career/Employment Outcomes associated with CTE Pathway
 - d. Identifying the course(s) in the Pathway to be offered under the CCAP Agreement.
2. Examples of CTE Technical Pathways include Automotive, Digital Art and Graphic Design, Culinary, Early Childhood Studies, Welding etc.

College and Career Readiness:

1. This pathway includes COLLEGE courses in career exploration and career development that prepare students in college and career planning. Successful completion of these courses will allow students to matriculate at college level in courses in a CTE pathway or General Education/California State University (“CSU”) Transfer pathway.
2. Course examples include: WEE (Work Experience); PD (Career Planning).

Preparation for Transfer:

1. California General Education Transfer Curriculum (Cal-GETC). This pathway includes COLLEGE courses which have been approved to meet the lower-division general education requirements at any CSU or University of California campus (i.e. Areas 1-6)

Improve High School Graduation Rates:

1. Student participation in college courses improves graduation rates of students who participate compared to peers who do not participate in college-level coursework.

APPENDIX C

CCAP Agreement Courses Approved for 2025 - 2026

HIGH SCHOOL DISTRICT:

Orcutt Union School District

HIGH SCHOOL SITE:

Orcutt Academy High School

PROJECTED NUMBER

1,072

OF STUDENTS TO BE SERVED:

TOTAL PROJECTED FTES:

209.5

CCAP Pathway	College Degree or Certificate	High School Pathway	CCAP Course Offerings		Number of Sections, High School period(s) & Times		Instructor Name & Employer of Record (AHC or HS)		Projected Number of Students	Projected FTES
			FALL	SPRING	FALL	SPRING	FALL	SPRING		
Career Technical Education	Admin of Justice - AS	Early College	AJ 101	AJ 105	1 section Zero Period 7:15 am - 8:20 am	1 section Zero Period 7:15 am - 8:20 am	TBD (AHC)	TBD (AHC)	30	6.18
Career Technical Education	Admin of Justice: Cyber Security - CA	Information & Technology	AJ 160	AJ 162	1 section 5th period 1:28 pm - 2:26 pm	1 section 5th period 1:28 pm - 2:26 pm	TBD (HS)	TBD (HS)	15	3.09
Career Technical Education	Early Childhood Education - AA-T	Early College	ECS 100	EDUC 130	2 sections 3rd, 4th periods 10:44 am -11:45 am 11:51 pm -12:49 pm	2 sections 3rd, 4th periods 10:44 am -11:45 am 11:51 pm -12:49 pm	Michael Shaw (HS)	Michael Shaw (HS)	50	13.71
Career Technical Education	Medical Assisting - CA	Health Science	-	MA 305	-	1 section 4th period 11:51 am - 12:49 pm	-	TBD (AHC)	20	3.43
Preparation for Transfer	AA-T Cal-GETC	Early College	ENGL C1000	ENGL 145	3 sections 2nd, 3rd, 4th periods 9:24 am - 10:32 am 10:44 am -11:45 am 11:51 pm -12:49 pm	3 sections 2nd, 3rd, 4th periods 9:24 am - 10:32 am 10:44 am -11:45 am 11:51 pm -12:49 pm	Graham Culbara (HS)	Graham Culbara (HS)	90	21.69

Preparation for Transfer	Liberal Arts – AA-T	Early College	Rooted in Narrative (HS)	ENGL C1001	high school course TBD	3 sections 2nd, 3rd, 4 th periods 9:24 am – 10:32 am 10:44 am – 11:45 am 11:51 pm – 12:49 pm	-	Jordan Willis (HS)	90	9.26
Preparation for Transfer	Liberal Arts – AA-T	Early College	HIST 101	HIST 102	3 sections 2nd, 3rd, 4 th periods 9:24 am – 10:32 am 10:44 am – 11:45 am 11:51 pm – 12:49 pm	Joel Mason (HS)	Joel Mason (HS)	90	18.52	
Preparation for Transfer	Liberal Arts – AA-T	Early College	HIST 107	HIST 108	3 sections 2nd, 3rd, 4 th periods 9:24 am – 10:32 am 10:44 am – 11:45 am 11:51 pm – 12:49 pm	Gregory Verch (HS)	Gregory Verch (HS)	90	18.52	
Preparation for Transfer	Liberal Arts – AA-T	Early College	Statistics (HS)	STAT C1000	high school course	2 sections 2nd, 4 th periods 9:24 am – 10:32 am 11:51 pm – 12:49 pm	Heather Penk (HS)	Heather Penk (HS)	50	8.57
Preparation for Transfer	Liberal Arts – AA-T	Early College	MATH 131	MATH 121	2 sections 2nd, 4 th periods 9:24 am – 10:32 am 11:51 pm – 12:49 pm	Joshua Mason (HS)	Joshua Mason (HS)	60	14.4	
Preparation for Transfer	Liberal Arts – AA-T	Early College	Spanish 3 (HS)	SPAN 102	high school course	1 section 1st period 8:30 am – 9:28 am	Heidi Miller (HS)	Heidi Miller (HS)	30	5.14
Preparation for Transfer	Liberal Arts – AA-T	Early College	Spanish 2 (HS)	SPAN 101	high school course	4 sections 2nd, 3rd, 4th, 5th periods 9:24 am – 10:32 am 10:44 am – 11:45 am 11:51 pm – 12:49 pm 1:28 pm – 2:26 pm	Heidi Miller (HS)	Heidi Miller (HS)	115	19.71
Preparation for Transfer	AS-T Cal-GETC	Early College	MATH 181	MATH 182	1 section 2 nd period 9:24 am – 10:32 am	John Dell'Armo (HS)	John Dell'Armo (HS)	22	7.54	
Preparation for Transfer	Liberal Arts – AA-T	Early College	HUSV 110	SOC 101	1 section After School 3:30 pm – 5:00 pm	TBD (AHC)	TBD (AHC)	20	4.12	
Preparation for Transfer	Liberal Arts – AA-T	Early College Cadre 29	ART 101	AJ 105	1 section Zero Period 7:15 am – 8:20 am	TBD (AHC)	TBD (AHC)	30	6.18	
Preparation for Transfer	Liberal Arts – AA-T	Early College Cadre 28	MUS 100	DRMA 103	1 section Zero Period 7:15 am – 8:20 am	TBD (AHC)	TBD (AHC)	30	6.18	
Preparation for Transfer	Liberal Arts – AA-T	Early College Cadre 27	GEOG 101	-	1 section Zero Period 7:15 am – 8:20 am	TBD (AHC)	TBD (AHC)	30	3.09	

Preparation for Transfer	Liberal Arts – AA-T	Early College Cadre 26	ES 120	-	1 section Zero Period 7:15 am - 8:20 am	-	TBD (AHC)	-	30	3.09
College & Career Readiness	AA GE	Freshman Success	PROD 301	EMS 102	1 section 1st period 8:30 – 9:28 am	1 section 1st period 8:30 – 9:28 am	Carrie O’Keefe (HS)	Roy Dugger (AHC)	30	6.18
College & Career Readiness	AA GE	Freshman Success	EMS 102	PROD 301	1 section 1st period 8:30 – 9:28 am	1 section 1st period 8:30 – 9:28 am	Roy Dugger (AHC)	Carrie O’Keefe (HS)	30	6.18
College & Career Readiness	AA GE	Freshman Success	PD 101	PROD 301	2 sections 2nd, 3rd periods 9:24 am – 10:32 am 10:44 am – 11:45 am	2 sections 2nd, 3rd periods 9:24 am – 10:32 am 10:44 am – 11:45 am	TBD (AHC)	Carrie O’Keefe (HS)	60	12.36
College & Career Readiness	AA GE	Freshman Success	PROD 301	PD 101	2 sections 2nd, 3rd periods 9:24 am – 10:32 am 10:44 am – 11:45 am	2 sections 2nd, 3rd periods 9:24 am – 10:32 am 10:44 am – 11:45 am	Carrie O’Keefe (HS)	TBD (AHC)	60	12.36

1. **Required:** Describe the criteria used to assess the ability of pupils to benefit from the course(s) offered:

In consultation with their SCHOOL DISTRICT counselors, students self-select a pathway based on their academic readiness and alignment of course content to students’ educational and career goals. SCHOOL DISTRICT and COLLEGE faculty identified CCAP courses using the following criteria:

- Alignment with HIGH SCHOOL pathways and COLLEGE programs of study.
- Potential for course completion to accelerate students’ time to completion of postsecondary degree or certificate.
- Potential to earn a Certificate of Training and be eligible to enter the workforce in their selected career technical pathway.
- Potential to work toward completion of an associate degree or an associate degree for transfer.

2. **MINIMUM QUALIFICATIONS FOR INSTRUCTION:** All instructors teaching CCAP Agreement Courses must meet the minimum qualifications for instruction in a California community college as set forth in Title 5 of the California Code of Regulations, sections 53410 and 58060 or as amended. The minimum qualifications for instruction are:

Course Name & Number	Minimum Qualifications For Instructors
AJ 101 AJ 105 AJ 160 AJ 162	<ul style="list-style-type: none"> • Any bachelor’s degree or higher and two years of professional experience • OR any associate degree and six years of professional experience. <p>NOTE: Professional experience is required when the application possesses a master’s degree. The professional experience required must be directly related to the teaching assignment.</p>
ART 101	<ul style="list-style-type: none"> • Master’s degree in fine arts, art, or art history • OR bachelor’s degree in any of the above AND master’s degree in humanities • OR the equivalent <p>NOTE: “master’s degree in fine arts” as used here refers to any master’s degree in the subject matter of fine arts, which is defined to include visual studio arts such as drawing, painting, sculpture, printmaking, ceramics, textiles, and metal and jewelry art, and also art education and art therapy. It does not refer to the “Master of Fine Arts” (MFA) degree when that degree is based on specialization in performing arts or dance, film, video, photography, creative writing or other nonplastic arts.</p>
DRMA 103	<ul style="list-style-type: none"> • Master’s degree or Master’s degree of Fine Arts in drama/theater arts/performance • OR bachelor’s degree or bachelor’s degree of Fine Arts in drama/theater arts/performance AND master’s degree in comparative literature, English, communication studies, speech, literature or humanities • OR the equivalent
ECS 100	<ul style="list-style-type: none"> • Master’s degree in child development, early childhood education, human development, home economics/family and consumer studies with a specialization in child development/early childhood education or educational psychology with a specialization in child development/early childhood education • OR bachelor’s degree in any of the above AND master’s in social work, educational supervision, elementary education, special education, psychology, bilingual/bicultural education, life management/home economics, family life studies or family and consumer studies • OR the equivalent

ES 120	<ul style="list-style-type: none"> • Master's degree in African American Studies, Black Studies, Africana Studies, Latino Studies, La Raza Studies, Chicana/o Studies, Asian American Studies, Native American Studies, or American Indian Studies • OR master's degree in ethnic studies • OR the equivalent
EDUC 130	<ul style="list-style-type: none"> • Master's degree in education • OR the equivalent
EMS 102	<ul style="list-style-type: none"> • Any bachelor's degree or higher and two years of professional experience • OR any associate degree and six years of professional experience. <p>NOTE: Professional experience is required when the application possesses a master's degree. The professional experience required must be directly related to the teaching assignment.</p>
ENGL C1000 ENGL C1001 ENGL 145	<ul style="list-style-type: none"> • Master's degree in English, literature, comparative literature, or composition • OR bachelor's degree in any of the above AND master's degree in linguistics, TESL, speech, education with a specialization in reading, creative writing or journalism • OR the equivalent
GEOG 101	<ul style="list-style-type: none"> • Master's degree in geography • OR bachelor's degree in geography AND master's degree in geology, history, meteorology or oceanography • OR the equivalent
HIST 101 HIST 102 HIST 107 HIST 108	<ul style="list-style-type: none"> • Master's degree in history • OR bachelor's degree in history AND master's degree in political science, humanities, geography, area studies, women's studies, social science or ethnic studies • OR the equivalent
HUSV 110	<ul style="list-style-type: none"> • Any bachelor's degree or higher and two years of professional experience in Addiction Paraprofessional Training • OR any associate degree and six years of professional experience. <p>NOTE: Professional experience is required when the application possesses a master's degree. The professional experience required must be directly related to the teaching assignment.</p> <ul style="list-style-type: none"> • Master's degree in counseling, rehabilitation counseling, clinical psychology, counseling psychology, guidance counseling, educational counseling, social work, career development,

	<p>marriage and family therapy, or marriage, family and child counseling</p> <ul style="list-style-type: none"> • NOTE: A bachelor's degree in one of the listed degrees and a license as a Marriage and Family Therapist (MFT) is an alternative qualification for this discipline • OR master's degree in education • OR the equivalent
MA 305	<ul style="list-style-type: none"> • Any bachelor's degree or higher and two years of professional experience • OR any associate degree and six years of professional experience. <p>NOTE: Professional experience is required when the application possesses a master's degree. The professional experience required must be directly related to the teaching assignment.</p>
MATH 121 MATH 123 MATH 131 MATH 181 MATH 182	<ul style="list-style-type: none"> • Master's degree in mathematics or applied mathematics • OR bachelor's degree in either of the above AND master's degree in statistics, physics or mathematics education • OR the equivalent
MUS 100	<ul style="list-style-type: none"> • Master's degree in music • OR bachelor's degree in music AND master's degree in humanities • OR the equivalent
PD 101	<ul style="list-style-type: none"> • Master's degree in counseling, rehabilitation counseling, clinical psychology, counseling psychology, guidance counseling, educational counseling, social work, career development, marriage and family therapy, or marriage, family and child counseling • NOTE: A bachelor's degree in one of the listed degrees and a license as a Marriage and Family Therapist (MFT) is an alternative qualification for this discipline • OR master's degree in education • OR the equivalent
PROD 301	<ul style="list-style-type: none"> • Master's degree in counseling, rehabilitation counseling, clinical psychology, counseling psychology, guidance counseling, educational counseling, social work, career development, marriage and family therapy, or marriage, family, and child counseling • OR the equivalent <p>NOTE: A bachelor's degree in one of the listed degrees and a license as a Marriage and Family Therapist (MFT) is an alternative qualification for this discipline</p> <ul style="list-style-type: none"> • OR master's degree in education

	<ul style="list-style-type: none"> OR any bachelor's degree or higher and two years of professional experience in Office Technologies OR any associate degree and six years of professional experience in Office Technologies. <p>NOTE: Professional experience is required when the application possesses a master's degree. The professional experience required must be directly related to the teaching assignment.</p>
PSY 101	<ul style="list-style-type: none"> Master's degree in psychology OR bachelor's degree in psychology AND master's degree in counseling, sociology, statistics, neuroscience or social work OR the equivalent
SOC 101	<ul style="list-style-type: none"> Master's degree in sociology OR bachelor's degree in sociology AND master's degree in anthropology, any ethnic studies, social work, or psychology OR the equivalent
SPAN 101 SPAN 102	<ul style="list-style-type: none"> Master's degree in Spanish OR bachelor's degree in Spanish AND master's degree in another language or linguistics OR the equivalent

- BOOKS AND INSTRUCTIONAL MATERIALS:** The total cost of books and instructional materials for SCHOOL DISTRICT students participating in CCAP course as part of this CCAP Agreement will be borne by SCHOOL DISTRICT. Current pricing and textbook availability are published on the COLLEGE bookstore website each semester.
- JOINT FACILITIES USE PROTOCOLS:** COLLEGE and SCHOOL DISTRICT shall adhere to the terms and protocols outlined in Section 19, Facilities, of the CCAP Agreement. SCHOOL DISTRICT, shall extend access and use of the following SCHOOL DISTRICT facilities:

BUILDING NAME & ADDRESS	CLASSROOMS	DAYS	HOURS
Orcutt Academy High School (OAHs) 610 Pinal Avenue Orcutt, CA 93455	K-2	Monday – Friday	7:30 am – 5:00 pm

Orcutt Academy High School	1 through 33	Monday – Friday	7:30 am – 5:00 pm
610 Pinal Avenue Orcutt, CA 93455			

ALLAN HANCOCK JOINT COMMUNITY COLLEGE DISTRICT ORCUTT ACADEMY HIGH SCHOOL

By: _____
Vice-President, Academic Affairs

By: 
Principal

Date: _____

Date: 5/28/2025
By: 
Head Counselor

Date: 5/28/25

APPENDIX D Registration Timeline 2025 - 2026

2025-2026 Week Ranges	Process	Timeline	Type
Week 1: July 1, 2025 - July 7, 2025			
Week 2: July 8, 2025 - July 14, 2025			
Week 3: July 15, 2025 - July 21, 2025			
Week 4: July 22, 2025 - July 28, 2025			
Week 5: July 29, 2025 - August 4, 2025	Ideal	CRNs available for DualEnroll & we see bulk of forms (Would like Aug 1 deadline for CRNs)	CCAP
Week 6: August 5, 2025 - August 11, 2025	Ideal	(NonCCAP) Late Add influx, Appeal Delays, Registration Processing Delays	
Week 6: August 5, 2025 - August 11, 2025	Ideal	Firm Deadline for NonCCAP Petitions (Fall 2025)	NonCCAP
Week 6: August 5, 2025 - August 11, 2025	Ideal	(NonCCAP) Bulk of Petitions come in around this time through first day of AHC classes	NonCCAP
Week 7: August 12, 2025 - August 18, 2025		Start of Fall Term for HS Partners (Average)	
Week 8: August 19, 2025 - August 25, 2025		Start of Fall Term for AHC	
Week 8: August 19, 2025 - August 25, 2025	Actual	(NonCCAP) We accepted petitions for up until the start of classes (extended)	NonCCAP
Week 8: August 19, 2025 - August 25, 2025		Winter app opens	
Week 9: August 26, 2025 - September 1, 2025	Actual	Influx of Fall Petitions Timeframe	Both
Week 9: August 26, 2025 - September 1, 2025	Actual	(NonCCAP) Late Add influx, Appeal Delays, Registration Processing Delays	NonCCAP
Week 10: September 2, 2025 - September 8, 2025	Actual	CRNs available in DualEnroll & we see beginning of bulk of forms	CCAP
Week 10: September 2, 2025 - September 8, 2025	Ideal	Spring app opens for CCAP students	CCAP
Week 11: September 9, 2025 - September 15, 2025			
Week 12: September 16, 2025 - September 22, 2025			
Week 14: September 30, 2025 - October 6, 2025	Ideal	CCAP CRNs available (Spring 2026)	CCAP
Week 14: September 30, 2025 - October 6, 2025	Ideal	CCAP Registration Begins (Spring 2026)	CCAP
Week 14: September 30, 2025 - October 6, 2025		Spring app opens	
Week 14: September 30, 2025 - October 6, 2025	Actual	Deadline for NonCCAP Petitions (Fall 2025 Term 2)	NonCCAP
Week 15: October 7, 2025 - October 13, 2025			
Week 16: October 14, 2025 - October 20, 2025	Actual	AHC accepting NonCCAP petitions (Winter/Spring 2026)	NonCCAP
Week 16: October 14, 2025 - October 20, 2025		Class Search opens	
Week 17: October 21, 2025 - October 27, 2025			
Week 18: October 28, 2025 - November 3, 2025	Ideal	Fall processing complete for CCAP	CCAP
Week 19: November 4, 2025 - November 10, 2025	Actual	CRN available for CCAP for spring	CCAP
Week 20: November 11, 2025 - November 17, 2025	Actual	NonCCAP Registration Begins (Winter/Spring 2026)	NonCCAP
Week 20: November 11, 2025 - November 17, 2025	Actual	CCAP Registration Begins (Early Spring 2026)	CCAP
Week 21: November 18, 2025 - November 24, 2025			
Week 22: November 25, 2025 - December 1, 2025			
Week 23: December 2, 2025 - December 8, 2025	Ideal	Influx of CN Spring Petitions Timeframe	NonCCAP

FALL

SPRING

APPENDIX D Registration Timeline 2025 - 2026

Week 23: December 2, 2025 - December 8, 2025	Ideal	Deadline for NonCCAP Petitions (Winter 2026)	CCAP
Week 24: December 9, 2025 - December 15, 2025	Ideal	Bulk of CCAP registrations submitted for Spring	CCAP
Week 25: December 16, 2025 - December 22, 2024	Actual	Processing completed for Fall CCAP	CCAP
Week 25: December 16, 2025 - December 22, 2025	Actual	Start of Winter Term for AHC	
Week 26: December 23, 2025 - December 29, 2025			
Week 27: December 30, 2025 - January 5, 2026			
Week 28: January 6, 2026 - January 12, 2026	Actual	Deadline for NonCCAP Petitions (Spring 2026)	
Week 29: January 13, 2026 - January 19, 2026	Actual	Start of Spring Term for HS Partners (Average)	Both
Week 29: January 13, 2026 - January 19, 2026	Actual	Influx of CN petitions	Both
Week 30: January 20, 2026 - January 26, 2026	Actual	Start of Spring Term for AHC	
Week 31: January 27, 2026 - February 2, 2026	Actual		
Week 32: February 3, 2026 - February 9, 2026	Actual	We see bulk of our CCAP forms being turned in	CCAP
Week 33: February 10, 2026 - February 16, 2026	Actual	We see bulk of our CCAP forms being turned in	CCAP
Week 34: February 17, 2026 - February 23, 2026		CCAP Sections Identify and Created - Alicia to meet with High Schools (summer/fall 2026)	
Week 35: February 24, 2026 - March 2, 2026			
Week 36: March 3, 2026 - March 9, 2026			
Week 37: March 10, 2026 - March 16, 2026			
Week 38: March 17, 2026 - March 23, 2026			
Week 39: March 24, 2026 - March 30, 2026		CCAP Sections CRNs Complete (summer/fall 2026)	
Week 40: March 31, 2026 - April 6, 2026			
Week 41: April 7, 2026 - April 13, 2026		AHC accepting NonCCAP petitions (summer/fall 2026)	
Week 41: April 7, 2026 - April 13, 2026	Actual	Summer/Fall Class Search Opens	
Week 42: April 14, 2026 - April 20, 2026			
Week 42: April 14, 2026 - April 20, 2026		Priority Reg	
Week 43: April 21, 2026 - April 27, 2026	Ideal	Spring processing complete for CCAP	CCAP
Week 44: April 28, 2026 - May 4, 2026			
Week 45: May 5, 2026 - May 11, 2026	Ideal	<i>NonCCAP Registration Begins (Summer/Fall 2026)</i>	
Week 46: May 12, 2026 - May 18, 2026	Actual	Deadline for NonCCAP Petitions (Spring Term 2 2026)	
Week 47: May 19, 2026 - May 25, 2026	Actual	Spring processing complete for CCAP	
Week 48: May 26, 2026 - June 1, 2026			
Week 49: June 2, 2026 - June 8, 2026	Ideal	Influx of Fall Petitions Timeframe	NonCCAP
Week 50: June 9, 2026 - June 15, 2026	Actual	Start of Summer Term for AHC	
Week 51: June 16, 2026 - June 22, 2026			
Week 52: June 23, 2026 - June 29, 2026			

SPRING

FALL

**COLLEGE AND CAREER ACCESS PATHWAYS (CCAP)
PARTNERSHIP AGREEMENT
BETWEEN
THE ALLAN HANCOCK JOINT COMMUNITY COLLEGE DISTRICT
AND
SANTA MARIA JOINT UNION HIGH SCHOOL DISTRICT**

This College and Career Access Pathway Partnership Agreement (“CCAP Agreement”) is between the Allan Hancock Joint Community College District (“COLLEGE”) and Santa Maria Joint Union High School District (“SCHOOL DISTRICT”). COLLEGE and SCHOOL DISTRICT will collectively be referred to as “PARTIES” or individually as “PARTY”.

RECITALS

WHEREAS, COLLEGE is a community college district whose mission includes providing educational programs and services that are responsive to the needs of the students and communities within the community college services area; and

WHEREAS, SCHOOL DISTRICT is a public school district located within the regional service area of the COLLEGE unless otherwise specified and agreed to as stated in AB 288, Sec. 2, Education Code section 76004, subdivision (e); and

WHEREAS, a high school (“HIGH SCHOOL”) “includes a community school, continuation high school, juvenile court school, or adult education program offering courses for high school diplomas or high school equivalency certificates” as stated in Education Code section 76004, subdivision (a)(2); and

WHEREAS, the PARTIES desire to enter into this CCAP Agreement for the purpose of offering or expanding dual enrollment opportunities, consistent with the provisions of the Education Code, for high school students “who may not already be college bound or who are underrepresented in higher education with the goal of developing seamless pathways from high school to community college for career technical education or preparation for transfer, improving high school graduation rates, and helping high school pupils achieve college and career readiness,” (Ed. Code, § 76004, subdivision (a)); and

WHEREAS, instruction will comply with the student selection standards, curriculum guidelines, recommendations and procedures promulgated by applicable law, the California Community College Chancellor’s Office and the COLLEGE; and

WHEREAS, the PARTIES desire to enter this CCAP, which sets forth their mutual rights and responsibilities and governs their relationship; and

WHEREAS, the PARTIES intend for COLLEGE to report full-time equivalent students (“FTES”) and obtain state apportionment for the subject courses given through this CCAP Agreement in

accordance with California Education Code, section 76004 and the appropriate portions of Title 5 of the California Code of Regulations; and

WHEREAS, participation in the CCAP Agreement is consistent with the core mission of California Community Colleges pursuant to Education Code section 66010.4, and that pupils participating in a CCAP partnership will not lead to enrollment displacement of otherwise eligible adults in the community college (Ed. Code, § 76004, subdivision (k)(2));

NOW, THEREFORE, PARTIES mutually agree as follows:

1. TERM OF AGREEMENT

1.1. **Effective Date and Duration.** The term of this CCAP Agreement shall be effective on **July 1, 2025**, and continue in effect until **June 30, 2026**, or until duly modified or terminated by the PARTIES in accordance with Section 1.2 of this CCAP Agreement.

1.2. Early Termination.

- a. This agreement may be terminated by either PARTY without cause or for any reason upon giving at least sixty (60) days prior written notice to the other PARTY. Any students currently enrolled in COLLEGE courses under this CCAP Agreement shall be allowed to complete those courses prior to the termination of this CCAP Agreement.
- b. This CCAP Agreement may be terminated by either PARTY with cause if another PARTY fails to comply with the insurance or indemnification requirements or otherwise commits a material breach. Termination will be effective no sooner than 15 calendar days after a written demand to cure is provided and the PARTY fails to cure. This remedy is in addition to any other remedy which may be provided for by law.

1.3. **The CCAP Agreement Appendix.** This CCAP Agreement outlines the terms of the Agreement.

- a. The CCAP Agreement Appendix shall specify CCAP Agreement Courses as well as additional details regarding, but not be limited to, the total number of high school students to be served and the total number of full-time equivalent students (“FTES”) projected to be claimed by the community college district for those students; the scope, nature, time, location, and listing of community college courses to be offered; and criteria to assess the ability of pupils to benefit from those courses:

Appendix A: Agreement with Instructor.

Appendix B: Identification of CCAP Pathways for Course-Specific College and Career Pathway Opportunities.

Appendix C: CCAP Agreement Courses Approved for [academic year].

Appendix D: Dual Enrollment Registration Timeline

- b. The CCAP Agreement Appendix C shall be reviewed and approved annually by both PARTIES by a duly adopted written amendment to this Agreement.

1.4. **Points of contact and Educational Administrators** are as follows:

COLLEGE:	Thomas Lamica , dean, academic affairs
SCHOOL DISTRICT:	Dr. Krista Herrera , assistant superintendent, curriculum and instruction
HIGH SCHOOL SITES:	Elizabeth Cortez , assistant principal, Ernest Righetti High School Mandy McDonald , college & career center specialist, Ernest Righetti High School Kevin Ilac , assistant principal, Pioneer Valley High School Melani Mederos , college & career center specialist, Pioneer Valley High School Jules Manfreda , assistant principal, Santa Maria High School TBD , Mark Richardson CTE Center and AG Farm

(Ed. Code, § 76004, subdivision (c)(2))

1.5. A copy of the COLLEGE and SCHOOL DISTRICT CCAP Agreement shall be filed with the office of the Chancellor of the California Community Colleges and with the California Department of Education before the start of the CCAP partnership. (Ed. Code, § 76004, subdivision (c)(3).)

1.6. COLLEGE and SCHOOL DISTRICT shall present this CCAP agreement at an open public meeting of their respective governing boards, allowing for public comments prior to consideration for approval or disapproval of this CCAP agreement. (Ed. Code, § 76004, subdivision (b)(2).)

2. DEFINITIONS

2.1. **CCAP Agreement Courses.** CCAP Agreement Courses offered as part of this CCAP Agreement shall be community college courses acceptable towards a career technical education credential or certificate, preparation for transfer, or appropriate to improve high school graduation rates or help high school pupils achieve college and career readiness. (Ed. Code § 76004, subdivision (a).) All community college courses offered at the SCHOOL DISTRICT have been approved in accordance with the policies and guidelines of COLLEGE and applicable law. Courses offered at the COLLEGE that are open to the public for enrollment fall outside of this CCAP agreement and are subject to all conditions and rules of the COLLEGE.

2.2. **Pupil or Student Fees.** Pupil or Student is defined as a resident or nonresident student attending HIGH SCHOOL in California. SCHOOL DISTRICT pupils enrolled in a course offered through this CCAP Agreement shall not be assessed any fee that is prohibited by

Education Code section 49011 (Ed. Code § 76004, subdivision (f)), including a fee charged to a student or a student's parent or guardian as a condition for course registration or for textbooks, supplies, materials and equipment needed to participate in the course. Students who are enrolled in a combination of CCAP and regular credit college courses will be subject to all fees assessed for the regular credit college enrollment for the regular credit college courses.

3. STUDENT ELIGIBILITY, SELECTION AND ENROLLMENT, ADMISSION, REGISTRATION, MINIMUM SCHOOL DAY

- 3.1. **Student Eligibility.** Students who "may not already be college bound or who are underrepresented in higher education, with the goal of developing seamless pathways from high school to community college for career technical education or preparation for transfer, improving high school graduation rates, or helping high school pupils to achieve college and career readiness" and "underachieving students, those from groups underrepresented in postsecondary education, those who are seeking advanced studies while in high school, and those seeking a career technical education credential or certificate" are eligible to participate in CCAP courses hosted at a SCHOOL DISTRICT site. (Education Code § 76004, subdivision (a); Assembly Bill 288 (2015) Section I, subdivision (d))
- 3.2. **Student Selection and Enrollment.** Enrollment shall be open to all eligible students as part of the CCAP Agreement who have been admitted to the COLLEGE and who meet all applicable prerequisites. Student selection criteria will be further specified in the CCAP Agreement Appendix C. Applicable prerequisite courses, training, or experience and standards required as preparation for courses offered through the CCAP Agreement will be determined by COLLEGE and shall be in compliance with applicable law and COLLEGE standards and policies.
- 3.3. **College Admission and Registration.** Procedures for students participating in the CCAP Agreement shall be governed by the COLLEGE and shall be in compliance with the admissions and registration guidelines outlined in applicable law and COLLEGE policy.
- 3.4. **Records of Student Attendance.** All records of student attendance and achievement shall be submitted to COLLEGE periodically using the COLLEGE student information system or upon demand and shall be maintained by COLLEGE.
- 3.5. **Priority Enrollment.** Students enrolling in a CCAP course will have priority enrollment by virtue of their status. High school students enrolling in non-CCAP college courses will not be eligible for priority registration.
- 3.6. **Physical Education Courses.** As part of a CCAP Agreement, a participating community college district shall not provide physical education course opportunities to high school students or any other course opportunities that do not assist in the attainment of the goals associated with career technical education or preparation for transfer, improving high school graduation rates, or helping high school students achieve career and college readiness. (Ed. Code § 76004, subdivision (d)).
- 3.7. **Maximum Units.** Students participating under a CCAP Agreement may enroll in up to a maximum of 15 units per term, without exception, if all the following conditions specified in Assembly Bill 288, Sec. 2 (p)(1)(2)(3) are satisfied:
- a. The units constitute no more than four community college courses per term.

- b. The units are part of an academic program that is part of a CCAP partnership agreement established pursuant to this article.
- c. The units are part of an academic program that is designed to award students both a high school diploma and an associate degree or a certificate or credential.

3.8. **Minimum School Day.** The SCHOOL DISTRICT shall certify that it shall teach SCHOOL DISTRICT students participating as part of a CCAP Agreement no less than the number of instructional minutes required to complete a minimum school day pursuant to Education Code sections 46141 and 46142.

3.9. **Enrollment Restriction.** COLLEGE reserves the right to block students from enrolling in any courses for students who incur an unpaid debt for a non-CCAP class at the college. COLLEGE agrees to remove the enrollment block when debt is paid in full.

4. COLLEGE APPLICATION PROCEDURE

4.1. The COLLEGE will be responsible for processing student applications.

4.2. The COLLEGE will provide the necessary admission and registration forms and procedures, and both COLLEGE and SCHOOL DISTRICT will jointly ensure that each applicant accepted has met all the enrollment requirements.

4.3. The SCHOOL DISTRICT agrees to assist COLLEGE in the admission and registration of SCHOOL DISTRICT students as may be necessary and requested by COLLEGE.

5. PARTICIPATING STUDENTS

5.1. The total cost of books and instructional materials for SCHOOL DISTRICT students who enroll in a COLLEGE course offered as part of this CCAP Agreement will be borne by SCHOOL DISTRICT.

5.2. Both COLLEGE and SCHOOL DISTRICT will ensure that ancillary and support services are accessible to students (e.g., Tutoring.)

5.3. A student taking courses under this CCAP Agreement with an Individual Education Plan or 504 Plan with the SCHOOL DISTRICT may request accommodation for his or her disability to participate in the educational programs and activities required by the COURSE and COLLEGE. Accommodation required by state law or SCHOOL DISTRICT policy will be provided through SCHOOL DISTRICT in consultation with the COLLEGE Learning Assistance Program (LAP) Office. Students requesting services by the LAP office will need to follow the standard process for requesting accommodations.

6. CCAP AGREEMENT COURSES

6.1. The COLLEGE may limit enrollment in a community college course solely to eligible high school students if the course is offered at a high school campus during the regular school day and the community college course is offered pursuant to this CCAP Agreement.

6.2. The COLLEGE is responsible for all courses and educational programs offered as part of CCAP Agreement .

6.3. The scope, nature, time, location, and listing of courses offered by a COLLEGE shall be determined by COLLEGE in consultation with the SCHOOL DISTRICT and with the

- approval of the COLLEGE and will be recorded in the Appendix C to this CCAP Agreement.
- 6.4. Courses offered as part of a CCAP Agreement shall be jointly selected and approved by COLLEGE and SCHOOL DISTRICT.
 - 6.5. Courses offered as part of this CCAP Agreement shall have a minimum enrollment of fifteen (15) students.
 - 6.6. The SCHOOL DISTRICT confirms that each approved CCAP course is held for no less than 50 minutes each class day in full compliance with the course outcomes determined by the COLLEGE.
 - 6.7. Degree and certificate programs that are included in the CCAP agreement must have been approved by the California Community College Chancellor's Office and courses offered at the SCHOOL DISTRICT shall adhere to the official course outline of record and the student learning outcomes established by the associated academic department within the COLLEGE, approved by the COLLEGE Academic Policy & Planning (AP&P) Committee and submitted to the Chancellor's Office. Course outlines will be provided to the SCHOOL DISTRICT.
 - 6.8. Courses must meet the number of hours sufficient to meet the stated performance objectives as outlined in the course outlines provided to the SCHOOL DISTRICT on a semester basis.
 - 6.9. Courses offered at the SCHOOL DISTRICT as part of this CCAP Agreement shall be of the same quality and rigor as those offered on the COLLEGE campus and shall be in compliance with COLLEGE academic standards.
 - 6.10. Courses offered as part of this CCAP Agreement will comply with all applicable regulations, policies, procedures, prerequisites, and standards applicable to the COLLEGE as well as any corresponding policies, practices, and requirements of the SCHOOL DISTRICT. In the event of a conflict between the COLLEGE course related regulations, policies, procedures, prerequisites and standards and SCHOOL DISTRICT policies, practices and requirements, the COLLEGE regulations, policies, procedures, prerequisites, and standards, shall prevail.
 - 6.11. A student's withdrawal prior to completion of a course offered as part of this CCAP Agreement shall be in accordance with COLLEGE guidelines, policies, pertinent statutes and regulations.
 - 6.12. Supervision and evaluation of students enrolled in courses offered as part of this CCAP Agreement shall be in accordance with COLLEGE guidelines, policies, pertinent statutes and regulations.
 - 6.13. COLLEGE has the sole right to control and direct the instructional activities for all CCAP Agreement courses and all instructors, including those who are SCHOOL DISTRICT employees.
 - 6.14. This CCAP Agreement certifies that any remedial course taught by community college faculty at a partnering high school campus shall be offered only to high school students who do not meet their grade level standard in math, English, or both on an interim assessment in grade 10 or 11, as determined by the partnering SCHOOL DISTRICT, and shall involve collaborative effort between the SCHOOL DISTRICT and the COLLEGE faculty to deliver an innovative remediation course as an intervention in the student's junior or senior year to ensure the student is prepared for college-level work upon graduation.
 - 6.15. CCAP Agreement Courses outlined in Appendix C shall be updated annually and

approved before the start of each academic year.

7. INSTRUCTORS

- 7.1. All instructors teaching COLLEGE courses offered as part of this CCAP Agreement must meet the minimum qualifications for instruction in a California community college as set forth in Title 5 California Code of Regulations, Sections 53410 and 58060 or as amended.
- 7.2. The CCAP Agreement Appendix C shall specify which participating SCHOOL DISTRICT or COLLEGE will be the employer of record for purposes of assignment monitoring and reporting to the county office of education.
- 7.3. This CCAP Agreement specifies that the SCHOOL DISTRICT will assume reporting responsibilities pursuant to applicable federal teacher quality mandates.
- 7.4. Instructors who teach COLLEGE courses offered as part of this CCAP Agreement must provide the supervision and control reasonably necessary for the protection of the health and safety of students and may not have any other assigned duty during the instructional activity.
- 7.5. Instructors who teach COLLEGE courses shall comply with the fingerprinting requirements set forth in Education Code section 45125 or as amended and the tuberculosis testing and risk assessment requirements of California Health and Safety Code section 121525 or as amended. In addition to any other prohibition or provision, no person who has been convicted of a violent or serious felony shall be eligible to teach any courses offered as part of this CCAP Agreement or otherwise provide services on a SCHOOL DISTRICT site. SCHOOL DISTRICT shall immediately notify COLLEGE if an instructor is charged with an offense prohibited by Education Code sections 44010 or 44011.
- 7.6. Prior to teaching, faculty provided by the SCHOOL DISTRICT shall participate in required discipline-specific training and orientation from COLLEGE regarding, but not limited to, course curriculum, assessment criteria, pedagogy, course philosophy, testing and grading procedures record keeping, and other instructional responsibilities. Such training shall be approved and provided by the COLLEGE.
- 7.7. Prior to teaching, instructors provided by the COLLEGE may receive training and orientation from SCHOOL DISTRICT regarding, but not limited to, SCHOOL DISTRICT policies, practices, and requirements. Such training may be approved and provided by the SCHOOL DISTRICT.
- 7.8. Faculty provided by the SCHOOL DISTRICT are eligible to participate in professional development activities sponsored by the COLLEGE as required by the terms and condition of the contract and shall be encouraged to participate in ongoing collegial interaction to include, but not limited to, addressing course content, course delivery, assessment, evaluation, and/or research and development in the field.
- 7.9. The COLLEGE shall evaluate faculty performance for the college courses using the adopted evaluation of process and standards for faculty of the COLLEGE, subject to the approval of COLLEGE.
- 7.10. The COLLEGE and SCHOOL DISTRICT will work collaboratively to identify instructors from SCHOOL DISTRICT who may meet minimum qualification requirements or local equivalency standards to teach a COLLEGE course and encourage them to apply for

consideration. Instructors will be required to go through the COLLEGE screening process for possible selection and assignment to the course.

- 7.11. The SCHOOL DISTRICT teachers approved to teach COLLEGE courses remain employees of the SCHOOL DISTRICT, subject to the authority of the SCHOOL DISTRICT, but will also be subject to the authority of COLLEGE specifically with regard to their duties as COLLEGE instructors, pursuant to the terms of Appendix A.
- 7.12. The COLLEGE shall determine the number of instructors, the ratio of instructors to students, and the subject areas of instruction.
- 7.13. Faculty provided by the SCHOOL DISTRICT who do not comply with the policies, regulations, standards, and expectations of the COLLEGE shall be ineligible to teach college courses under this CCAP Agreement.
- 7.14. SCHOOL DISTRICT teachers approved to teach CCAP Courses under this CCAP Agreement must submit grades to both the COLLEGE and SCHOOL DISTRICT using the COLLEGE student information system by the established timeline (Appendix D).
- 7.15. SCHOOL DISTRICT teachers approved by the COLLEGE shall sign an Agreement with the Instructor (Appendix A) prior to the start of each academic year.
- 7.16. SCHOOL DISTRICT teachers approved by the COLLEGE shall provide support to high school students taking COLLEGE courses under CCAP agreement with COLLEGE admission and registration procedures.

8. ASSESSMENT OF LEARNING AND CONDUCT

- 8.1. Students enrolled in COLLEGE courses offered as part of this CCAP Agreement at the SCHOOL DISTRICT shall be held to the same standards of achievement as students in courses taught on the COLLEGE campus.
- 8.2. Students enrolled in COLLEGE courses offered as part of this CCAP Agreement at the SCHOOL DISTRICT shall be held to the same grading standards as those expected of students in courses taught on the COLLEGE campus.
- 8.3. Students enrolled in COLLEGE courses offered as part of this CCAP Agreement at the SCHOOL DISTRICT shall be assessed using the same methods (e.g., papers, portfolios, quizzes, labs, etc.) as students in courses taught on the COLLEGE campus.
- 8.4. Students enrolled in COLLEGE courses offered as part of this CCAP Agreement at the SCHOOL DISTRICT shall be held to the same behavioral standards as those expected of students in courses taught on the COLLEGE campus.

9. LIAISON AND COORDINATION OF RESPONSIBILITIES

- 9.1. The COLLEGE shall appoint an educational administrator who will serve as point of contact to facilitate coordination and cooperation between COLLEGE, SCHOOL DISTRICT, and HIGH SCHOOL in conformity with COLLEGE policies and standards. (Ed. Code, § 76004, subd. (c)(2).) Among other things, the COMMUNITY COLLEGE DISTRICT Educational Administrator and the SCHOOL DISTRICT Educational Administrator described in Section 9.2, shall collaborate to determine the process for timely receiving, investigating, and remediating complaints of sexual misconduct or other conduct covered by Title IX of the Education Amendments of 1972 alleged to have occurred in or related to the CCAP program.

- 9.2. The SCHOOL DISTRICT shall appoint an educational administrator who will serve as point of contact to facilitate coordination and cooperation between SCHOOL DISTRICT, COLLEGE, HIGH SCHOOL in conformity with SCHOOL DISTRICT policies and standards.
- 9.3. This CCAP Agreement requires an annual report to the office of the Chancellor of the California Community Colleges by COLLEGE and SCHOOL DISTRICT. COLLEGE shall complete and file the Apportionment Attendance Report (CCFS-320); SCHOOL DISTRICT agrees to provide the following information, when requested by COLLEGE, in accordance with AB 288 Section 2, Education Code Section 76004:
- a. The total number of high school students by school site enrolled in each partnership, aggregated by gender and ethnicity, and reported in compliance with all applicable state and federal privacy laws.
 - b. The total number of community college courses by course category and type and by school site enrolled in by CCAP partnership participants.
 - c. The total number and percentage of successful course completions, by course category and type and by school site, of CCAP partnership participants.
 - d. The total number of full-time equivalent students generated by CCAP partnership community college district participants.

10. DISPUTES

- 10.1. COLLEGE and SCHOOL DISTRICT recognize that, from time to time, disputes may arise between COLLEGE employees or students and SCHOOL DISTRICT employees or students. When such disputes arise, COLLEGE and SCHOOL DISTRICT shall collaborate and use their best efforts to resolve them informally. Where informal resolution is not successful or the PARTIES must address a formal inter-agency complaint, the following process will be utilized to resolve the matter.
- a. The PARTY receiving the complaint will timely notify the other, and promptly provide the other PARTY with any written complaint received.
 - b. The Educational Administrators will review the complaint to determine, based on the nature of the complaint, whether any statutory or regulatory timelines or other procedural requirements apply, including but not limited to:
 - 10.1.b.1. Whether COLLEGE is required to investigate the complaint to the State Chancellor pursuant to Title 5 of the California Code of Regulations.
 - 10.1.b.2. Whether, based on the nature of the complaint, the complainant is entitled to any rights or protections with regard to how the complaint is handled, pursuant to Title 5 or applicable state or federal laws, including but not limited to Title IX of the Education Amendments of 1972.
 - 10.1.b.3. If either Educational Administrator finds such rights to exist, he or she shall notify the other Educational Administrator, and COLLEGE and SCHOOL DISTRICT shall cooperate as needed in carrying out these requirements. It is understood that such requirements may include but are not limited to conducting a formal investigation within regulatory timelines or the implementation of interim safety measures for the complainant.

- c. Within a reasonable time, either PARTY receiving the complaint, the PARTIES will discuss the nature and severity of the allegations and come to a mutual agreement regarding the need for and scope of any investigation required. If it is agreed that a formal investigation is required, the PARTIES will mutually agree upon an investigator, who may be an outside investigator, or qualified employee of COLLEGE or SCHOOL DISTRICT. If the PARTIES agree to have the matter investigated internally by either a COLLEGE or SCHOOL DISTRICT employee, the other PARTY may designate an employee to attend all witness interviews. Where it is determined that an outside investigator will be used, the cost will be divided between the PARTIES.
- d. If, despite the good faith effort of the PARTIES, they are unable to agree on a process for investigating the complaint, the PARTY whose employee/student is the subject of the complaint will determine the process.
- e. The COLLEGE and SCHOOL DISTRICT will cooperate in any investigation initiated and make its employees available to the investigator.
- f. Interviews of COLLEGE and SCHOOL DISTRICT employees shall comply with any rights and protections afforded to them under an applicable collective bargaining agreement or state or federal law, including but not limited to the right to have a representative present during an interview that could lead to discipline.
- g. The investigator will prepare a report that will be provided to both PARTIES setting forth findings as to the allegations and the basis for the findings.
- h. The COLLEGE and SCHOOL DISTRICT shall share any and all materials from the investigation, unless sharing would cause a PARTY to violate confidentiality or privacy laws.
- i. The COLLEGE and SCHOOL DISTRICT have sole discretion in determining any disciplinary measures to be imposed against their respective employees or students.
- j. Regardless of any disciplinary measures taken by the COLLEGE or SCHOOL DISTRICT against its respective employees or students, the other PARTY retains the right to have the subject of a sustained complaint removed from participating in or providing services for the program that is the subject of this CCAP Agreement.

11. APPORTIONMENT

- 11.1. COLLEGE shall include the students enrolled in a CCAP Agreement course in its report of full-time equivalent students (FTES) for purposes of receiving state apportionments when the course(s) complies with current requirements for dual enrollment under applicable California law.
- 11.2. For purposes of allowances and apportionments from Section B of the State School Fund, a community college district conducting a closed course on a high school campus shall be credited with those units of full-time equivalent students attributable to the attendance of eligible high school pupils.
- 11.3. The COLLEGE shall not receive a state allowance or apportionment for an instructional activity for which the SCHOOL DISTRICT has been, or shall be, paid an allowance or apportionment. (Ed. Code § 76004, subdivision (o)(2)).
- 11.4. The attendance of a SCHOOL DISTRICT pupil at the COLLEGE as a special part-

time or full-time student pursuant to this section is authorized attendance for which the COLLEGE shall be credited or reimbursed pursuant to Section 48802 or 76002, provided that no school district has received reimbursement for the same instructional activity.

12. CERTIFICATIONS

12.1. The SCHOOL DISTRICT certifies that:

- a. The direct education costs of the courses offered as part of this CCAP Agreement are not fully funded through other sources.
- b. It agrees and acknowledges that the COLLEGE will claim apportionment for the SCHOOL DISTRICT students enrolled in community college course(s) under this CCAP Agreement.
- c. Any COLLEGE instructor teaching a course at the SCHOOL DISTRICT has not displaced or resulted in the termination of an existing high school teacher teaching the same course on that high school campus.

12.2. The COLLEGE certifies that:

- a. A community college course offered for college credit at the participating SCHOOL DISTRICT does not reduce access to the same course offered at the partnering COLLEGE.
- b. The COLLEGE has not received full compensation for the direct education costs for the conduct of the courses offered as part of this CCAP Agreement from other sources.
- c. The Agreement is consistent with the core mission of the COLLEGE pursuant to Section 66010.4 and students participating in this CCAP Agreement will not lead to displacement of otherwise eligible adults at the COLLEGE.
- d. A qualified SCHOOL DISTRICT instructor teaching a course offered for college credit at a high school campus has not displaced or resulted in the termination of an existing COLLEGE faculty member teaching the same course at the partnering community college campus.

12.3. The PARTIES certify that:

- a. Any COLLEGE instructor teaching a course on a SCHOOL DISTRICT campus has not been convicted of any sex offense as defined in Education Code section 44010 or as amended, or any controlled substance offense as defined in Education Code section 44011 or as amended.
- b. The SCHOOL DISTRICT and COLLEGE comply with local collective bargaining agreements and all state and federal reporting requirements regarding the qualifications of the teacher or faculty member teaching a CCAP Agreement course offered for high school credit. (AB288 Sec. 2 (I).)

13. PROGRAM IMPROVEMENT

13.1. The COLLEGE and the SCHOOL DISTRICT may annually conduct surveys of

participating SCHOOL DISTRICT pupils, instructors, principals, and school counselors for the purpose of informing practice, adjusting, and improving the quality of courses offered as part of this CCAP Agreement.

14. RECORDS

- 14.1. Permanent records of student attendance, grades and achievement will be maintained by both the SCHOOL DISTRICT and COLLEGE for SCHOOL DISTRICT students who enroll in course(s) offered as part of this CCAP Agreement. Permanent records of student enrollment, grades, and achievement for COLLEGE students shall be maintained by COLLEGE.
- 14.2. Each PARTY shall maintain records pertaining to this CCAP Agreement as may be required by federal and state law. Each PARTY may review and obtain a copy of the other PARTY'S pertinent records subject to federal and state privacy statutes.
- 14.3. SCHOOL DISTRICT instructors will submit grades to the COLLEGE when due according to the COLLEGE schedule per section 7.14. The SCHOOL DISTRICT will include all criteria identified by the COLLEGE for grading purposes.
- 14.4. COLLEGE may provide the SCHOOL DISTRICT with a report on participating students' final grades after each term.

15. CCAP AGREEMENT DATA MATCH AND REPORTING

- 15.1. COLLEGE and SCHOOL DISTRICT shall ensure operational protocols consistent with the collection of participating student data and the timely submission of the data.
- 15.2. COLLEGE shall report all program and participating student data to the office of the Chancellor of the California Community Colleges.

16. DATA SHARING

- 16.1. COLLEGE and SCHOOL DISTRICT may share confidential student data for the purposes of evaluating the educational services provided under this CCAP agreement and for evaluating student performance pursuant to participating in CCAP courses. Any data shared will be for research and analytical purposes aimed at understanding student performance and improving applicable federal and state laws concerning access to and confidentiality of student record information as described in Section 17 of this agreement.

17. PRIVACY OF STUDENT RECORDS

- 17.1. COLLEGE and SCHOOL DISTRICT understand and agree that education records of students enrolled in a CCAP course and personally identifiable information contained in those educational records are subject to the Family Educational Rights and Privacy Act (FERPA) 20 U.S.C. § 1232g; 34 C.F.R. Part 99, including the disclosure provisions of § 99.30 and state law as outlined in Education Code section 49064 and section 49076). COLLEGE and SCHOOL DISTRICT agree to hold all student education records generated pursuant to this CCAP Agreement in strict confidence and further agree not to disclose such records except as authorized by applicable law or regulation for COLLEGE

records or by the parent or guardian's prior written consent for HIGH SCHOOL records. (34 C.F.R. § 99.33 (a), (b); 34 C.F.R. § 99.34(b) and Education Code §§ 49064 and 49076.)

- 17.2. **Limitation on Use.** COLLEGE and SCHOOL DISTRICT shall use each student education record that they may receive pursuant to this CCAP Agreement solely for purposes consistent with their authority to access that information pursuant to Federal and State law, as may be as applicable. (34 C.F.R. § 99.31, 34 C.F.R. § 99.34, and Education Code § 49076.)
- 17.3. **Recordkeeping Requirements.** COLLEGE and SCHOOL DISTRICT shall comply with the requirements governing maintenance of records of each request for access to and each disclosure of student education records set forth under Title 34, Code of Federal Regulations § 99.32 and under Education Code § 49064 as applicable.
- 17.4. **Acknowledgement of Receipt of Notice of FERPA Regulations.** By signature of its authorized representative or agent on this Agreement, COLLEGE and SCHOOL DISTRICT hereby acknowledges that it has been provided with the notice required under 34 C.F.R. § 99.33(d) that it is strictly prohibited from re-disclosing student education records to any other person or entity except as authorized by applicable law or regulation. Parent or guardian requests for information will need to be addressed directly by the HIGH SCHOOL or SCHOOL DISTRICT personnel.

18. REIMBURSEMENT

- 18.1. The SCHOOL DISTRICT shall invoice the COLLEGE no later than 30 (thirty) days after the start of each term for the instructional services provided through this CCAP agreement as follows:
- a. For courses taught by COLLEGE-approved SCHOOL DISTRICT teachers and COLLEGE instructors on HIGH SCHOOL campuses during regular high school hours rendered at the rate of \$1,000.00 per course unit delivered to CCAP students.

Example: 3 CCAP courses @ 3 units each = 9 units x \$1,000.00 = \$9,000.00

- 18.2. The COLLEGE shall make payment to the SCHOOL DISTRICT within 30 days of receiving the invoice for instructional services rendered.
- 18.3. The COLLEGE is required to report to the state the percentage of funds paid to an agency to the SCHOOL DISTRICT that will provide direct instruction on behalf of the college as part of the CCAP partnership agreement. The SCHOOL DISTRICT will use 100% of all funds received from Allan Hancock College in fulfillment of this agreement to pay for direct instructional costs. (Ed. Code § 84632).

19. FACILITIES

- 19.1. The SCHOOL DISTRICT will provide adequate classroom space at its facilities or other mutually agreed upon locations to conduct the instruction and do so without charge to COLLEGE or students. SCHOOL DISTRICT agrees to clean, maintain, and safeguard SCHOOL DISTRICT's premises. SCHOOL DISTRICT warrants that its facilities are safe and compliant with all applicable buildings, fire, and safety codes.

- 19.2. The SCHOOL DISTRICT will furnish, at its own expense, all course materials, specialized equipment, books and other necessary equipment for all SCHOOL DISTRICT students. The parties understand that such equipment and materials are the SCHOOL DISTRICT's sole property.
- 19.3. The SCHOOL DISTRICT facilities may be used by COLLEGE for COLLEGE course offerings before or after regular high school schedule at no additional cost. Prior approval by the SCHOOL DISTRICT is required. COLLEGE courses offered before or after the regular high school schedule will be open to the public.

20. INDEMNIFICATION

20.1. The SCHOOL DISTRICT agrees to and shall indemnify, save and hold harmless the COLLEGE, and its governing board, officers, employees, administrators, independent contractors, subcontractors, agents and other representatives from any and all claims, demands, liabilities, costs, expenses, damages, causes of action, losses, and judgments, arising out of SCHOOL DISTRICT's performance of this CCAP Agreement. The obligation to indemnify shall extend to all claims and losses that arise out of SCHOOL DISTRICT's or its trustees', officers', agents', or employees' negligence, wrongful acts or omissions, or willful misconduct related to this CCAP Agreement or performance of this CCAP Agreement. The provisions of this section shall survive the termination or expiration of this CCAP Agreement.

20.2. The COLLEGE agrees to and shall indemnify, save and hold harmless the SCHOOL DISTRICT and its governing board, officers, employees, administrators, independent contractors, subcontractors, agents and other representatives from any and all claims, demands, liabilities, costs, expenses, damages, causes of action, losses, and judgments, arising out of COLLEGE'S performance of this CCAP Agreement. The obligation to indemnify shall extend to all claims and losses that arise out of COLLEGE'S or its trustees', officers', agents', or employees' negligence, wrongful acts or omissions, or willful misconduct related to this CCAP Agreement or performance of this CCAP Agreement. The provisions of this section shall survive the termination or expiration of this CCAP Agreement.

21. INSURANCE

21.1. The SCHOOL DISTRICT, in order to protect the COLLEGE, its agents, employees and officers against claims and liability for death, injury, loss and damage arising out of or in any manner connected with the performance and operation of the terms of this CCAP Agreement, shall secure and maintain in force during the entire term of this CCAP Agreement, insurance coverage or an approved program of self-insurance in the amount of not less than ONE MILLION DOLLARS (\$1,000,000) per incident and TWO MILLION DOLLARS (\$2,000,000) general aggregate for personal injury, bodily injury, death, and property and other damage, with an admitted California insurer duly licensed to engage in the business of insurance in the State of California, or public entity risk management Joint Powers Authority, authorized to provide public liability and property damage insurance in the state of California. Said policy of insurance, insurance coverage through a public entity risk management JPA, or program of self-insurance shall expressly name the COLLEGE, its

agents, employees and officers as an additional insured for the purposes of this CCAP Agreement. A certificate of insurance including such endorsement shall be furnished to the COLLEGE.

- 21.2. The COLLEGE, in order to protect the SCHOOL DISTRICT, its agents, employees and officers against claims and liability for death, injury, loss and damage arising out of or in any manner connected with the performance and operation of the terms of this CCAP Agreement, shall secure and maintain in force during the entire term of this CCAP Agreement, insurance coverage or an approved program of self- insurance in the amount of not less than ONE MILLION DOLLARS (\$1,000,000) per incident and TWO MILLION DOLLARS (\$2,000,000) general aggregate for personal injury, bodily injury, death, and property and other damage, with an admitted California insurer duly licensed to engage in the business of insurance in the State of California, or public entity risk management Joint Powers Authority, authorized to provide public liability and property damage insurance in the State of California. Said policy of insurance, insurance coverage through a public entity risk management JPA or program of self-insurance shall expressly name the SCHOOL DISTRICT, its agents, employees and officers as an additional insured for the purposes of this CCAP Agreement. A certificate of insurance including such endorsement shall be furnished to the SCHOOL DISTRICT.
- 21.3. For the purpose of Workers' Compensation, SCHOOL DISTRICT shall be the "primary employer" for all its employees who perform services as instructors and support staff. SCHOOL DISTRICT shall be solely responsible for processing, investigating, defending, and paying all workers' compensation claims by their respective SCHOOL DISTRICT employees made in connection with performing services and receiving instruction under this CCAP Agreement. SCHOOL DISTRICT agrees to hold harmless, indemnify, and defend COLLEGE, its directors, officers, agents, and employees from any liability resulting from its failure to process, investigate, defend, or pay any workers' compensation claims by SCHOOL DISTRICT employees connected with providing services under this CCAP Agreement.

22. NON-DISCRIMINATION

- 22.1. Neither the SCHOOL DISTRICT nor the COLLEGE shall discriminate on the basis of race or ethnicity, gender, nationality, physical or mental disability, sexual orientation, religion, or any other protected class under California State or federal law.

23. NOTICES

- 23.1. Any and all notices required to be given hereunder shall be deemed given when personally delivered or deposited in the U.S. Mail, postage to be prepaid, to the following addresses:

Allan Hancock College Joint Community College District
 800 S. College Drive
 Santa Maria, CA 93460
 Attn: Dennis Curran

Santa Maria Joint Union High School District
 2560 Skyway Drive
 Santa Maria, Ca 93455
 Attn: Antonio Garcia

24. MODIFICATION AND AMENDMENT

- 24.1. Appendix A through D to this CCAP Agreement is incorporated by this reference into this CCAP Agreement.
- 24.2. This CCAP Agreement and Appendix A through D to this CCAP Agreement set forth the entire agreement between the PARTIES relating to the subject matter of this CCAP Agreement. This CCAP Agreement and Appendix A through D to this CCAP Agreement supersede any prior agreements, promises, negotiations, or representations, express or implied, oral or written, not included in this CCAP Agreement and Appendix A through D to this CCAP Agreement.
- 24.3. This Agreement may be amended only with the mutual consent of the Parties. All amendments must be in writing and must be approved by the Parties' respective governing Boards.

25. GOVERNING LAWS

- 25.1. This CCAP Agreement will be governed by and construed in accordance with California law, and the venue of any action or proceeding in connection with this CCAP Agreement shall be Santa Barbara County, California.

26. COMMUNITY COLLEGE DISTRICT BOUNDARIES

- 26.1. For locations outside the geographical boundaries of Allan Hancock College Joint Community College District, the COLLEGE will comply with the requirements of Title 5 of the California Code of Regulations, Sections 55300 et seq. or as amended, concerning approval by adjoining high school or community college districts and use of non-district facilities.

27. SEVERABILITY

- 27.1. This CCAP Agreement shall be considered severable, such that if any provision or part of the CCAP Agreement is ever held invalid under any law or ruling, that provision or part of the CCAP Agreement shall remain in force and effect to the extent allowed by law, and all other provisions or parts shall remain in full force and effect.

28. COUNTERPARTS

- 28.1. This CCAP Agreement may be executed by the PARTIES in separate counterparts, each of which when so executed and delivered shall be an original, but all such counterparts shall together constitute one and the same instrument.

IN WITNESS WHEREOF, the PARTIES hereto have caused this CCAP Agreement to be executed on the dates set forth below, to be effective as of the Effective Date.

ALLAN HANCOCK JOINT COMMUNITY
COLLEGE DISTRICT

SANTA MARIA JOINT UNION
HIGH SCHOOL DISTRICT

By: _____
Associate Superintendent/Vice President of
Finance and Administration

By: _____
Superintendent

Date: _____

Date: _____

ALLAN HANCOCK JOINT COMMUNITY
COLLEGE DISTRICT BOARD MEETINGS

SANTA MARIA JOINT UNION HIGH
SCHOOL DISTRICT BOARD MEETINGS

Information Board Meeting Date:

Information Board Meeting Date:

Public Comment
and Approval Board Meeting Date:

Public Comment
and Approval Board Meeting Date:

APPENDIX A

ALLAN HANCOCK COLLEGE JOINT COMMUNITY COLLEGE DISTRICT

Agreement with INSTRUCTOR

This agreement is made and entered into this _____ [day] of _____ [month] ____ [year] by three parties: The Allan Hancock College Joint Community College District (hereinafter “COLLEGE”), the _____ [high school district] (hereinafter “SCHOOL DISTRICT”) and _____ [first name, last name], an employee of the SCHOOL DISTRICT (hereinafter “INSTRUCTOR”) who is being assigned to the COLLEGE on a part-time basis pursuant to Title 5, California Code of Regulations, section 58058(b).

WHEREAS, the SCHOOL DISTRICT has the experience, training, equipment and other resources, and staff necessary to provide instruction to COLLEGE students through the CCAP Agreement;

WHEREAS, Title 5, California Code of Regulations, section 58050, subdivision (a) provides authority for claiming apportionment;

NOW, THEREFORE, the three parties to this Agreement hereby agree as follows:

1. The SCHOOL DISTRICT’s INSTRUCTOR is an employee of the SCHOOL DISTRICT who shall meet “Minimum Qualifications” for the academic position of COLLEGE’s INSTRUCTOR as established by the COLLEGE and as determined by the COLLEGE.
2. The SCHOOL DISTRICT’s INSTRUCTOR is professionally and specially trained and competent to provide the supervisory and/or instructional services required by the COLLEGE.
3. The INSTRUCTOR will be an employee of the COLLEGE for purposes of the Attendance Accounting Standards (Ed. Code, § 58050). COLLEGE has the right to; 1) evaluate and terminate INSTRUCTOR; 2) evaluate the quality of instruction to ensure that it meets the needs of students; 3) evaluate the quality and rigor equal to the COLLEGE’S approved course outline of record and the accreditation requirements of COLLEGE. The COLLEGE will not provide INSTRUCTOR evaluation results to the SCHOOL DISTRICT.
4. The SCHOOL DISTRICT’s INSTRUCTOR shall at all times comply with the supervisory and/or instructional requirements outlined in Title 5, California Code of Regulations, section 58055, which require direct instruction by the SCHOOL DISTRICT’s INSTRUCTOR except in limited circumstances. The SCHOOL DISTRICT’s INSTRUCTOR’s responsibilities and duties as an employee of the COLLEGE shall include, but are not limited to, the following:
 - 4.1. Ensure that an instructional time of 50 minutes per class each day is expended in full compliance with the course objectives determined by the COLLEGE.
 - 4.2. Ensure the safety and well-being of students.
 - 4.3. Be in sufficient physical proximity and range of communication to provide immediate instructional supervision and control of all students in his/her classes.
 - 4.4. Attend periodic staff meetings with the COLLEGE.
 - 4.5. Regularly check and respond to communication from COLLEGE.
 - 4.6. Priority in class enrollment shall be given to students desiring to take the course for college credit towards a degree or certificate (Ed. Code § 76370). Ensure accurate and current daily student attendance records, accurate calculation of final student grades of

all students enrolled in the course for college credit, and the prompt submission of all data necessary for the calculation of FTES to the DISTRICT within 3 (three) calendar days of course completion (Ed. Code § 84500).

- 4.7. Ensure the effective use of instructional methods, technology, testing and remediation.
 - 4.8. Ensure that he/she does not have any other assigned duties during the instructional activity where multiple skill levels of students are being taught for which attendance is being claimed.
 - 4.9. Be familiar with and comply with all relevant COLLEGE policies, rules and regulations, including but not limited, to those related to student safety, grading, attendance, sexual harassment and discrimination.
 - 4.10. Provide support to SCHOOL DISTRICT students taking COLLEGE courses under CCAP agreement with COLLEGE admission and registration procedures.
5. The SCHOOL DISTRICT shall indemnify and hold harmless the COLLEGE and its authorized agents, officers, and employees against any and all claims and actions arising from the SCHOOL DISTRICT's INSTRUCTOR's or SCHOOL DISTRICT's negligent, reckless or intentional acts, errors or omissions and for any cost or expense incurred by the COLLEGE on account of any claim therefor.
 6. The COLLEGE shall provide no compensation to the SCHOOL DISTRICT's INSTRUCTOR for any services rendered pursuant to this Agreement, but compensation, as well as workers' compensation insurance, shall be the responsibility of the SCHOOL DISTRICT in accordance with its established and standard practices.
 7. This Agreement may be terminated at any time by the COLLEGE within the sole and exclusive discretion of the COLLEGE upon written notice to the SCHOOL DISTRICT and the SCHOOL DISTRICT's INSTRUCTOR. This Agreement may be terminated upon thirty (30) days' prior written notice to COLLEGE by either the SCHOOL DISTRICT or the SCHOOL DISTRICT's INSTRUCTOR within either's sole and exclusive discretion.

IN WITNESS WHEREOF, the parties hereto have executed this Agreement the day and year last written below.

INSTRUCTOR

ALLAN HANCOCK COLLEGE JOINT
COMMUNITY COLLEGE DISTRICT

Print

Print

Signature

Signature

APPENDIX B

Identification of CCAP Pathways for Course-Specific College and Career Pathway Opportunities

Pursuant to California Assembly Bill No. 288, the COLLEGE and SCHOOL DISTRICT enter into this partnership agreement to offer College and Career Pathways (CCAP) to high school students to expand dual enrollment opportunities to facilitate college and career readiness, particularly among students who may not already be college-bound or who are underrepresented in higher education.

The goal of the CCAP partnership is to offer seamless pathways from high school to community college to promote: 1) academic preparation for transfer to four-year colleges and universities; 2) completion of career and technical education programs for entry into the workforce; (3) improving high school graduation rates, and (4) helping high school pupils achieve college and career readiness.

The following pathways are included in the CCAP partnership agreement between the COLLEGE and SCHOOL DISTRICT:

Career and Technical Education:

1. This pathway includes COLLEGE courses in a Career and Technical education (“CTE”) pathway at the college level that apply to an Allan Hancock College degree or certificate in the pathway. This includes:
 - a. Naming of HIGH SCHOOL Pathway and Course Location in Sequence (Introductory, Concentrator, Capstone, or Practicum)
 - b. Naming of COLLEGE Pathway – Degree or Certificate
 - c. Identifying Career/Employment Outcomes associated with CTE Pathway
 - d. Identifying the course(s) in the Pathway to be offered under the CCAP Agreement.
2. Examples of CTE Technical Pathways include Automotive, Digital Art and Graphic Design, Culinary, Early Childhood Studies, Welding etc.

College and Career Readiness:

1. This pathway includes COLLEGE courses in career exploration and career development that prepare students in college and career planning. Successful completion of these courses will allow students to matriculate at college level in courses in a CTE pathway or General Education/California State University (“CSU”) Transfer pathway.
2. Course examples include: WEE (Work Experience); PD (Career Planning).

Preparation for Transfer:

1. California General Education Transfer Curriculum (Cal-GETC). This pathway includes COLLEGE courses which have been approved to meet the lower-division general education requirements at any CSU or University of California campus (i.e. Areas 1-6)

Improve High School Graduation Rates:

1. Student participation in college courses improves graduation rates of students who participate compared to peers who do not participate in college-level coursework.

APPENDIX C

CCAP Agreement Courses Approved for 2025 – 2026

HIGH SCHOOL DISTRICT: Santa Maria Joint Union High School District

HIGH SCHOOL SITE: Ernest Righetfi High School

PROJECTED NUMBER OF STUDENTS TO BE SERVED: 1,843

TOTAL PROJECTED FTES: 294.83

CCAP Pathway	College Degree or Certificate	High School Pathway	CCAP Course Offerings		Number of Sections, High School period(s) & Times		Instructor Name & Employer of Record (AHC or HS)	Projected Number of Students	Projected FTES
			FALL	SPRING	FALL	SPRING			
Career Technical Education	Agricultural Science - AS	Agricultural Business	AG 150	AG 157	1 section Period 5 1:05-1:55 pm	1 section Period 5 1:05-1:55 pm	Amy Guerra (HS)	36	7.41
Career Technical Education	Agricultural Science - AS	Agricultural Business	AG 158	American Government Agriculture	1 section Period 2 9:30-10:20 am	high school course	Guillermo Guerra (HS)	36	3.70
Career Technical Education	Agricultural Science - AS	Agricultural Business	Animal Science	AG 152	high school course	1 section Period 3 10:35-11:25 am	Miguel Guerra (HS)	36	3.70
Career Technical Education	Welding Technology - CA	Agricultural Mechanics	WLDLT 300	WLDLT 106	1 section Period 4 11:35 am-12:25 pm	1 section Period 4 11:35 am-12:25 pm	Miguel Guerra (HS)	36	11.10
Career Technical Education	Sports Medicine - AS	Patient Care	WEE 149	ATH 104	2 sections TBD	2 sections Periods 2-3 9:30-10:20am, 10:35-11:25am	AHC (TBD)	72	10.56
Career Technical Education	Administration of Justice - AS	Early College Pathway	AJ 101	AJ 103	2 sections TBD	1 section TBD	TBD (AHC)	75	7.71

Career Technical Education	Early Childhood Education – AA-T	Early College Pathway	ECS 100	ECS 101	2 sections TBD	2 sections TBD	TBD (AHC)	TBD (AHC)	50	5.14
Career Technical Education	Early Childhood Education – AA-T	Early College Pathway	EDUC 149	ECS 149	1 section TBD	1 section TBD	TBD (AHC)	TBD (AHC)	20	4.12
Career Technical Education	Elementary Teacher Education – AA-T	Early College Pathway	EDUC 130	EDUC 132	2 sections TBD	2 sections TBD	TBD (AHC)	TBD (AHC)	50	17.14
Preparation for Transfer	AA-T Cal-GETC	Early College Pathway	English 3 Honors	ENGL C1000	high school course	high school course	Roxanne Leasure (HS)	Roxanne Leasure (HS)	36	4.94
Preparation for Transfer	AA-T Cal-GETC	Early College Pathway	English 3 Honors	ENGL C1000	high school course	high school course	Daniel Bulone (HS)	Daniel Bulone (HS)	180	24.69
Preparation for Transfer	AA-T Cal-GETC	Early College Pathway	English 4 Honors	ENGL C1001	high school course	high school course	Roxanne Leasure (HS)	Roxanne Leasure (HS)	144	14.81
Preparation for Transfer	AS-T Cal-GETC	Environmental Resources	HS Biology	BIOL 100	high school course	high school course	Rebecca Wingerden (HS)	Rebecca Wingerden (HS)	72	14.81
Preparation for Transfer	AS-T Cal-GETC	Environmental Resources	HS Geology	GEOL 101	high school course	high school course	Laura Branch (HS)	Laura Branch (HS)	72	14.81
Preparation for Transfer	Film and Video Production - CA	Production and Managerial Arts	HS Film	FILM 110	1 section Period 1 8:30-9:20 am	high school course	Jacob Gustafson (HS)	Jacob Gustafson (HS)	36	7.41
Preparation for Transfer	Ballet Folklórico - CA	Performing Arts	DANC 142	DANC 145	1 section Period 7 3:05-3:55pm	1 section Period 7 3:05-3:55pm	Ricardo Gabaldon (HS)	Ricardo Gabaldon (HS)	36	7.41

Preparation for Transfer	Ballet Folklorico - CA	Performing Arts	Beginning Folklorico (HS)	DANC 140	high school course	1 Section Period 5 1:05-1:55 pm	Ricardo Gabaldon (HS)	36	11.11
Preparation for Transfer	AA-T Cal-GETC	Early College Pathway	HIST 101	WEE 382 WEE 149 (courses rotate)	1 section 1 section TBD	1 section 1 section TBD	Ricardo Gabaldon (HS)	108	22.22
Preparation for Transfer	AA-T Cal-GETC	Early College Pathway	PSYC C1000	HIST 102	3 sections Periods 2-4 9:30-10:20am 10:35-11:25am 11:35-12:25pm	3 sections Periods 2-4 9:30-10:20am 10:35-11:25am 11:35-12:25pm	Andrew Domingues (HS)	30	6.17
Preparation for Transfer	AA-T Cal-GETC	Early College Pathway	PSYC C1000	SOC 101	1 section TBD	1 section TBD	TBD (AHC)	30	6.17
Preparation for Transfer	AA-T Cal-GETC	Early College Pathway	ART 101	MUS 100	1 section TBD	1 section TBD	TBD (AHC)	30	6.17
Preparation for Transfer	AA-T Cal-GETC	Early College Pathway	HIST 120	ES 120	2 sections TBD	2 sections TBD	TBD (AHC)	60	12.34
Preparation for Transfer	AA-T Cal-GETC	Early College Pathway	PSY 117	PSY 118	1 section TBD	1 section TBD	TBD (AHC)	30	6.17
Preparation for Transfer	AA-T Cal-GETC	Early College Pathway	COMM C1000	BIOL 120	2 sections TBD	2 sections TBD	TBD (AHC)	50	10.29
Preparation for Transfer	AA-T Cal-GETC	Early College Pathway	ASL 120	ASL 121	2 sections TBD	2 sections TBD	Maria Rivera (AHC)	50	10.29
College & Career Readiness	AA GE	Freshmen Readiness	PROD 301 (paired with high school course "Intro to	PROD 301 (paired with high school course "Intro to	5 sections Periods 2-4, 6-7 9:30-10:20am 10:35-11:25am 11:35-12:25pm	5 sections Periods 2-4, 6-7 9:30-10:20am 10:35-11:25am 11:35-12:25pm	Edward Herrmann (HS)	360 cohorts rotate	37.03

College & Career Readiness	AA GE	Freshmen Readiness	Ethnic & Gender Studies")	Ethnic & Gender Studies")	2:05-2:55 pm 3:05-3:55 pm	2:05-2:55 pm 3:05-3:55 pm	Elias Garcia (HS)	Elias Garcia (HS)	72 cohorts rotate	7.41
			PROD 301 (paired with high school course "Intro to Ethnic & Gender Studies")	PROD 301 (paired with high school course "Intro to Ethnic & Gender Studies")	1 Section Period 1 8:30-9:20 am	1 Section Period 1 8:30-9:20 am	Elias Garcia (HS)	Elias Garcia (HS)		

1. **Required:** Describe the criteria used to assess the ability of pupils to benefit from the course(s) offered:

In consultation with their SCHOOL DISTRICT counselors, students self-select a pathway based on their academic readiness and alignment of course content to students' educational and career goals. SCHOOL DISTRICT and COLLEGE faculty identified CCAP courses using the following criteria:

- a. Alignment with HIGH SCHOOL pathways and COLLEGE programs of study.
- b. Potential for course completion to accelerate students' time to completion of postsecondary degree or certificate.
- c. Potential to earn a Certificate of Training and be eligible to enter the workforce in their selected career technical pathway.
- d. Potential to work toward completion of an associate degree or an associate degree for transfer.

2. **MINIMUM QUALIFICATIONS FOR INSTRUCTION:** All instructors teaching CCAP Agreement Courses must meet the minimum qualifications for instruction in a California community college as set forth in Title 5 of the California Code of Regulations, sections 53410 and 58060 or as amended. The minimum qualifications for instruction are:

Course Name & Number	Minimum Qualifications For Instructors
AG 150	<ul style="list-style-type: none"> • Any bachelor's degree or higher and two years of professional experience • OR any associate degree and six years of professional experience <p>NOTE: Professional experience is required when the application possesses a master's degree. The professional experience required must be directly related to the teaching assignment.</p> <ul style="list-style-type: none"> • OR master's degree in agriculture, agricultural science, education with a specialization in agriculture or other agricultural area, including agricultural business, agricultural engineering, agricultural mechanics, agronomy, animal science, enology, environmental (ornamental) horticulture, equine science, forestry, natural resources, plant science,

	<ul style="list-style-type: none"> • pomology, soil science, viticulture or other agriculture science • OR master's degree in business, business management, business administration, accountancy, finance, marketing or business education • OR bachelor's degree in any of the above AND master's degree in economics, personnel management, public administration, or Juris Doctor Degree (J.D.) or Legum Baccalaureus (LL.B.) • OR bachelor's degree in economics with a business emphasis AND master's in personnel management, public administration, or Juris Doctor Degree (J.D.) or Legum Baccalaureus (LL.B.) • OR master's degree in business administration, business management, business education, marketing, advertising or finance • OR bachelor's degree in any of the above AND master's degree in economics, accountancy, taxation or law • OR the equivalent
<p>AG 152</p>	<ul style="list-style-type: none"> • Any bachelor's degree or higher and two years of professional experience • OR any associate degree and six years of professional experience. <p>Professional experience is required when the application possesses a master's degree. The professional experience required must be directly related to the teaching assignment.</p> <ul style="list-style-type: none"> • OR a master's degree in agriculture, agricultural science, education with a specialization in agriculture or other agricultural area, including agricultural business, agricultural engineering, agricultural mechanics, agronomy, animal science, enology, environmental (ornamental) horticulture, equine science, forestry, natural resources, plant science, pomology, soil science, viticulture or other agriculture science • OR the equivalent
<p>AG 157</p>	<ul style="list-style-type: none"> • Any bachelor's degree or higher and two years of professional experience • OR any associate degree and six years of professional experience. <p>NOTE: Professional experience is required when the application possesses a master's degree. The professional experience required must be directly related to the teaching assignment</p> <ul style="list-style-type: none"> • OR a master's degree in agriculture, agricultural science, education with a specialization in agriculture or other agricultural area, including agricultural business, agricultural engineering, agricultural mechanics, agronomy, animal science, enology, environmental (ornamental) horticulture, equine science, forestry, natural resources, plant science, pomology, soil science, viticulture or other agriculture science • OR master's degree in business, business management, business administration, accountancy, finance, marketing or business education

	<ul style="list-style-type: none"> • OR bachelor's degree in any of the above AND master's degree in economics, personnel management, public administration, or Juris Doctor Degree (J.D.) or Legum Baccalaureus (LL.B.) OR bachelor's degree in economics with a business emphasis AND master's in personnel management, public administration, or Juris Doctor Degree (J.D.) or Legum Baccalaureus (LL.B.) • OR the equivalent
AG 158	<ul style="list-style-type: none"> • Master's degree in agriculture, agricultural science, education with a specialization in agriculture or other agricultural area, including agricultural business, agricultural engineering, agricultural mechanics, agronomy, animal science, enology, environmental (ornamental) horticulture, equine science, forestry, natural resources, plant science, pomology, soil science, viticulture or other agriculture science • OR the equivalent
AJ 101 AJ 103	<ul style="list-style-type: none"> • Any bachelor's degree or higher and two years of professional experience • OR any associate degree and six years of professional experience. <p>NOTE: Professional experience is required when the application possesses a master's degree. The professional experience required must be directly related to the teaching assignment.</p>
ART 101	<ul style="list-style-type: none"> • Master's degree in fine arts, art, or art history • OR bachelor's degree in any of the above AND master's degree in humanities • OR the equivalent <p>NOTE: "master's degree in fine arts" as used here refers to any master's degree in the subject matter of fine arts, which is defined to include visual studio arts such as drawing, painting, sculpture, printmaking, ceramics, textiles, and metal and jewelry art, and also art education and art therapy. It does not refer to the "Master of Fine Arts" (MFA) degree when that degree is based on specialization in performing arts or dance, film, video, photography, creative writing or other nonplastic arts.</p>
ASL 120 ASL 121	<ul style="list-style-type: none"> • Master's degree in American Sign Language • OR bachelor's degree in American Sign Language AND master's degree in another language or linguistics • OR the equivalent
ATH 104	<ul style="list-style-type: none"> • Any bachelor's degree or higher and two years of professional experience • OR any associate degree and six years of professional experience. <p>NOTE: Professional experience is required when the application possesses a master's degree. The professional experience required must be directly related to the teaching assignment.</p>

BIOL 100 BIOL 120	<ul style="list-style-type: none"> • Master's degree in any biological science • OR bachelor's degree in any biological science AND master's degree in biochemistry, biophysics, or marine science • OR the equivalent
COMM C1000	<ul style="list-style-type: none"> • Master's degree in speech, speech broadcasting, telecommunications, rhetoric, communication, communication studies, speech communication or organizational communication • OR bachelor's degree in any of the above AND master's degree in drama/theater arts, mass communication or English • OR the equivalent
DANC 140	<ul style="list-style-type: none"> • Master's degree in dance, physical education with a dance emphasis, or theater with dance emphasis • OR bachelor's degree in any of the above AND master's degree in physical education, any life science, physiology, theater arts, kinesiology, humanities, performing arts or music • OR any bachelor's degree or higher and two years of professional experience in Folk Dance • OR any associate degree and six years of professional experience in Folk Dance. • Professional experience is required when the application possesses a master's degree. The professional experience required must be directly related to the teaching assignment • OR the equivalent
DANC 142	<ul style="list-style-type: none"> • Master's degree in dance, physical education with a dance emphasis, or theater with dance emphasis • OR bachelor's degree in any of the above AND master's degree in physical education, any life science, physiology, theater arts, kinesiology, humanities, performing arts or music • OR the equivalent
DANC 145	<ul style="list-style-type: none"> • Master's degree in dance, physical education with a dance emphasis, or theater with dance emphasis, with professional experience in Folklorico • OR bachelor's degree in any of the above AND master's degree in physical education, any life science, physiology, theater arts, kinesiology, humanities, performing arts or music AND professional experience in Folklorico • OR the equivalent
ECS 100 ECS 101	<ul style="list-style-type: none"> • Master's degree in child development, early childhood education, human development, home economics/family and consumer studies with a specialization in child development/early childhood education or educational psychology with a specialization in child development/early childhood education • OR bachelor's degree in any of the above AND master's in social work, educational

	<p>supervision, elementary education, special education, psychology, bilingual/bicultural education, life management/home economics, family life studies or family and consumer studies</p> <ul style="list-style-type: none"> • OR the equivalent
EDUC 130	<ul style="list-style-type: none"> • Master's degree in education • OR the equivalent
EDUC 132	<ul style="list-style-type: none"> • Master's degree in child development, early childhood education, human development, home economics/family and consumer studies with a specialization in child development/early childhood education or educational psychology with a specialization in child development/early childhood education • OR bachelor's degree in any of the above AND master's in social work, educational supervision, elementary education, special education, psychology, bilingual/bicultural education, life management/home economics, family life studies or family and consumer studies • OR master's degree in education • OR the equivalent
ENGL C1000 ENGL C1001	<ul style="list-style-type: none"> • Master's degree in English, literature, comparative literature, or composition • OR bachelor's degree in any of the above AND master's degree in linguistics, TESL, speech, or education with a specialization in reading, creative writing or journalism • OR the equivalent
ES 120	<ul style="list-style-type: none"> • Master's degree in African American Studies, Black Studies, Africana Studies, Latino Studies, La Raza Studies, Chicana/o Studies, Asian American Studies, Native American Studies, or American Indian Studies • OR master's degree in Ethnic Studies • OR the equivalent
FILM 110	<ul style="list-style-type: none"> • Master's degree in film/cinema and media studies, film, television, and media studies, drama/theater, and mass communication • OR bachelor's degree in any of the above AND master's degree in visual studies, media studies, English, or communication • OR the equivalent
GEOG 100	<ul style="list-style-type: none"> • Master's degree in geology, geophysics, earth sciences, meteorology, oceanography or paleontology • OR bachelor's degree in geology AND master's degree in geography, physics, or geochemistry • OR the equivalent

	<ul style="list-style-type: none"> • OR master's degree in the interdisciplinary area • OR master's degree in one of the disciplines included in the interdisciplinary area and upper division or graduate course work in at least one other constituent discipline <p>NOTE: The Interdisciplinary Studies discipline is provided to allow for those cases where it is locally determined that a course must be taught by someone with qualifications that exceed a single discipline. The constituent disciplines can include any disciplines found in the Master's List.</p>
HIST 101 HIST 102	<ul style="list-style-type: none"> • Master's degree in history • OR bachelor's degree in history AND master's degree in political science, humanities, geography, area studies, women's studies, social science or ethnic studies • OR the equivalent
HIST 120	<ul style="list-style-type: none"> • Master's degree in Chicano Studies • OR master's degree in African American Studies, Black Studies, Africana Studies, Latino Studies, La Raza Studies, Chicana/o Studies, Asian American Studies, Native American Studies, or American Indian Studies • OR master's degree in ethnic studies • OR master's degree in history • OR bachelor's degree in history AND master's degree in political science, humanities, geography, area studies, women's studies, social science or ethnic studies • OR master's degree in humanities • OR the equivalent
MUS 100	<ul style="list-style-type: none"> • Master's degree in music • OR bachelor's degree in music AND master's degree in humanities • OR the equivalent
PROD 301	<ul style="list-style-type: none"> • Master's degree in counseling, rehabilitation counseling, clinical psychology, counseling psychology, guidance counseling, educational counseling, social work, career development, marriage and family therapy, or marriage, family, and child counseling • OR the equivalent <p>NOTE: A bachelor's degree in one of the listed degrees and a license as a Marriage and Family Therapist (MFT) is an alternative qualification for this discipline</p> <ul style="list-style-type: none"> • OR master's degree in education • OR any bachelor's degree or higher and two years of professional experience in Office Technologies • OR any associate degree and six years of professional experience in Office Technologies. <p>NOTE: Professional experience is required when the application possesses a master's degree.</p>

	The professional experience required must be directly related to the teaching assignment.
PSYC C1000 PSY 117 PSY 118	<ul style="list-style-type: none"> • Master's degree in psychology • OR bachelor's degree in psychology AND master's degree in counseling, sociology, statistics, neuroscience or social work • OR the equivalent
SOC 101	<ul style="list-style-type: none"> • Master's degree in sociology • OR bachelor's degree in sociology AND master's degree in anthropology, any ethnic studies, social work, or psychology • OR the equivalent
WEE 149 WEE 382	<ul style="list-style-type: none"> • The minimum qualifications in any discipline in which work experience may be provided
WLDT 106 WLDT 300	<ul style="list-style-type: none"> • Any bachelor's degree or higher and two years of professional experience • OR any associate degree and six years of professional experience. <p>NOTE: Professional experience is required when the application possesses a master's degree. The professional experience required must be directly related to the teaching assignment.</p>

3. **BOOKS AND INSTRUCTIONAL MATERIALS:** The total cost of books and instructional materials for SCHOOL DISTRICT students participating in CCAP course as part of this CCAP Agreement will be borne by SCHOOL DISTRICT. Current pricing and textbook availability is published on the COLLEGE bookstore website each semester.
4. **JOINT FACILITIES USE PROTOCOLS:** COLLEGE and SCHOOL DISTRICT shall adhere to the terms and protocols outlined in Section 19, Facilities, of the CCAP Agreement. SCHOOL DISTRICT, shall extend access and use of the following SCHOOL DISTRICT facilities:

BUILDING NAME & ADDRESS	CLASSROOM	DAYS	HOURS
Ernest Righetti High School 941 E. Foster Rd. Santa Maria, CA 93455	Various, TBD	Monday through Friday	8:30 am – 8:00 pm

Guadalupe Senior Center 4545 10 th Street., Guadalupe, Ca 93434	Multipurpose room & Classroom	Monday through Friday	4:00 pm – 8:00 pm
--	----------------------------------	-----------------------	-------------------

ALLAN HANCOCK JOINT COMMUNITY COLLEGE
 DISTRICT

ERNEST RIGHETTI HIGH SCHOOL

By: _____
 Vice-President, Academic Affairs

Date: _____

By: _____
 Vice-President, Finance & Administration

Date: _____

By: 
 Principal

Date: 5/15/25

By: 
 Head Counselor

Date: 5/15/25

APPENDIX C

CCAP Agreement Courses Approved for 2025 - 2026

HIGH SCHOOL DISTRICT: Santa Maria Joint Union High School District

HIGH SCHOOL SITE: Pioneer Valley High School

PROJECTED NUMBER OF STUDENTS TO BE SERVED: 1,970

TOTAL PROJECTED FTES: 265.78

CCAP Pathway	College Degree or Certificate	High School Pathway	CCAP Course Offerings		Number of Sections, High School period(s) & Times		Instructor Name & Employer of Record (AHC or HS)		Projected Number of Students	Projected FTES
			FALL	SPRING	FALL	SPRING	FALL	SPRING		
Career Technical Education	Agricultural Science - AS	Ag Business	AG4004 (HS)	AG 158	2 Times & Periods TBD	2 Times & Periods TBD	Marcie Guerra (HS)	Marcie Guerra (HS)	72	7.41
Career Technical Education	Agricultural Science - AS	Ag Business	AG66740 (HS)	AG 150	1 Times & Periods TBD	1 Times & Periods TBD	Marcie Guerra (HS)	Marcie Guerra (HS)	36	3.70
Career Technical Education	Agricultural Science - AS	Animal Science	AG6278 (HS)	AG 152	1 Times & Periods TBD	1 Times & Periods TBD	Gabriel Ponce (HS)	Gabriel Ponce (HS)	36	3.70
Career Technical Education	Agricultural Science - AS	Ag Business	AG6292	AG 157	1 Times & Periods TBD	1 Times & Periods TBD	Gabriel Ponce (HS)	Gabriel Ponce (HS)	36	3.70
Career Technical Education	Agricultural Science - AS	AG Mechanics	AG6680 (HS)	AG 155	1 Times & Periods TBD	1 Times & Periods TBD	Hector Guerra (HS)	Hector Guerra (HS)	36	3.70
Career Technical Education	Agricultural Science - AS	High School Elective Courses	AG 154	AG 156	1 Times & Periods TBD	1 Times & Periods TBD	Hector Guerra (HS)	Hector Guerra (HS)	36	7.40

Career Technical Education	Sports Medicine - AS	Patient Care	SC3000 (HS)	ATH 104		1 Times & Periods TBD	1 Times & Periods TBD	Hallie Smith (HS)	Hallie Smith (HS)	36	4.94
Career Technical Education	Fashion Studies - AS	Fashion Design & Manufacturing	HE6254 (HS)	FASH 110		3 Times & Periods TBD	3 Times & Periods TBD	Melissa Diaz	TBD (AHC)	78	16.05
Career Technical Education	Administration of Justice - AS	High School Elective	AJ 101	AJ 103		1 Times & Periods TBD	1 Times & Periods TBD	TBD (AHC)	TBD (AHC)	20	4.12
Preparation for Transfer	AA-T Cal-GETC	HS Graduation Requirement	EN3223 (HS)	ENGL C1000		3 Times & Periods TBD	3 Times & Periods TBD	Benjamin Rothstein (HS)	Benjamin Rothstein (HS)	108	14.81
Preparation for Transfer	AA-T Cal-GETC	HS Graduation Requirement	EN4013 (HS)	ENGL C1001		2 Times & Periods TBD	2 Times & Periods TBD	Miles Brown (HS)	Miles Brown (HS)	72	7.41
Preparation for Transfer	AA-T Cal-GETC	HS Graduation Requirement	EN4013 (HS)	ENGL C1001		1 Times & Periods TBD	1 Times & Periods TBD	Shannon O'Neal (HS)	Shannon O'Neal (HS)	36	3.70
Preparation for Transfer	AA-T Cal-GETC	HS Graduation Requirement	POLS (HS)	POLS C1000		1 Times & Periods TBD	1 Times & Periods TBD	Glenn Fairchild (HS)	Glenn Fairchild (HS)	72	7.41
Preparation for Transfer	AA-T Cal-GETC	HS Graduation Requirement	MATH 131	MATH 121		2 Times & Periods TBD	2 Times & Periods TBD	Brooke Baarstad (HS)	Brooke Baarstad (HS)	72	17.25
Preparation for Transfer	AA-T Cal-GETC	HS Graduation Requirement	MA6082 (HS)	STAT C1000		1 Times & Periods TBD	1 Times & Periods TBD	Brooke Baarstad (HS)	Brooke Baarstad (HS)	36	6.17
Preparation for Transfer	AA-T Cal-GETC	HS Graduation Requirement	HIST 101	HIST 102		3 Times & Periods TBD	3 Times & Periods TBD	Glenn Fairchild (HS)	Glenn Fairchild (HS)	108	11.11
Preparation for Transfer	AA-T Cal-GETC	HS Graduation Requirement	HIST 107	HIST 108		3 Times & Periods TBD	3 Times & Periods TBD	Brett Dodson (HS)	Brett Dodson (HS)	108	11.11

Preparation for Transfer	AA-T Cal-GETC	HS Graduation Requirement	FRCH 101	FRCH 102	3 Times & Periods TBD	1 Times & Periods TBD	Alicia Ekberg (HS)	108/36	24.68
College & Career Readiness	AA GE	College/Career Readiness	PROD 301 HS course	HS course PROD 301	3 Times & Periods TBD	3 Times & Periods TBD	Cristian Cardenas (HS)	216 cohorts rotate	22.22
College & Career Readiness	AA GE	College/Career Readiness	PROD 301 HS course	HS course PROD 301	1 Times & Periods TBD	1 Times & Periods TBD	Megan Martinez (HS)	72 cohorts rotate	7.41
College & Career Readiness	AA GE	College/Career Readiness	PROD 301 HS course	HS course PROD 301	1 Times & Periods TBD	1 Times & Periods TBD	Rachel McClean (HS)	72 cohorts rotate	7.41
College & Career Readiness	AA GE	College/Career Readiness	PROD 301 HS course	HS course PROD 301	2 Times & Periods TBD	2 Times & Periods TBD	Denise Ortiz (HS)	144 cohorts rotate	14.81
College & Career Readiness	AA GE	College/Career Readiness	PROD 301 HS course	HS course PROD 301	5 Times & Periods TBD	5 Times & Periods TBD	Cody Smit (HS)	360 cohorts rotate	37.03

1. **Required:** Describe the criteria used to assess the ability of pupils to benefit from the course(s) offered:

In consultation with their SCHOOL DISTRICT counselors, students self-select a pathway based on their academic readiness and alignment of course content to students' educational and career goals. SCHOOL DISTRICT and COLLEGE faculty identified CCAP courses using the following criteria:

- Alignment with HIGH SCHOOL pathways and COLLEGE programs of study.
- Potential for course completion to accelerate students' time to completion of postsecondary degree or certificate.

- c. Potential to earn a Certificate of Training and be eligible to enter the workforce in their selected career technical pathway.
 - d. Potential to work toward completion of an associate degree or an associate degree for transfer.
2. **MINIMUM QUALIFICATIONS FOR INSTRUCTION:** All instructors teaching CCAP Agreement Courses must meet the minimum qualifications for instruction in a California community college as set forth in Title 5 of the California Code of Regulations, sections 53410 and 58060 or as amended. The minimum qualifications for instruction are:

Course Name & Number	Minimum Qualifications For Instructors
AG 150	<ul style="list-style-type: none"> • Any bachelor’s degree or higher and two years of professional experience • OR any associate degree and six years of professional experience <p>NOTE: Professional experience is required when the application possesses a master’s degree. The professional experience required must be directly related to the teaching assignment.</p> <ul style="list-style-type: none"> • OR master’s degree in agriculture, agricultural science, education with a specialization in agriculture or other agricultural area, including agricultural business, agricultural engineering, agricultural mechanics, agronomy, animal science, enology, environmental (ornamental) horticulture, equine science, forestry, natural resources, plant science, pomology, soil science, viticulture or other agriculture science • OR master’s degree in business, business management, business administration, accountancy, finance, marketing or business education • OR bachelor’s degree in any of the above AND master’s degree in economics, personnel management, public administration, or Juris Doctor Degree (J.D.) or Legum Baccalaureus (LL.B.) • OR bachelor’s degree in economics with a business emphasis AND master’s in personnel management, public administration, or Juris Doctor Degree (J.D.) or Legum Baccalaureus (LL.B.) • OR master’s degree in business administration, business management, business education, marketing, advertising or finance • OR bachelor’s degree in any of the above AND master’s degree in economics, accountancy, taxation or law • OR the equivalent
AG 152 AG 154 AG 155	<ul style="list-style-type: none"> • Any bachelor’s degree or higher and two years of professional experience • OR any associate degree and six years of professional experience. <p>Professional experience is required when the application possesses a master’s degree. The professional experience required must be directly related to the teaching assignment.</p>

AG 156	<ul style="list-style-type: none"> • OR a master's degree in agriculture, agricultural science, education with a specialization in agriculture or other agricultural area, including agricultural business, agricultural engineering, agricultural mechanics, agronomy, animal science, enology, environmental (ornamental) horticulture, equine science, forestry, natural resources, plant science, pomology, soil science, viticulture or other agriculture science • OR the equivalent
AG 157	<ul style="list-style-type: none"> • Any bachelor's degree or higher and two years of professional experience • OR any associate degree and six years of professional experience. <p>NOTE: Professional experience is required when the application possesses a master's degree. The professional experience required must be directly related to the teaching assignment</p> <ul style="list-style-type: none"> • OR a master's degree in agriculture, agricultural science, education with a specialization in agriculture or other agricultural area, including agricultural business, agricultural engineering, agricultural mechanics, agronomy, animal science, enology, environmental (ornamental) horticulture, equine science, forestry, natural resources, plant science, pomology, soil science, viticulture or other agriculture science • OR master's degree in business, business management, business administration, accountancy, finance, marketing or business education • OR bachelor's degree in any of the above AND master's degree in economics, personnel management, public administration, or Juris Doctor Degree (J.D.) or Legum Baccalaureus (LL.B.) OR bachelor's degree in economics with a business emphasis AND master's in personnel management, public administration, or Juris Doctor Degree (J.D.) or Legum Baccalaureus (LL.B.) • OR the equivalent
AG 158	<ul style="list-style-type: none"> • Master's degree in agriculture, agricultural science, education with a specialization in agriculture or other agricultural area, including agricultural business, agricultural engineering, agricultural mechanics, agronomy, animal science, enology, environmental (ornamental) horticulture, equine science, forestry, natural resources, plant science, pomology, soil science, viticulture or other agriculture science • OR the equivalent
AJ 101 AJ 103	<ul style="list-style-type: none"> • Any bachelor's degree or higher and two years of professional experience • OR any associate degree and six years of professional experience. <p>NOTE: Professional experience is required when the application possesses a master's degree. The professional experience required must be directly related to the teaching assignment.</p>

ATH 104	<ul style="list-style-type: none"> • Any bachelor's degree or higher and two years of professional experience • OR any associate degree and six years of professional experience. <p>NOTE: Professional experience is required when the application possesses a master's degree. The professional experience required must be directly related to the teaching assignment.</p>
ENGL C1000 ENGL C1001	<ul style="list-style-type: none"> • Master's degree in English, literature, comparative literature, or composition • OR bachelor's degree in any of the above AND master's degree in linguistics, TESL, speech, or education with a specialization in reading, creative writing or journalism • OR the equivalent
FASH 110	<ul style="list-style-type: none"> • Any bachelor's degree or higher and two years of professional experience • OR any associate degree and six years of professional experience. <p>NOTE: Professional experience is required when the application possesses a master's degree. The professional experience required must be directly related to the teaching assignment.</p>
HIST 101 HIST 102 HIST 107 HIST 108	<ul style="list-style-type: none"> • Master's degree in history • OR bachelor's degree in history AND master's degree in political science, humanities, geography, area studies, women's studies, social science or ethnic studies • OR the equivalent
MATH 121 MATH 131 STAT C1000	<ul style="list-style-type: none"> • Master's degree in mathematics or applied mathematics • OR bachelor's degree in either of the above AND master's degree in statistics, physics or mathematics education • OR the equivalent
POLS C1000	<ul style="list-style-type: none"> • Master's degree in political science, government, or international relations • OR bachelor's degree in any of the above AND master's degree in economics, history, public administration, social science, sociology, and any ethnic studies, Juris Doctor Degree (J.D.) or Legum Baccalaureus (LL.B.) • OR the equivalent
PROD 301	<ul style="list-style-type: none"> • Master's degree in counseling, rehabilitation counseling, clinical psychology, counseling psychology, guidance counseling, educational counseling, social work, career development, marriage and family therapy, or marriage, family, and child counseling • OR the equivalent <p>NOTE: A bachelor's degree in one of the listed degrees and a license as a Marriage and Family</p>

	<p>Therapist (MFT) is an alternative qualification for this discipline</p> <ul style="list-style-type: none"> • OR master's degree in education • OR any bachelor's degree or higher and two years of professional experience in Office Technologies • OR any associate degree and six years of professional experience in Office Technologies. <p>NOTE: Professional experience is required when the application possesses a master's degree. The professional experience required must be directly related to the teaching assignment.</p>
--	---

3. **BOOKS AND INSTRUCTIONAL MATERIALS:** The total cost of books and instructional materials for SCHOOL DISTRICT students participating in CCAP course as part of this CCAP Agreement will be borne by SCHOOL DISTRICT. Current pricing and textbook availability is published on the COLLEGE bookstore website each semester.

4. **JOINT FACILITIES USE PROTOCOLS:** COLLEGE and SCHOOL DISTRICT shall adhere to the terms and protocols outlined in Section 19, Facilities, of the CCAP Agreement. SCHOOL DISTRICT, shall extend access and use of the following SCHOOL DISTRICT facilities:

BUILDING NAME & ADDRESS	CLASSROOM	DAYS	HOURS
Pioneer Valley High School 675 Panther Drive Santa Maria, CA 93454	TBD	Monday through Friday	8:30 am – 4:00 pm
Pioneer Valley High School 675 Panther Drive Santa Maria, CA 93454	553, 554	Monday	4:00 pm – 6:00 pm

ALLAN HANCOCK JOINT COMMUNITY COLLEGE
DISTRICT

By: _____
Vice-President, Academic Affairs

Date: _____

PIONEER VALLEY HIGH SCHOOL

By:  _____
Principal

Date: _____
By:  _____
Head Counselor

Date: 5/22/25

* Courses offered outside of high school bell schedule (zero period or after school)

APPENDIX C

CCAP Agreement Courses Approved for 2025 - 2026

HIGH SCHOOL DISTRICT: Santa Maria Joint Union High School District

HIGH SCHOOL SITE: Santa Maria High School

PROJECTED NUMBER OF STUDENTS TO BE SERVED: 1,476

TOTAL PROJECTED FTES: 208.59

CCAP Pathway	College Degree or Certificate	High School Pathway	CCAP Course Offerings		Number of Sections, High School period(s) & Times		Instructor Name & Employer of Record (AHC or HS)		Projected Number of Students	Projected FTES
			FALL	SPRING	FALL	SPRING	FALL	SPRING		
Career Technical Education	Agricultural Science - AS	TBD	AG 152	AG 156	1 Times & Periods TBD	1 Times & Periods TBD	Clemente Ayon (HS)	Marc DeBernardi (HS)	36	7.41
Career Technical Education	Agricultural Science - AS	TBD	AG 155	AG 158	1 Times & Periods TBD	1 Times & Periods TBD	Luis Guerra (HS)	Melissa Flory (HS)	36	7.41
Preparation for Transfer	Administration of Justice - AA	TBD	AJ 101	AJ 103	1 Times & Periods TBD	1 Times & Periods TBD	TBD (AHC)	TBD (AHC)	36	7.41
Career Technical Education	Welding Technology - CA	TBD	WLDT 300	WLDT 106	1 Times & Periods TBD	1 Times & Periods TBD	Luis Guerra (HS)	Luis Guerra (HS)	36	14.82
Preparation for Transfer	AA-T Cal-GETC	TBD	ENGL C1001	ENGL C1001	2 Times & Periods TBD	2 Times & Periods TBD	TBD (HS)	TBD (HS)	72	17.28

Preparation for Transfer	AA-T Cal-GETC	TBD	FRCH 101	FRCH 102	2 Times & Periods TBD	2 Times & Periods TBD	Meena Akhavan (HS)	Meena Akhavan (HS)	72	24.68
Preparation for Transfer	AA-T Cal-GETC	TBD	ECON (HS)	POLS C1000	2 Times & Periods TBD	2 Times & Periods TBD	TBD (HS)	Richard Guiremand (HS)	72	7.41
Preparation for Transfer	AA-T Cal-GETC	TBD	Physics (HS)	PHYS 100	1 Times & Periods TBD	1 Times & Periods TBD	TBD (HS)	Ben Wisman	36	3.70
Preparation for Transfer	AA-T Cal-GETC	TBD	MATH 131	MATH 121	1 Times & Periods TBD	1 Times & Periods TBD	TBD (HS)	TBD (HS)	36	8.64
Preparation for Transfer	AA-T Cal-GETC	TBD	Math (HS)	STAT C1000	1 Times & Periods TBD	1 Times & Periods TBD	TBD (HS)	TBD (HS)	36	6.17
Preparation for Transfer	AA-T Cal-GETC	TBD	HIST 107	HIST 108	3 Times & Periods TBD	3 Times & Periods TBD	Amy Hennings (HS)	Amy Hennings (HS)	108	22.22
Preparation for Transfer	AA-T Cal-GETC	TBD	TBD	SOC 101	1 Times & Periods TBD	1 Times & Periods TBD	TBD (AHC)	TBD (AHC)	36	3.70
Preparation for Transfer	AA-T Cal-GETC	TBD	AJ 101	AJ 103	1 Times & Periods TBD	1 Times & Periods TBD	TBD (AHC)	TBD (AHC)	36	7.41
College & Career Readiness	AA GE	TBD	PROD 301	PROD 301	10 Times & Periods TBD	10 Times & Periods TBD	David Yamate (HS) Rick Hebert (HS)	David Yamate (HS) Rick Hebert (HS)	720 cohorts rotate	74.06

1. **Required:** Describe the criteria used to assess the ability of pupils to benefit from the course(s) offered:

In consultation with their SCHOOL DISTRICT counselors, students self-select a pathway based on their academic readiness and alignment of course content to students' educational and career goals. SCHOOL DISTRICT and COLLEGE faculty identified CCAP courses using the following criteria:

- a. Alignment with HIGH SCHOOL pathways and COLLEGE programs of study.
- b. Potential for course completion to accelerate students' time to completion of postsecondary degree or certificate.
- c. Potential to earn a Certificate of Training and be eligible to enter the workforce in their selected career technical pathway.
- d. Potential to work toward completion of an associate degree or an associate degree for transfer.

2. **MINIMUM QUALIFICATIONS FOR INSTRUCTION:** All instructors teaching CCAP Agreement Courses must meet the minimum qualifications for instruction in a California community college as set forth in Title 5 of the California Code of Regulations, sections 53410 and 58060 or as amended. The minimum qualifications for instruction are:

Course Name & Number	Minimum Qualifications For Instructors
AG 150	<ul style="list-style-type: none"> • Any bachelor's degree or higher and two years of professional experience • OR any associate degree and six years of professional experience <p>NOTE: Professional experience is required when the application possesses a master's degree. The professional experience required must be directly related to the teaching assignment.</p> <ul style="list-style-type: none"> • OR master's degree in agriculture, agricultural science, education with a specialization in agriculture or other agricultural area, including agricultural business, agricultural engineering, agricultural mechanics, agronomy, animal science, enology, environmental (ornamental) horticulture, equine science, forestry, natural resources, plant science, pomology, soil science, viticulture or other agriculture science • OR master's degree in business, business management, business administration, accountancy, finance, marketing or business education • OR bachelor's degree in any of the above AND master's degree in economics, personnel management, public administration, or Juris Doctor Degree (J.D.) or Legum Baccalaureus (LL.B.) • OR bachelor's degree in economics with a business emphasis AND master's in personnel management, public administration, or Juris Doctor Degree (J.D.) or Legum Baccalaureus (LL.B.) • OR master's degree in business administration, business management, business education, marketing, advertising or finance • OR bachelor's degree in any of the above AND master's degree in economics, accountancy, taxation or law • OR the equivalent
AG 100 AG 152	<ul style="list-style-type: none"> • Any bachelor's degree or higher and two years of professional experience • OR any associate degree and six years of professional experience.

AG 153	<p>Professional experience is required when the application possesses a master's degree. The professional experience required must be directly related to the teaching assignment.</p> <ul style="list-style-type: none"> OR a master's degree in agriculture, agricultural science, education with a specialization in agriculture or other agricultural area, including agricultural business, agricultural engineering, agricultural mechanics, agronomy, animal science, enology, environmental (ornamental) horticulture, equine science, forestry, natural resources, plant science, pomology, soil science, viticulture or other agriculture science OR the equivalent
AG 157	<ul style="list-style-type: none"> Any bachelor's degree or higher and two years of professional experience OR any associate degree and six years of professional experience. <p>NOTE: Professional experience is required when the application possesses a master's degree. The professional experience required must be directly related to the teaching assignment</p> <ul style="list-style-type: none"> OR a master's degree in agriculture, agricultural science, education with a specialization in agriculture or other agricultural area, including agricultural business, agricultural engineering, agricultural mechanics, agronomy, animal science, enology, environmental (ornamental) horticulture, equine science, forestry, natural resources, plant science, pomology, soil science, viticulture or other agriculture science OR master's degree in business, business management, business administration, accountancy, finance, marketing or business education OR bachelor's degree in any of the above AND master's degree in economics, personnel management, public administration, or Juris Doctor Degree (J.D.) or Legum Baccalaureus (LL.B.) OR bachelor's degree in economics with a business emphasis AND master's in personnel management, public administration, or Juris Doctor Degree (J.D.) or Legum Baccalaureus (LL.B.) OR the equivalent
AG 158	<ul style="list-style-type: none"> Master's degree in agriculture, agricultural science, education with a specialization in agriculture or other agricultural area, including agricultural business, agricultural engineering, agricultural mechanics, agronomy, animal science, enology, environmental (ornamental) horticulture, equine science, forestry, natural resources, plant science, pomology, soil science, viticulture or other agriculture science OR the equivalent
AJ 101	<ul style="list-style-type: none"> Any bachelor's degree or higher and two years of professional experience OR any associate degree and six years of professional experience. <p>NOTE: Professional experience is required when the application possesses a master's degree. The professional experience required must be directly related to the teaching assignment.</p>
AJ 103	
AJ 105	

ART 101 ART 120	<ul style="list-style-type: none"> • Master's degree in fine arts, art, or art history • OR bachelor's degree in any of the above AND master's degree in humanities • OR the equivalent <p>NOTE: "master's degree in fine arts" as used here refers to any master's degree in the subject matter of fine arts, which is defined to include visual studio arts such as drawing, painting, sculpture, printmaking, ceramics, textiles, and metal and jewelry art, and also art education and art therapy. It does not refer to the "Master of Fine Arts" (MFA) degree when that degree is based on specialization in performing arts or dance, film, video, photography, creative writing or other nonplastic arts.</p>
ASL 120 ASL 121	<ul style="list-style-type: none"> • Master's degree in American Sign Language • OR bachelor's degree in American Sign Language AND master's degree in another language or linguistics • OR the equivalent
AT 100 AT 303 AT 313 AT 323	<ul style="list-style-type: none"> • Any bachelor's degree or higher and two years of professional experience • OR any associate degree and six years of professional experience. <p>NOTE: Professional experience is required when the application possesses a master's degree. The professional experience required must be directly related to the teaching assignment.</p>
ATH 104	<ul style="list-style-type: none"> • Any bachelor's degree or higher and two years of professional experience • OR any associate degree and six years of professional experience. <p>NOTE: Professional experience is required when the application possesses a master's degree. The professional experience required must be directly related to the teaching assignment.</p>
BIOL 100	<ul style="list-style-type: none"> • Master's degree in any biological science • OR bachelor's degree in any biological science AND master's degree in biochemistry, biophysics, or marine science • OR the equivalent
CA 119 CA 120 CA 124	<ul style="list-style-type: none"> • Any bachelor's degree or higher and two years of professional experience • OR any associate degree and six years of professional experience. <p>NOTE: Professional experience is required when the application possesses a master's degree. The professional experience required must be directly related to the teaching assignment.</p>
CNET 105	<ul style="list-style-type: none"> • Any bachelor's degree or higher and two years of professional experience

CNET 106 CNET 107	<ul style="list-style-type: none"> OR any associate degree and six years of professional experience. <p>NOTE: Professional experience is required when the application possesses a master's degree. The professional experience required must be directly related to the teaching assignment.</p>
COMM C1000	<ul style="list-style-type: none"> Master's degree in speech, speech broadcasting, telecommunications, rhetoric, communication, communication studies, speech communication or organizational communication OR bachelor's degree in any of the above AND master's degree in drama/theater arts, mass communication or English OR the equivalent
DANC 140	<ul style="list-style-type: none"> Master's degree in dance, physical education with a dance emphasis, or theater with dance emphasis OR bachelor's degree in any of the above AND master's degree in physical education, any life science, physiology, theater arts, kinesiology, humanities, performing arts or music OR any bachelor's degree or higher and two years of professional experience in Folk Dance OR any associate degree and six years of professional experience in Folk Dance. Professional experience is required when the application possesses a master's degree. The professional experience required must be directly related to the teaching assignment OR the equivalent
DANC 142	<ul style="list-style-type: none"> Master's degree in dance, physical education with a dance emphasis, or theater with dance emphasis OR bachelor's degree in any of the above AND master's degree in physical education, any life science, physiology, theater arts, kinesiology, humanities, performing arts or music OR the equivalent
DANC 145	<ul style="list-style-type: none"> Master's degree in dance, physical education with a dance emphasis, or theater with dance emphasis, with professional experience in Folklorico OR bachelor's degree in any of the above AND master's degree in physical education, any life science, physiology, theater arts, kinesiology, humanities, performing arts or music AND professional experience in Folklorico OR the equivalent
DRMA 103	<ul style="list-style-type: none"> Master's degree or Master's degree of Fine Arts in drama/theater arts/performance OR bachelor's degree or bachelor's degree of Fine Arts in drama/theater arts/performance AND master's degree in comparative literature, English, communication studies, speech, literature or humanities OR the equivalent

EMS 102	<ul style="list-style-type: none"> • Any bachelor's degree or higher and two years of professional experience • OR any associate degree and six years of professional experience. <p>NOTE: Professional experience is required when the application possesses a master's degree. The professional experience required must be directly related to the teaching assignment.</p>
ECS 100 ECS 101	<ul style="list-style-type: none"> • Master's degree in child development, early childhood education, human development, home economics/family and consumer studies with a specialization in child development/early childhood education or educational psychology with a specialization in child development/early childhood education • OR bachelor's degree in any of the above AND master's in social work, educational supervision, elementary education, special education, psychology, bilingual/bicultural education, life management/home economics, family life studies or family and consumer studies • OR the equivalent
EDUC 130	<ul style="list-style-type: none"> • Master's degree in education • OR the equivalent
EDUC 132	<ul style="list-style-type: none"> • Master's degree in child development, early childhood education, human development, home economics/family and consumer studies with a specialization in child development/early childhood education or educational psychology with a specialization in child development/early childhood education • OR bachelor's degree in any of the above AND master's in social work, educational supervision, elementary education, special education, psychology, bilingual/bicultural education, life management/home economics, family life studies or family and consumer studies • OR master's degree in education • OR the equivalent
EMS 102	<ul style="list-style-type: none"> • Any bachelor's degree or higher and two years of professional experience • OR any associate degree and six years of professional experience. <p>NOTE: Professional experience is required when the application possesses a master's degree. The professional experience required must be directly related to the teaching assignment.</p>
ENGL 100 ENGL C1000 ENGL 102	<ul style="list-style-type: none"> • Master's degree in English, literature, comparative literature, or composition • OR bachelor's degree in any of the above AND master's degree in linguistics, TESL, speech, or education with a specialization in reading, creative writing or journalism • OR the equivalent

ENGL C1001 ENGL 145 ENGL 146	
ES 120	<ul style="list-style-type: none"> • Master's degree in African American Studies, Black Studies, Africana Studies, Latino Studies, La Raza Studies, Chicana/o Studies, Asian American Studies, Native American Studies, or American Indian Studies • OR master's degree in Ethnic Studies • OR the equivalent
FILM 101 FILM 110	<ul style="list-style-type: none"> • Master's degree in film/cinema and media studies, film, television, and media studies, drama/theater, and mass communication • OR bachelor's degree in any of the above AND master's degree in visual studies, media studies, English, or communication • OR the equivalent
FRCH 101 FRCH 102	<ul style="list-style-type: none"> • Master's degree in French • OR bachelor's degree in French AND master's degree in another language or linguistics • OR the equivalent
GEOG 101 GEOG 102	<ul style="list-style-type: none"> • Master's degree in geography • OR bachelor's degree in geography AND master's degree in geology, history, meteorology or oceanography • OR the equivalent
GEO 100	<ul style="list-style-type: none"> • Master's degree in geology, geophysics, earth sciences, meteorology, oceanography or paleontology • OR bachelor's degree in geology AND master's degree in geography, physics, or geochemistry • OR the equivalent • OR master's degree in the interdisciplinary area • OR master's degree in one of the disciplines included in the interdisciplinary area and upper division or graduate course work in at least one other constituent discipline <p>NOTE: The Interdisciplinary Studies discipline is provided to allow for those cases where it is locally determined that a course must be taught by someone with qualifications that exceed a single discipline. The constituent disciplines can include any disciplines found in the Master's List.</p>

<p>GRPH 112 GRPH 113</p>	<ul style="list-style-type: none"> • Any bachelor's degree or higher and two years of professional experience • OR any associate degree and six years of professional experience. <p>NOTE: Professional experience is required when the application possesses a master's degree. The professional experience required must be directly related to the teaching assignment.</p>
<p>HIST 101 HIST 102 HIST 104 HIST 105 HIST 107 HIST 108</p>	<ul style="list-style-type: none"> • Master's degree in history • OR bachelor's degree in history AND master's degree in political science, humanities, geography, area studies, women's studies, social science or ethnic studies • OR the equivalent
<p>HIST 120</p>	<ul style="list-style-type: none"> • Master's degree in Chicano Studies • OR master's degree in African American Studies, Black Studies, Africana Studies, Latino Studies, La Raza Studies, Chicana/o Studies, Asian American Studies, Native American Studies, or American Indian Studies • OR master's degree in ethnic studies • OR master's degree in history • OR bachelor's degree in history AND master's degree in political science, humanities, geography, area studies, women's studies, social science or ethnic studies • OR master's degree in humanities • OR the equivalent
<p>HUSV 110</p>	<ul style="list-style-type: none"> • Any bachelor's degree or higher and two years of professional experience in Addiction Paraprofessional Training • OR any associate degree and six years of professional experience. <p>NOTE: Professional experience is required when the application possesses a master's degree. The professional experience required must be directly related to the teaching assignment.</p> <ul style="list-style-type: none"> • Master's degree in counseling, rehabilitation counseling, clinical psychology, counseling psychology, guidance counseling, educational counseling, social work, career development, marriage and family therapy, or marriage, family and child counseling • NOTE: A bachelor's degree in one of the listed degrees and a license as a Marriage and Family Therapist (MFT) is an alternative qualification for this discipline

	<ul style="list-style-type: none"> • OR master's degree in education • OR the equivalent
<p>MA 305</p>	<ul style="list-style-type: none"> • Any bachelor's degree or higher and two years of professional experience • OR any associate degree and six years of professional experience. <p>NOTE: Professional experience is required when the application possesses a master's degree. The professional experience required must be directly related to the teaching assignment.</p>
<p>MATH 121 MATH 131 MATH 181 MATH 182 STAT C1000</p>	<ul style="list-style-type: none"> • Master's degree in mathematics or applied mathematics • OR bachelor's degree in either of the above AND master's degree in statistics, physics or mathematics education • OR the equivalent
<p>MMAC 126</p>	<ul style="list-style-type: none"> • Master's degree in fine arts, art, or art history • OR bachelor's degree in any of the above AND master's degree in humanities <p>NOTE: "master's degree in fine arts" as used here refers to any master's degree in the subject matter of fine arts, which is defined to include visual studio arts such as drawing, painting, sculpture, printmaking, ceramics, textiles, and metal and jewelry art, and also art education and art therapy. It does not refer to the "Master of Fine Arts" (MFA) degree when that degree is based on specialization in performing arts or dance, film, video, photography, creative writing, or other non-plastic arts.)</p> <ul style="list-style-type: none"> • OR master's degree in film/cinema and media studies, film, television, and media studies, drama/theater, mass communication • OR bachelor's degree in any of the above AND master's degree in visual studies, media studies, English, or communication • OR the equivalent • OR Any bachelor's degree or higher and two years of professional experience • OR any associate degree and six years of professional experience. <p>NOTE: Professional experience is required when the application possesses a master's degree. The professional experience required must be directly related to the teaching assignment</p>
<p>MUS 100</p>	<ul style="list-style-type: none"> • Master's degree in music • OR bachelor's degree in music AND master's degree in humanities • OR the equivalent

MT 109 MT 113 MT 116	<ul style="list-style-type: none"> • Any bachelor's degree or higher and two years of professional experience • OR any associate degree and six years of professional experience. <p>NOTE: Professional experience is required when the application possesses a master's degree. The professional experience required must be directly related to the teaching assignment.</p>
PD 101	<ul style="list-style-type: none"> • Master's degree in counseling, rehabilitation counseling, clinical psychology, counseling psychology, guidance counseling, educational counseling, social work, career development, marriage and family therapy, or marriage, family and child counseling • NOTE: A bachelor's degree in one of the listed degrees and a license as a Marriage and Family Therapist (MFT) is an alternative qualification for this discipline • OR master's degree in education • OR the equivalent
PHYS 100	<ul style="list-style-type: none"> • Master's degree in physics, astronomy or astrophysics • OR bachelor's degree in physics or astronomy AND master's degree in engineering, mathematics, meteorology or geophysics • OR the equivalent
POLS C1000	<ul style="list-style-type: none"> • Master's degree in political science, government, or international relations • OR bachelor's degree in any of the above AND master's degree in economics, history, public administration, social science, sociology, and any ethnic studies, Juris Doctor Degree (J.D.) or Legum Baccalaureus (LL.B.) • OR the equivalent
PROD 301	<ul style="list-style-type: none"> • Master's degree in counseling, rehabilitation counseling, clinical psychology, counseling psychology, guidance counseling, educational counseling, social work, career development, marriage and family therapy, or marriage, family, and child counseling • OR the equivalent <p>NOTE: A bachelor's degree in one of the listed degrees and a license as a Marriage and Family Therapist (MFT) is an alternative qualification for this discipline</p> <ul style="list-style-type: none"> • OR master's degree in education • OR any bachelor's degree or higher and two years of professional experience in Office Technologies • OR any associate degree and six years of professional experience in Office Technologies. <p>NOTE: Professional experience is required when the application possesses a master's degree. The professional experience required must be directly related to the teaching assignment.</p>
PSYC C1000	<ul style="list-style-type: none"> • Master's degree in psychology • OR bachelor's degree in psychology AND master's degree in counseling, sociology,

	<ul style="list-style-type: none"> statistics, neuroscience or social work OR the equivalent
SOC 101	<ul style="list-style-type: none"> Master's degree in sociology OR bachelor's degree in sociology AND master's degree in anthropology, any ethnic studies, social work, or psychology OR the equivalent
SPAN 101 SPAN 102	<ul style="list-style-type: none"> Master's degree in Spanish OR bachelor's degree in Spanish AND master's degree in another language or linguistics OR the equivalent
SPCH 101	<ul style="list-style-type: none"> Master's degree in speech, speech broadcasting, telecommunications, rhetoric, communication, communication studies, speech communication or organizational communication OR bachelor's in any of the above AND master's degree in drama/theater arts, mass communication or English OR the equivalent
VEN 120	<ul style="list-style-type: none"> Any bachelor's degree or higher and two years of professional experience OR any associate degree and six years of professional experience. Professional experience is required when the application possesses a master's degree. The professional experience required must be directly related to the teaching assignment. OR a master's degree in agriculture, agricultural science, education with a specialization in agriculture or other agricultural area, including agricultural business, agricultural engineering, agricultural mechanics, agronomy, animal science, enology, environmental (ornamental) horticulture, equine science, forestry, natural resources, plant science, pomology, soil science, viticulture or other agriculture science OR the equivalent
WEE 149	<ul style="list-style-type: none"> The minimum qualifications in any discipline in which work experience may be provided
WLDT 106 WLDT 300	<ul style="list-style-type: none"> Any bachelor's degree or higher and two years of professional experience OR any associate degree and six years of professional experience. <p>NOTE: Professional experience is required when the application possesses a master's degree. The professional experience required must be directly related to the teaching assignment.</p>

3. **BOOKS AND INSTRUCTIONAL MATERIALS:** The total cost of books and instructional materials for

SCHOOLDISTRICT students participating in CCAP course as part of this CCAP Agreement will be borne by SCHOOLDISTRICT. Current pricing and textbook availability is published on the COLLEGE bookstore website each semester.

4. **JOINT FACILITIES USE PROTOCOLS:** COLLEGE and SCHOOL DISTRICT shall adhere to the terms and protocols outlined in Section 19, Facilities, of the CCAP Agreement. SCHOOL DISTRICT, shall extend access and use of the following SCHOOL DISTRICT facilities:

BUILDING NAME & ADDRESS	CLASSROOM	DAYS	HOURS
Santa Maria High School 901 South Broadway Santa Maria, CA 93454	TBD	Monday through Friday	8:30 am – 4:30 pm

ALLAN HANCOCK JOINT COMMUNITY COLLEGE SANTA MARIA HIGH SCHOOL
DISTRICT

By: _____
Vice-President, Academic Affairs

By: _____
Principal

Date: _____

Date: _____

By: _____
Vice-President, Finance & Administration

By: _____
Head Counselor

Date: _____

Date: _____

APPENDIX C

CCAP Agreement Courses Approved for 2025 - 2026

HIGH SCHOOL DISTRICT: Santa Maria Joint Union High School District

HIGH SCHOOL SITE: Mark Richardson CTE Center and AG Farm

PROJECTED NUMBER OF STUDENTS TO BE SERVED: 574

TOTAL PROJECTED FTES: 260.98

CCAP Pathway	College Degree or Certificate	High School Pathway	CCAP Course Offerings		Number of Sections, High School period(s) & Times		Instructor Name & Employer of Record (AHC or HS)		Projected Number of Students	Projected FTES
			FALL	SPRING	FALL	SPRING	FALL	SPRING		
Career Technical Education	Agricultural Science - AS	Plant and Soil Science	AG 153	AG 191	6	6	Steven Gambрил (HS)	Steven Gambрил (HS)	102	38.47
			AG 190		Period 1-2 8:30 am – 10:10 am	Period 1-2 8:30 am – 10:10 am				
Career Technical Education	Auto Tech: Auto Engine Rebuilding - AS	System Diagnostic, Service, and Repair		WEE 149*	3	3		Steven Gambрил (AHC)	102	48.96
			AT 100	AT 303	Period 1-2 8:30 am – 10:10 am	Period 1-2 8:30 am – 10:10 am	Eduardo Gonzales-Ramos (HS)	Eduardo Gonzales-Ramos (HS)		
					Period 3-4 10:45 am– 12:25 pm	Period 3-4 10:45 am– 12:25 pm				
					Period 5-6 1:05 pm – 2:45 pm	Period 5-6 1:05 pm – 2:45 pm				
					TBD	TBD				
					Period 3-4 10:45 am– 12:25 pm	Period 3-4 10:45 am– 12:25 pm				
					Period 5-6 1:05 pm – 2:45 pm	Period 5-6 1:05 pm – 2:45 pm				

Career Technical Education	Admin of Justice: Cyber Security - CA	AJ 160	AJ 162	1 TBD	1 TBD	TBD (AHC)	TBD (AHC)	20	4.11
----------------------------	---------------------------------------	--------	--------	----------	----------	-----------	-----------	----	------

1. **Required:** Describe the criteria used to assess the ability of pupils to benefit from the course(s) offered:

In consultation with their SCHOOL DISTRICT counselors, students self-select a pathway based on their academic readiness and alignment of course content to students' educational and career goals. SCHOOL DISTRICT and COLLEGE faculty identified CCAP courses using the following criteria:

- a. Alignment with HIGH SCHOOL pathways and COLLEGE programs of study.
- b. Potential for course completion to accelerate students' time to completion of postsecondary degree or certificate.
- c. Potential to earn a Certificate of Training and be eligible to enter the workforce in their selected career technical pathway.
- d. Potential to work toward completion of an associate degree or an associate degree for transfer.

2. **MINIMUM QUALIFICATIONS FOR INSTRUCTION:** All instructors teaching CCAP Agreement Courses must meet the minimum qualifications for instruction in a California community college as set forth in Title 5 of the California Code of Regulations, sections 53410 and 58060 or as amended. The minimum qualifications for instruction are:

Course Name & Number	Minimum Qualifications For Instructors
AG 153 AG 190 AG 191	<ul style="list-style-type: none"> • Any bachelor's degree or higher and two years of professional experience • OR any associate degree and six years of professional experience. Professional experience is required when the application possesses a master's degree. The professional experience required must be directly related to the teaching assignment. • OR a master's degree in agriculture, agricultural science, education with a specialization in agriculture or other agricultural area, including agricultural business, agricultural engineering, agricultural mechanics, agronomy, animal science, enology, environmental (ornamental) horticulture, equine science, forestry, natural resources, plant science, pomology, soil science, viticulture or other agriculture science • OR the equivalent
AJ 160 AJ 162	<ul style="list-style-type: none"> • Any bachelor's degree or higher and two years of professional experience • OR any associate degree and six years of professional experience. <p>NOTE: Professional experience is required when the application possesses a master's degree. The professional experience required must be directly related to the teaching assignment.</p>

AT 100 AT 303	<ul style="list-style-type: none"> Any bachelor's degree or higher and two years of professional experience OR any associate degree and six years of professional experience. <p>NOTE: Professional experience is required when the application possesses a master's degree. The professional experience required must be directly related to the teaching assignment.</p>
CA 119 CA 120 CA 124	<ul style="list-style-type: none"> Any bachelor's degree or higher and two years of professional experience OR any associate degree and six years of professional experience. <p>NOTE: Professional experience is required when the application possesses a master's degree. The professional experience required must be directly related to the teaching assignment.</p>
CNET 105 CNET 106 CNET 107	<ul style="list-style-type: none"> Any bachelor's degree or higher and two years of professional experience OR any associate degree and six years of professional experience. <p>NOTE: Professional experience is required when the application possesses a master's degree. The professional experience required must be directly related to the teaching assignment.</p>
MT 109 MT 113 MT 116	<ul style="list-style-type: none"> Any bachelor's degree or higher and two years of professional experience OR any associate degree and six years of professional experience. <p>NOTE: Professional experience is required when the application possesses a master's degree. The professional experience required must be directly related to the teaching assignment.</p>
WEE 149	<ul style="list-style-type: none"> The minimum qualifications in any discipline in which work experience may be provided

- BOOKS AND INSTRUCTIONAL MATERIALS:** The total cost of books and instructional materials for SCHOOL DISTRICT students participating in CCAP course as part of this CCAP Agreement will be borne by SCHOOL DISTRICT. Current pricing and textbook availability is published on the COLLEGE bookstore website each semester.
- JOINT FACILITIES USE PROTOCOLS:** COLLEGE and SCHOOL DISTRICT shall adhere to the terms and protocols outlined in Section 19, Facilities, of the CCAP Agreement. SCHOOL DISTRICT, shall extend access and use of the following SCHOOL DISTRICT facilities:

BUILDING NAME & ADDRESS	CLASSROOM	DAYS	HOURS
Mark Richardson CTE Center and AG Farm 1280 Founders Avenue Santa Maria, CA 93455	102, 103, 202, 204, 302, 304	Monday through Friday	8:30am – 8:30pm

ALLAN HANCOCK JOINT COMMUNITY COLLEGE DISTRICT

MARK RICHARDSON CTE CENTER & AG FARM

By: _____
Vice-President, Academic Affairs

Date: _____

By: _____
Principal

Date: _____

By: _____
Head Counselor

Date: _____

APPENDIX D Registration Timeline 2025 - 2026

2025-2026 Week Ranges	Process	Timeline	Type
Week 1: July 1, 2025 - July 7, 2025			
Week 2: July 8, 2025 - July 14, 2025			
Week 3: July 15, 2025 - July 21, 2025			
Week 4: July 22, 2025 - July 28, 2025			
Week 5: July 29, 2025 - August 4, 2025	Ideal	CRNs available for DualEnroll & we see bulk of forms (Would like Aug 1 deadline for CRNs)	CCAP
Week 6: August 5, 2025 - August 11, 2025	Ideal	(NonCCAP) Late Add influx, Appeal Delays, Registration Processing Delays	
Week 6: August 5, 2025 - August 11, 2025	Ideal	Firm Deadline for NonCCAP Petitions (Fall 2025)	NonCCAP
Week 6: August 5, 2025 - August 11, 2025	Ideal	(NonCCAP) Bulk of Petitions come in around this time through first day of AHC classes	NonCCAP
Week 7: August 12, 2025 - August 18, 2025		Start of Fall Term for HS Partners (Average)	
Week 8: August 19, 2025 - August 25, 2025		Start of Fall Term for AHC	
Week 8: August 19, 2025 - August 25, 2025	Actual	(NonCCAP) We accepted petitions for up until the start of classes (extended)	NonCCAP
Week 8: August 19, 2025 - August 25, 2025		Winter app opens	
Week 9: August 26, 2025 - September 1, 2025	Actual	Influx of Fall Petitions Timeframe	Both
Week 9: August 26, 2025 - September 1, 2025	Actual	(NonCCAP) Late Add influx, Appeal Delays, Registration Processing Delays	NonCCAP
Week 10: September 2, 2025 - September 8, 2025	Actual	CRNs available in DualEnroll & we see beginning of bulk of forms	CCAP
Week 10: September 2, 2025 - September 8, 2025	Ideal	Spring app opens for CCAP students	CCAP
Week 11: September 9, 2025 - September 15, 2025			
Week 12: September 16, 2025 - September 22, 2025			
Week 14: September 30, 2025 - October 6, 2025	Ideal	CCAP CRNs available (Spring 2026)	CCAP
Week 14: September 30, 2025 - October 6, 2025	Ideal	CCAP Registration Begins (Spring 2026)	CCAP
Week 14: September 30, 2025 - October 6, 2025		Spring app opens	
Week 14: September 30, 2025 - October 6, 2025	Actual	Deadline for NonCCAP Petitions (Fall 2025 Term 2)	NonCCAP
Week 15: October 7, 2025 - October 13, 2025			
Week 16: October 14, 2025 - October 20, 2025	Actual	AHC accepting NonCCAP petitions (Winter/Spring 2026)	NonCCAP
Week 16: October 14, 2025 - October 20, 2025		Class Search opens	
Week 17: October 21, 2025 - October 27, 2025			
Week 18: October 28, 2025 - November 3, 2025	Ideal	Fall processing complete for CCAP	CCAP
Week 19: November 4, 2025 - November 10, 2025	Actual	CRN available for CCAP for spring	CCAP
Week 20: November 11, 2025 - November 17, 2025	Actual	NonCCAP Registration Begins (Winter/Spring 2026)	NonCCAP
Week 20: November 11, 2025 - November 17, 2025	Actual	CCAP Registration Begins (Early Spring 2026)	CCAP
Week 21: November 18, 2025 - November 24, 2025			
Week 22: November 25, 2025 - December 1, 2025			
Week 23: December 2, 2025 - December 8, 2025	Ideal	Influx of CN Spring Petitions Timeframe	NonCCAP

FALL

SPRING

APPENDIX D Registration Timeline 2025 - 2026

Week 23: December 2, 2025 - December 8, 2025	Ideal	Deadline for NonCCAP Petitions (Winter 2026)	CCAP
Week 24: December 9, 2025 - December 15, 2025	Ideal	Bulk of CCAP registrations submitted for Spring	CCAP
Week 25: December 16, 2025 - December 22, 2024	Actual	Processing completed for Fall CCAP	CCAP
Week 25: December 16, 2025 - December 22, 2025	Actual	Start of Winter Term for AHC	
Week 26: December 23, 2025 - December 29, 2025			
Week 27: December 30, 2025 - January 5, 2026			
Week 28: January 6, 2026 - January 12, 2026	Actual	Deadline for NonCCAP Petitions (Spring 2026)	
Week 29: January 13, 2026 - January 19, 2026	Actual	Start of Spring Term for HS Partners (Average)	Both
Week 29: January 13, 2026 - January 19, 2026	Actual	Influx of CN petitions	Both
Week 30: January 20, 2026 - January 26, 2026	Actual	Start of Spring Term for AHC	
Week 31: January 27, 2026 - February 2, 2026	Actual		
Week 32: February 3, 2026 - February 9, 2026	Actual	We see bulk of our CCAP forms being turned in	CCAP
Week 33: February 10, 2026 - February 16, 2026	Actual	We see bulk of our CCAP forms being turned in	CCAP
Week 34: February 17, 2026 - February 23, 2026		CCAP Sections Identify and Created - Alicia to meet with High Schools (summer/fall 2026)	
Week 35: February 24, 2026 - March 2, 2026			
Week 36: March 3, 2026 - March 9, 2026			
Week 37: March 10, 2026 - March 16, 2026			
Week 38: March 17, 2026 - March 23, 2026			
Week 39: March 24, 2026 - March 30, 2026		CCAP Sections CRNs Complete (summer/fall 2026)	
Week 40: March 31, 2026 - April 6, 2026			
Week 41: April 7, 2026 - April 13, 2026		AHC accepting NonCCAP petitions (summer/fall 2026)	
Week 41: April 7, 2026 - April 13, 2026	Actual	Summer/Fall Class Search Opens	
Week 42: April 14, 2026 - April 20, 2026			
Week 42: April 14, 2026 - April 20, 2026		Priority Reg	
Week 43: April 21, 2026 - April 27, 2026	Ideal	Spring processing complete for CCAP	CCAP
Week 44: April 28, 2026 - May 4, 2026			
Week 45: May 5, 2026 - May 11, 2026	Ideal	<i>NonCCAP Registration Begins (Summer/Fall 2026)</i>	
Week 46: May 12, 2026 - May 18, 2026	Actual	Deadline for NonCCAP Petitions (Spring Term 2 2026)	
Week 47: May 19, 2026 - May 25, 2026	Actual	Spring processing complete for CCAP	
Week 48: May 26, 2026 - June 1, 2026			
Week 49: June 2, 2026 - June 8, 2026	Ideal	Influx of Fall Petitions Timeframe	NonCCAP
Week 50: June 9, 2026 - June 15, 2026	Actual	Start of Summer Term for AHC	
Week 51: June 16, 2026 - June 22, 2026			
Week 52: June 23, 2026 - June 29, 2026			

SPRING

FALL

**COLLEGE AND CAREER ACCESS PATHWAYS (CCAP)
PARTNERSHIP AGREEMENT
BETWEEN
THE ALLAN HANCOCK JOINT COMMUNITY COLLEGE DISTRICT
AND
SANTA YNEZ VALLEY UNION HIGH SCHOOL DISTRICT**

This College and Career Access Pathway Partnership Agreement (“CCAP Agreement”) is between the Allan Hancock Joint Community College District (“COLLEGE”) and Santa Ynez Valley Union High School District (“SCHOOL DISTRICT”). COLLEGE and SCHOOL DISTRICT will collectively be referred to as “PARTIES” or individually as “PARTY”.

RECITALS

WHEREAS, COLLEGE is a community college district whose mission includes providing educational programs and services that are responsive to the needs of the students and communities within the community college services area; and

WHEREAS, SCHOOL DISTRICT is a public school district located within the regional service area of the COLLEGE unless otherwise specified and agreed to as stated in AB 288, Sec. 2, Education Code section 76004, subdivision (e); and

WHEREAS, a high school (“HIGH SCHOOL”) “includes a community school, continuation high school, juvenile court school, or adult education program offering courses for high school diplomas or high school equivalency certificates” as stated in Education Code section 76004, subdivision (a)(2); and

WHEREAS, the PARTIES desire to enter into this CCAP Agreement for the purpose of offering or expanding dual enrollment opportunities, consistent with the provisions of the Education Code, for high school students “who may not already be college bound or who are underrepresented in higher education with the goal of developing seamless pathways from high school to community college for career technical education or preparation for transfer, improving high school graduation rates, and helping high school pupils achieve college and career readiness,” (Ed. Code, § 76004, subdivision (a)); and

WHEREAS, instruction will comply with the student selection standards, curriculum guidelines, recommendations and procedures promulgated by applicable law, the California Community College Chancellor’s Office and the COLLEGE; and

WHEREAS, the PARTIES desire to enter this CCAP, which sets forth their mutual rights and responsibilities and governs their relationship; and

WHEREAS, the PARTIES intend for COLLEGE to report full-time equivalent students (“FTES”) and obtain state apportionment for the subject courses given through this CCAP Agreement in

accordance with California Education Code, section 76004 and the appropriate portions of Title 5 of the California Code of Regulations; and

WHEREAS, participation in the CCAP Agreement is consistent with the core mission of California Community Colleges pursuant to Education Code section 66010.4, and that pupils participating in a CCAP partnership will not lead to enrollment displacement of otherwise eligible adults in the community college (Ed. Code, § 76004, subdivision (k)(2));

NOW, THEREFORE, PARTIES mutually agree as follows:

1. TERM OF AGREEMENT

1.1. **Effective Date and Duration.** The term of this CCAP Agreement shall be effective on **July 1, 2025**, and continue in effect until **June 30, 2026**, or until duly modified or terminated by the PARTIES in accordance with Section 1.2 of this CCAP Agreement.

1.2. Early Termination.

- a. This agreement may be terminated by either PARTY without cause or for any reason upon giving at least sixty (60) days prior written notice to the other PARTY. Any students currently enrolled in COLLEGE courses under this CCAP Agreement shall be allowed to complete those courses prior to the termination of this CCAP Agreement.
- b. This CCAP Agreement may be terminated by either PARTY with cause if another PARTY fails to comply with the insurance or indemnification requirements or otherwise commits a material breach. Termination will be effective no sooner than 15 calendar days after a written demand to cure is provided and the PARTY fails to cure. This remedy is in addition to any other remedy which may be provided for by law.

1.3. **The CCAP Agreement Appendix.** This CCAP Agreement outlines the terms of the Agreement.

- a. The CCAP Agreement Appendix shall specify CCAP Agreement Courses as well as additional details regarding, but not be limited to, the total number of high school students to be served and the total number of full-time equivalent students (“FTES”) projected to be claimed by the community college district for those students; the scope, nature, time, location, and listing of community college courses to be offered; and criteria to assess the ability of pupils to benefit from those courses:

Appendix A: Agreement with Instructor.

Appendix B: Identification of CCAP Pathways for Course-Specific College and Career Pathway Opportunities.

Appendix C: CCAP Agreement Courses Approved for 2025-2026.

Appendix D: Registration Timeline 2025-2026.

- b. The CCAP Agreement Appendix C shall be reviewed and approved annually by both PARTIES by a duly adopted written amendment to this Agreement.

1.4. **Points of contact and Educational Administrators** are as follows:

COLLEGE: Thomas Lamica, dean, academic affairs
 SCHOOL DISTRICT: Dr. Kimberly Sheehan, superintendent/principal
 HIGH SCHOOL SITE: Victoria Martinez, assistant principal

(Ed. Code, § 76004, subdivision (c)(2))

- 1.5. A copy of the COLLEGE and SCHOOL DISTRICT CCAP Agreement shall be filed with the office of the Chancellor of the California Community Colleges and with the California Department of Education before the start of the CCAP partnership. (Ed. Code, § 76004, subdivision (c)(3).)
- 1.6. COLLEGE and SCHOOL DISTRICT shall present this CCAP agreement at an open public meeting of their respective governing boards, allowing for public comments prior to consideration for approval or disapproval of this CCAP agreement. (Ed. Code, § 76004, subdivision (b)(2).)

2. DEFINITIONS

- 2.1. **CCAP Agreement Courses.** CCAP Agreement Courses offered as part of this CCAP Agreement shall be community college courses acceptable towards a career technical education credential or certificate, preparation for transfer, or appropriate to improve high school graduation rates or help high school pupils achieve college and career readiness. (Ed. Code § 76004, subdivision (a).) All community college courses offered at the SCHOOL DISTRICT have been approved in accordance with the policies and guidelines of COLLEGE and applicable law. Courses offered at the COLLEGE that are open to the public for enrollment fall outside of this CCAP agreement and are subject to all conditions and rules of the COLLEGE.
- 2.2. **Pupil or Student Fees.** Pupil or Student is defined as a resident or nonresident student attending HIGH SCHOOL in California. SCHOOL DISTRICT pupils enrolled in a course offered through this CCAP Agreement shall not be assessed any fee that is prohibited by Education Code section 49011 (Ed. Code § 76004, subdivision (f)), including a fee charged to a student or a student's parent or guardian as a condition for course registration or for textbooks, supplies, materials and equipment needed to participate in the course. Students who are enrolled in a combination of CCAP and regular credit college courses will be subject to all fees assessed for the regular credit college enrollment for the regular credit college courses.

3. STUDENT ELIGIBILITY, SELECTION AND ENROLLMENT, ADMISSION, REGISTRATION, MINIMUM SCHOOL DAY

- 3.1. **Student Eligibility.** Students who "may not already be college bound or who are underrepresented in higher education, with the goal of developing seamless pathways from

high school to community college for career technical education or preparation for transfer, improving high school graduation rates, or helping high school pupils to achieve college and career readiness" and "underachieving students, those from groups underrepresented in postsecondary education, those who are seeking advanced studies while in high school, and those seeking a career technical education credential or certificate" are eligible to participate in CCAP courses hosted at a SCHOOL DISTRICT site. (Education Code § 76004, subdivision (a); Assembly Bill 288 (2015) Section I, subdivision (d))

- 3.2. **Student Selection and Enrollment.** Enrollment shall be open to all eligible students as part of the CCAP Agreement who have been admitted to the COLLEGE and who meet all applicable prerequisites. Student selection criteria will be further specified in the CCAP Agreement Appendix C. Applicable prerequisite courses, training, or experience and standards required as preparation for courses offered through the CCAP Agreement will be determined by COLLEGE and shall be in compliance with applicable law and COLLEGE standards and policies.
- 3.3. **College Admission and Registration.** Procedures for students participating in the CCAP Agreement shall be governed by the COLLEGE and shall be in compliance with the admissions and registration guidelines outlined in applicable law and COLLEGE policy.
- 3.4. **Records of Student Attendance.** All records of student attendance and achievement shall be submitted to COLLEGE periodically using the COLLEGE student information system or upon demand and shall be maintained by COLLEGE.
- 3.5. **Priority Enrollment.** Students enrolling in a CCAP course will have priority enrollment by virtue of their status. High school students enrolling in non-CCAP college courses will not be eligible for priority registration.
- 3.6. **Physical Education Courses.** As part of a CCAP Agreement, a participating community college district shall not provide physical education course opportunities to high school students or any other course opportunities that do not assist in the attainment of the goals associated with career technical education or preparation for transfer, improving high school graduation rates, or helping high school students achieve career and college readiness. (Ed. Code § 76004, subdivision (d)).
- 3.7. **Maximum Units.** Students participating under a CCAP Agreement may enroll in up to a maximum of 15 units per term, without exception, if all the following conditions specified in Assembly Bill 288, Sec. 2 (p)(1)(2)(3) are satisfied:
 - a. The units constitute no more than four community college courses per term.
 - b. The units are part of an academic program that is part of a CCAP partnership agreement established pursuant to this article.
 - c. The units are part of an academic program that is designed to award students both a high school diploma and an associate degree or a certificate or credential.
- 3.8. **Minimum School Day.** The SCHOOL DISTRICT shall certify that it shall teach SCHOOL DISTRICT students participating as part of a CCAP Agreement no less than the number of instructional minutes required to complete a minimum school day pursuant to Education Code sections 46141 and 46142.
- 3.9. **Enrollment Restriction.** COLLEGE reserves the right to block students from enrolling in any courses for students who incur an unpaid debt for a non-CCAP class at the college. COLLEGE agrees to remove the enrollment block when debt is paid in full.

4. COLLEGE APPLICATION PROCEDURE

- 4.1. The COLLEGE will be responsible for processing student applications.
- 4.2. The COLLEGE will provide the necessary admission and registration forms and procedures, and both COLLEGE and SCHOOL DISTRICT will jointly ensure that each applicant accepted has met all the enrollment requirements.
- 4.3. The SCHOOL DISTRICT agrees to assist COLLEGE in the admission and registration of SCHOOL DISTRICT students as may be necessary and requested by COLLEGE.

5. PARTICIPATING STUDENTS

- 5.1. The total cost of books and instructional materials for SCHOOL DISTRICT students who enroll in a COLLEGE course offered as part of this CCAP Agreement will be borne by SCHOOL DISTRICT.
- 5.2. Both COLLEGE and SCHOOL DISTRICT will ensure that ancillary and support services are accessible to students (e.g., Tutoring.)
- 5.3. A student taking courses under this CCAP Agreement with an Individual Education Plan or 504 Plan with the SCHOOL DISTRICT may request accommodation for his or her disability to participate in the educational programs and activities required by the COURSE and COLLEGE. Accommodation required by state law or SCHOOL DISTRICT policy will be provided through SCHOOL DISTRICT in consultation with the COLLEGE Learning Assistance Program (LAP) Office. Students requesting services by the LAP office will need to follow the standard process for requesting accommodations.

6. CCAP AGREEMENT COURSES

- 6.1. The COLLEGE may limit enrollment in a community college course solely to eligible high school students if the course is offered at a high school campus during the regular school day and the community college course is offered pursuant to this CCAP Agreement.
- 6.2. The COLLEGE is responsible for all courses and educational programs offered as part of CCAP Agreement .
- 6.3. The scope, nature, time, location, and listing of courses offered by a COLLEGE shall be determined by COLLEGE in consultation with the SCHOOL DISTRICT and with the approval of the COLLEGE and will be recorded in the Appendix C to this CCAP Agreement.
- 6.4. Courses offered as part of a CCAP Agreement shall be jointly selected and approved by COLLEGE and SCHOOL DISTRICT.
- 6.5. Courses offered as part of this CCAP Agreement shall have a minimum enrollment of fifteen (15) students.
- 6.6. The SCHOOL DISTRICT confirms that each approved CCAP course is held for no less than 50 minutes each class day in full compliance with the course outcomes determined by the COLLEGE.
- 6.7. Degree and certificate programs that are included in the CCAP agreement must have been approved by the California Community College Chancellor's Office and courses offered at the SCHOOL DISTRICT shall adhere to the official course outline of record and the student

- learning outcomes established by the associated academic department within the COLLEGE, approved by the COLLEGE Academic Policy & Planning (AP&P) Committee and submitted to the Chancellor's Office. Course outlines will be provided to the SCHOOL DISTRICT.
- 6.8. Courses must meet the number of hours sufficient to meet the stated performance objectives as outlined in the course outlines provided to the SCHOOL DISTRICT on a semester basis.
 - 6.9. Courses offered at the SCHOOL DISTRICT as part of this CCAP Agreement shall be of the same quality and rigor as those offered on the COLLEGE campus and shall be in compliance with COLLEGE academic standards.
 - 6.10. Courses offered as part of this CCAP Agreement will comply with all applicable regulations, policies, procedures, prerequisites, and standards applicable to the COLLEGE as well as any corresponding policies, practices, and requirements of the SCHOOL DISTRICT. In the event of a conflict between the COLLEGE course related regulations, policies, procedures, prerequisites and standards and SCHOOL DISTRICT policies, practices and requirements, the COLLEGE regulations, policies, procedures, prerequisites, and standards, shall prevail.
 - 6.11. A student's withdrawal prior to completion of a course offered as part of this CCAP Agreement shall be in accordance with COLLEGE guidelines, policies, pertinent statutes and regulations.
 - 6.12. Supervision and evaluation of students enrolled in courses offered as part of this CCAP Agreement shall be in accordance with COLLEGE guidelines, policies, pertinent statutes and regulations.
 - 6.13. COLLEGE has the sole right to control and direct the instructional activities for all CCAP Agreement courses and all instructors, including those who are SCHOOL DISTRICT employees.
 - 6.14. This CCAP Agreement certifies that any remedial course taught by community college faculty at a partnering high school campus shall be offered only to high school students who do not meet their grade level standard in math, English, or both on an interim assessment in grade 10 or 11, as determined by the partnering SCHOOL DISTRICT, and shall involve collaborative effort between the SCHOOL DISTRICT and the COLLEGE faculty to deliver an innovative remediation course as an intervention in the student's junior or senior year to ensure the student is prepared for college-level work upon graduation.
 - 6.15. CCAP Agreement Courses outlined in Appendix C shall be updated annually and approved before the start of each academic year.

7. INSTRUCTORS

- 7.1. All instructors teaching COLLEGE courses offered as part of this CCAP Agreement must meet the minimum qualifications for instruction in a California community college as set forth in Title 5 California Code of Regulations, Sections 53410 and 58060 or as amended.
- 7.2. The CCAP Agreement Appendix C shall specify which participating SCHOOL DISTRICT or COLLEGE will be the employer of record for purposes of assignment monitoring and reporting to the county office of education.
- 7.3. This CCAP Agreement specifies that the SCHOOL DISTRICT will assume reporting

responsibilities pursuant to applicable federal teacher quality mandates.

- 7.4. Instructors who teach COLLEGE courses offered as part of this CCAP Agreement must provide the supervision and control reasonably necessary for the protection of the health and safety of students and may not have any other assigned duty during the instructional activity.
- 7.5. Instructors who teach COLLEGE courses shall comply with the fingerprinting requirements set forth in Education Code section 45125 or as amended and the tuberculosis testing and risk assessment requirements of California Health and Safety Code section 121525 or as amended. In addition to any other prohibition or provision, no person who has been convicted of a violent or serious felony shall be eligible to teach any courses offered as part of this CCAP Agreement or otherwise provide services on a SCHOOL DISTRICT site. SCHOOL DISTRICT shall immediately notify COLLEGE if an instructor is charged with an offense prohibited by Education Code sections 44010 or 44011.
- 7.6. Prior to teaching, faculty provided by the SCHOOL DISTRICT shall participate in required discipline-specific training and orientation from COLLEGE regarding, but not limited to, course curriculum, assessment criteria, pedagogy, course philosophy, testing and grading procedures record keeping, and other instructional responsibilities. Such training shall be approved and provided by the COLLEGE.
- 7.7. Prior to teaching, instructors provided by the COLLEGE may receive training and orientation from SCHOOL DISTRICT regarding, but not limited to, SCHOOL DISTRICT policies, practices, and requirements. Such training may be approved and provided by the SCHOOL DISTRICT.
- 7.8. Faculty provided by the SCHOOL DISTRICT are eligible to participate in professional development activities sponsored by the COLLEGE as required by the terms and condition of the contract and shall be encouraged to participate in ongoing collegial interaction to include, but not limited to, addressing course content, course delivery, assessment, evaluation, and/or research and development in the field.
- 7.9. The COLLEGE shall evaluate faculty performance for the college courses using the adopted evaluation of process and standards for faculty of the COLLEGE, subject to the approval of COLLEGE.
- 7.10. The COLLEGE and SCHOOL DISTRICT will work collaboratively to identify instructors from SCHOOL DISTRICT who may meet minimum qualification requirements or local equivalency standards to teach a COLLEGE course and encourage them to apply for consideration. Instructors will be required to go through the COLLEGE screening process for possible selection and assignment to the course.
- 7.11. The SCHOOL DISTRICT teachers approved to teach COLLEGE courses remain employees of the SCHOOL DISTRICT, subject to the authority of the SCHOOL DISTRICT, but will also be subject to the authority of COLLEGE specifically with regard to their duties as COLLEGE instructors, pursuant to the terms of Appendix A.
- 7.12. The COLLEGE shall determine the number of instructors, the ratio of instructors to students, and the subject areas of instruction.
- 7.13. Faculty provided by the SCHOOL DISTRICT who do not comply with the policies, regulations, standards, and expectations of the COLLEGE shall be ineligible to teach college courses under this CCAP Agreement.
- 7.14. SCHOOL DISTRICT teachers approved to teach CCAP Courses under this CCAP

Agreement must submit grades to both the COLLEGE and SCHOOL DISTRICT using the COLLEGE student information system by the established timeline (Appendix D).

- 7.15. SCHOOL DISTRICT teachers approved by the COLLEGE shall sign an Agreement with the Instructor (Appendix A) prior to the start of each academic year.
- 7.16. SCHOOL DISTRICT teachers approved by the COLLEGE shall provide support to high school students taking COLLEGE courses under CCAP agreement with COLLEGE admission and registration procedures.

8. ASSESSMENT OF LEARNING AND CONDUCT

- 8.1. Students enrolled in COLLEGE courses offered as part of this CCAP Agreement at the SCHOOL DISTRICT shall be held to the same standards of achievement as students in courses taught on the COLLEGE campus.
- 8.2. Students enrolled in COLLEGE courses offered as part of this CCAP Agreement at the SCHOOL DISTRICT shall be held to the same grading standards as those expected of students in courses taught on the COLLEGE campus.
- 8.3. Students enrolled in COLLEGE courses offered as part of this CCAP Agreement at the SCHOOL DISTRICT shall be assessed using the same methods (e.g., papers, portfolios, quizzes, labs, etc.) as students in courses taught on the COLLEGE campus.
- 8.4. Students enrolled in COLLEGE courses offered as part of this CCAP Agreement at the SCHOOL DISTRICT shall be held to the same behavioral standards as those expected of students in courses taught on the COLLEGE campus.

9. LIAISON AND COORDINATION OF RESPONSIBILITIES

- 9.1. The COLLEGE shall appoint an educational administrator who will serve as point of contact to facilitate coordination and cooperation between COLLEGE, SCHOOL DISTRICT, and HIGH SCHOOL in conformity with COLLEGE policies and standards. (Ed. Code, § 76004, subd. (c)(2).) Among other things, the COMMUNITY COLLEGE DISTRICT Educational Administrator and the SCHOOL DISTRICT Educational Administrator described in Section 9.2, shall collaborate to determine the process for timely receiving, investigating, and remediating complaints of sexual misconduct or other conduct covered by Title IX of the Education Amendments of 1972 alleged to have occurred in or related to the CCAP program.
- 9.2. The SCHOOL DISTRICT shall appoint an educational administrator who will serve as point of contact to facilitate coordination and cooperation between SCHOOL DISTRICT, COLLEGE, HIGH SCHOOL in conformity with SCHOOL DISTRICT policies and standards.
- 9.3. This CCAP Agreement requires an annual report to the office of the Chancellor of the California Community Colleges by COLLEGE and SCHOOL DISTRICT. COLLEGE shall complete and file the Apportionment Attendance Report (CCFS-320); SCHOOL DISTRICT agrees to provide the following information, when requested by COLLEGE, in accordance with AB 288 Section 2, Education Code Section 76004:
 - a. The total number of high school students by school site enrolled in each partnership, aggregated by gender and ethnicity, and reported in compliance with all applicable state and federal privacy laws.

- b. The total number of community college courses by course category and type and by school site enrolled in by CCAP partnership participants.
- c. The total number and percentage of successful course completions, by course category and type and by school site, of CCAP partnership participants.
- d. The total number of full-time equivalent students generated by CCAP partnership community college district participants.

10. DISPUTES

10.1. COLLEGE and SCHOOL DISTRICT recognize that, from time to time, disputes may arise between COLLEGE employees or students and SCHOOL DISTRICT employees or students. When such disputes arise, COLLEGE and SCHOOL DISTRICT shall collaborate and use their best efforts to resolve them informally. Where informal resolution is not successful or the PARTIES must address a formal inter-agency complaint, the following process will be utilized to resolve the matter.

- a. The PARTY receiving the complaint will timely notify the other, and promptly provide the other PARTY with any written complaint received.
- b. The Educational Administrators will review the complaint to determine, based on the nature of the complaint, whether any statutory or regulatory timelines or other procedural requirements apply, including but not limited to:

10.1.b.1. Whether COLLEGE is required to investigate the complaint to the State Chancellor pursuant to Title 5 of the California Code of Regulations.

10.1.b.2. Whether, based on the nature of the complaint, the complainant is entitled to any rights or protections with regard to how the complaint is handled, pursuant to Title 5 or applicable state or federal laws, including but not limited to Title IX of the Education Amendments of 1972.

10.1.b.3. If either Educational Administrator finds such rights to exist, he or she shall notify the other Educational Administrator, and COLLEGE and SCHOOL DISTRICT shall cooperate as needed in carrying out these requirements. It is understood that such requirements may include but are not limited to conducting a formal investigation within regulatory timelines or the implementation of interim safety measures for the complainant.

- c. Within a reasonable time, either PARTY receiving the complaint, the PARTIES will discuss the nature and severity of the allegations and come to a mutual agreement regarding the need for and scope of any investigation required. If it is agreed that a formal investigation is required, the PARTIES will mutually agree upon an investigator, who may be an outside investigator, or qualified employee of COLLEGE or SCHOOL DISTRICT. If the PARTIES agree to have the matter investigated internally by either a COLLEGE or SCHOOL DISTRICT employee, the other PARTY may designate an employee to attend all witness interviews. Where it is determined that an outside investigator will be used, the cost will be divided between the PARTIES.
- d. If, despite the good faith effort of the PARTIES, they are unable to agree on a process for investigating the complaint, the PARTY whose employee/student is the subject of the complaint will determine the process.

- e. The COLLEGE and SCHOOL DISTRICT will cooperate in any investigation initiated and make its employees available to the investigator.
- f. Interviews of COLLEGE and SCHOOL DISTRICT employees shall comply with any rights and protections afforded to them under an applicable collective bargaining agreement or state or federal law, including but not limited to the right to have a representative present during an interview that could lead to discipline.
- g. The investigator will prepare a report that will be provided to both PARTIES setting forth findings as to the allegations and the basis for the findings.
- h. The COLLEGE and SCHOOL DISTRICT shall share any and all materials from the investigation, unless sharing would cause a PARTY to violate confidentiality or privacy laws.
- i. The COLLEGE and SCHOOL DISTRICT have sole discretion in determining any disciplinary measures to be imposed against their respective employees or students.
- j. Regardless of any disciplinary measures taken by the COLLEGE or SCHOOL DISTRICT against its respective employees or students, the other PARTY retains the right to have the subject of a sustained complaint removed from participating in or providing services for the program that is the subject of this CCAP Agreement.

11. APPORTIONMENT

- 11.1. COLLEGE shall include the students enrolled in a CCAP Agreement course in its report of full-time equivalent students (FTES) for purposes of receiving state apportionments when the course(s) complies with current requirements for dual enrollment under applicable California law.
- 11.2. For purposes of allowances and apportionments from Section B of the State School Fund, a community college district conducting a closed course on a high school campus shall be credited with those units of full-time equivalent students attributable to the attendance of eligible high school pupils.
- 11.3. The COLLEGE shall not receive a state allowance or apportionment for an instructional activity for which the SCHOOL DISTRICT has been, or shall be, paid an allowance or apportionment. (Ed. Code § 76004, subdivision (o)(2)).
- 11.4. The attendance of a SCHOOL DISTRICT pupil at the COLLEGE as a special part-time or full-time student pursuant to this section is authorized attendance for which the COLLEGE shall be credited or reimbursed pursuant to Section 48802 or 76002, provided that no school district has received reimbursement for the same instructional activity.

12. CERTIFICATIONS

- 12.1. The SCHOOL DISTRICT certifies that:
 - a. The direct education costs of the courses offered as part of this CCAP Agreement are not fully funded through other sources.
 - b. It agrees and acknowledges that the COLLEGE will claim apportionment for the SCHOOL DISTRICT students enrolled in community college course(s) under this CCAP Agreement.

- c. Any COLLEGE instructor teaching a course at the SCHOOL DISTRICT has not displaced or resulted in the termination of an existing high school teacher teaching the same course on that high school campus.

12.2. The COLLEGE certifies that:

- a. A community college course offered for college credit at the participating SCHOOL DISTRICT does not reduce access to the same course offered at the partnering COLLEGE.
- b. The COLLEGE has not received full compensation for the direct education costs for the conduct of the courses offered as part of this CCAP Agreement from other sources.
- c. The Agreement is consistent with the core mission of the COLLEGE pursuant to Section 66010.4 and students participating in this CCAP Agreement will not lead to displacement of otherwise eligible adults at the COLLEGE.
- d. A qualified SCHOOL DISTRICT instructor teaching a course offered for college credit at a high school campus has not displaced or resulted in the termination of an existing COLLEGE faculty member teaching the same course at the partnering community college campus.

12.3. The PARTIES certify that:

- a. Any COLLEGE instructor teaching a course on a SCHOOL DISTRICT campus has not been convicted of any sex offense as defined in Education Code section 44010 or as amended, or any controlled substance offense as defined in Education Code section 44011 or as amended.
- b. The SCHOOL DISTRICT and COLLEGE comply with local collective bargaining agreements and all state and federal reporting requirements regarding the qualifications of the teacher or faculty member teaching a CCAP Agreement course offered for high school credit. (AB288 Sec. 2 (I).)

13. PROGRAM IMPROVEMENT

- 13.1. The COLLEGE and the SCHOOL DISTRICT may annually conduct surveys of participating SCHOOL DISTRICT pupils, instructors, principals, and school counselors for the purpose of informing practice, adjusting, and improving the quality of courses offered as part of this CCAP Agreement.

14. RECORDS

- 14.1. Permanent records of student attendance, grades and achievement will be maintained by both the SCHOOL DISTRICT and COLLEGE for SCHOOL DISTRICT students who enroll in course(s) offered as part of this CCAP Agreement. Permanent records of student enrollment, grades, and achievement for COLLEGE students shall be maintained by COLLEGE.
- 14.2. Each PARTY shall maintain records pertaining to this CCAP Agreement as may be required by federal and state law. Each PARTY may review and obtain a copy of the other

PARTY'S pertinent records subject to federal and state privacy statutes.

- 14.3. SCHOOL DISTRICT instructors will submit grades to the COLLEGE when due according to the COLLEGE schedule per section 7.14. The SCHOOL DISTRICT will include all criteria identified by the COLLEGE for grading purposes.
- 14.4. COLLEGE may provide the SCHOOL DISTRICT with a report on participating students' final grades after each term.

15. CCAP AGREEMENT DATA MATCH AND REPORTING

- 15.1. COLLEGE and SCHOOL DISTRICT shall ensure operational protocols consistent with the collection of participating student data and the timely submission of the data.
- 15.2. COLLEGE shall report all program and participating student data to the office of the Chancellor of the California Community Colleges.

16. DATA SHARING

- 16.1. COLLEGE and SCHOOL DISTRICT may share confidential student data for the purposes of evaluating the educational services provided under this CCAP agreement and for evaluating student performance pursuant to participating in CCAP courses. Any data shared will be for research and analytical purposes aimed at understanding student performance and improving applicable federal and state laws concerning access to and confidentiality of student record information as described in Section 17 of this agreement.

17. PRIVACY OF STUDENT RECORDS

- 17.1. COLLEGE and SCHOOL DISTRICT understand and agree that education records of students enrolled in a CCAP course and personally identifiable information contained in those educational records are subject to the Family Educational Rights and Privacy Act (FERPA) 20 U.S.C. § 1232g; 34 C.F.R. Part 99, including the disclosure provisions of § 99.30 and state law as outlined in Education Code section 49064 and section 49076). COLLEGE and SCHOOL DISTRICT agree to hold all student education records generated pursuant to this CCAP Agreement in strict confidence and further agree not to disclose such records except as authorized by applicable law or regulation for COLLEGE records or by the parent or guardian's prior written consent for HIGH SCHOOL records. (34 C.F.R. § 99.33 (a), (b); 34 C.F.R. § 99.34(b) and Education Code §§ 49064 and 49076.)
- 17.2. **Limitation on Use.** COLLEGE and SCHOOL DISTRICT shall use each student education record that they may receive pursuant to this CCAP Agreement solely for purposes consistent with their authority to access that information pursuant to Federal and State law, as may be as applicable. (34 C.F.R. § 99.31, 34 C.F.R. § 99.34, and Education Code § 49076.)
- 17.3. **Recordkeeping Requirements.** COLLEGE and SCHOOL DISTRICT shall comply with the requirements governing maintenance of records of each request for access to and each disclosure of student education records set forth under Title 34, Code of Federal Regulations § 99.32 and under Education Code § 49064 as applicable.
- 17.4. **Acknowledgement of Receipt of Notice of FERPA Regulations.** By signature of its authorized representative or agent on this Agreement, COLLEGE and SCHOOL DISTRICT hereby acknowledges that it has been provided with the notice required under

34 C.F.R. § 99.33(d) that it is strictly prohibited from re-disclosing student education records to any other person or entity except as authorized by applicable law or regulation. Parent or guardian requests for information will need to be addressed directly by the HIGH SCHOOL or SCHOOL DISTRICT personnel.

18. REIMBURSEMENT

- 18.1. The SCHOOL DISTRICT shall invoice the COLLEGE no later than 30 (thirty) days after the start of each term for the instructional services provided through this CCAP agreement as follows:
- a. For courses taught by COLLEGE-approved SCHOOL DISTRICT teachers and COLLEGE instructors on HIGH SCHOOL campuses during regular high school hours rendered at the rate of \$1,000.00 per course unit delivered to CCAP students.

Example: 3 CCAP courses @ 3 units each = 9 units x \$1,000.00 = \$9,000.00

- 18.2. The COLLEGE shall make payment to the SCHOOL DISTRICT within 30 days of receiving the invoice for instructional services rendered.
- 18.3. The COLLEGE is required to report to the state the percentage of funds paid to an agency to the SCHOOL DISTRICT that will provide direct instruction on behalf of the college as part of the CCAP partnership agreement. The SCHOOL DISTRICT will use 100% of all funds received from Allan Hancock College in fulfillment of this agreement to pay for direct instructional costs. (Ed. Code § 84632).

19. FACILITIES

- 19.1. The SCHOOL DISTRICT will provide adequate classroom space at its facilities or other mutually agreed upon locations to conduct the instruction and do so without charge to COLLEGE or students. SCHOOL DISTRICT agrees to clean, maintain, and safeguard SCHOOL DISTRICT's premises. SCHOOL DISTRICT warrants that its facilities are safe and compliant with all applicable buildings, fire, and safety codes.
- 19.2. The SCHOOL DISTRICT will furnish, at its own expense, all course materials, specialized equipment, books and other necessary equipment for all SCHOOL DISTRICT students. The parties understand that such equipment and materials are the SCHOOL DISTRICT's sole property.
- 19.3. The SCHOOL DISTRICT facilities may be used by COLLEGE for COLLEGE course offerings before or after regular high school schedule at no additional cost. Prior approval by the SCHOOL DISTRICT is required. COLLEGE courses offered before or after the regular high school schedule will be open to the public.

20. INDEMNIFICATION

- 20.1. The SCHOOL DISTRICT agrees to and shall indemnify, save and hold harmless the COLLEGE, and its governing board, officers, employees, administrators, independent

contractors, subcontractors, agents and other representatives from any and all claims, demands, liabilities, costs, expenses, damages, causes of action, losses, and judgments, arising out of SCHOOL DISTRICT's performance of this CCAP Agreement. The obligation to indemnify shall extend to all claims and losses that arise out of SCHOOL DISTRICT's or its trustees', officers', agents', or employees' negligence, wrongful acts or omissions, or willful misconduct related to this CCAP Agreement or performance of this CCAP Agreement. The provisions of this section shall survive the termination or expiration of this CCAP Agreement.

20.2. The COLLEGE agrees to and shall indemnify, save and hold harmless the SCHOOL DISTRICT and its governing board, officers, employees, administrators, independent contractors, subcontractors, agents and other representatives from any and all claims, demands, liabilities, costs, expenses, damages, causes of action, losses, and judgments, arising out of COLLEGE'S performance of this CCAP Agreement. The obligation to indemnify shall extend to all claims and losses that arise out of COLLEGE'S or its trustees', officers', agents', or employees' negligence, wrongful acts or omissions, or willful misconduct related to this CCAP Agreement or performance of this CCAP Agreement. The provisions of this section shall survive the termination or expiration of this CCAP Agreement.

21. INSURANCE

21.1. The SCHOOL DISTRICT, in order to protect the COLLEGE, its agents, employees and officers against claims and liability for death, injury, loss and damage arising out of or in any manner connected with the performance and operation of the terms of this CCAP Agreement, shall secure and maintain in force during the entire term of this CCAP Agreement, insurance coverage or an approved program of self-insurance in the amount of not less than ONE MILLION DOLLARS (\$1,000,000) per incident and TWO MILLION DOLLARS (\$2,000,000) general aggregate for personal injury, bodily injury, death, and property and other damage, with an admitted California insurer duly licensed to engage in the business of insurance in the State of California, or public entity risk management Joint Powers Authority, authorized to provide public liability and property damage insurance in the state of California. Said policy of insurance, insurance coverage through a public entity risk management JPA, or program of self-insurance shall expressly name the COLLEGE, its agents, employees and officers as an additional insured for the purposes of this CCAP Agreement. A certificate of insurance including such endorsement shall be furnished to the COLLEGE.

21.2. The COLLEGE, in order to protect the SCHOOL DISTRICT, its agents, employees and officers against claims and liability for death, injury, loss and damage arising out of or in any manner connected with the performance and operation of the terms of this CCAP Agreement, shall secure and maintain in force during the entire term of this CCAP Agreement, insurance coverage or an approved program of self-insurance in the amount of not less than ONE MILLION DOLLARS (\$1,000,000) per incident and TWO MILLION DOLLARS (\$2,000,000) general aggregate for personal injury, bodily injury, death, and property and other damage, with an admitted California insurer duly licensed to engage in the business of insurance in the State of California, or public entity risk management Joint Powers Authority, authorized to provide public liability and property damage insurance in the State

of California. Said policy of insurance, insurance coverage through a public entity risk management JPA or program of self-insurance shall expressly name the SCHOOL DISTRICT, its agents, employees and officers as an additional insured for the purposes of this CCAP Agreement. A certificate of insurance including such endorsement shall be furnished to the SCHOOL DISTRICT.

- 21.3. For the purpose of Workers' Compensation, SCHOOL DISTRICT shall be the "primary employer" for all its employees who perform services as instructors and support staff. SCHOOL DISTRICT shall be solely responsible for processing, investigating, defending, and paying all workers' compensation claims by their respective SCHOOL DISTRICT employees made in connection with performing services and receiving instruction under this CCAP Agreement. SCHOOL DISTRICT agrees to hold harmless, indemnify, and defend COLLEGE, its directors, officers, agents, and employees from any liability resulting from its failure to process, investigate, defend, or pay any workers' compensation claims by SCHOOL DISTRICT employees connected with providing services under this CCAP Agreement.

22. NON-DISCRIMINATION

- 22.1. Neither the SCHOOL DISTRICT nor the COLLEGE shall discriminate on the basis of race or ethnicity, gender, nationality, physical or mental disability, sexual orientation, religion, or any other protected class under California State or federal law.

23. NOTICES

- 23.1. Any and all notices required to be given hereunder shall be deemed given when personally delivered or deposited in the U.S. Mail, postage to be prepaid, to the following addresses:

Allan Hancock College Joint Community College District
800 S. College Drive
Santa Maria, CA 93460
Attn: Dennis Curran

Santa Ynez Valley Union High School District
Address: 2975 Mission Drive, Solvang, CA 93463
Attn: Victoria Martinez

24. MODIFICATION AND AMENDMENT

- 24.1. Appendix A through D to this CCAP Agreement is incorporated by this reference into this CCAP Agreement.
- 24.2. This CCAP Agreement and Appendix A through D to this CCAP Agreement set forth the entire agreement between the PARTIES relating to the subject matter of this CCAP Agreement. This CCAP Agreement and Appendix A through D to this CCAP Agreement supersede any prior agreements, promises, negotiations, or representations, express or implied, oral or written, not included in this CCAP Agreement and Appendix A through D

to this CCAP Agreement.

24.3. This Agreement may be amended only with the mutual consent of the Parties. All amendments must be in writing and must be approved by the Parties' respective governing Boards.

25. GOVERNING LAWS

25.1. This CCAP Agreement will be governed by and construed in accordance with California law, and the venue of any action or proceeding in connection with this CCAP Agreement shall be Santa Barbara County, California.

26. COMMUNITY COLLEGE DISTRICT BOUNDARIES

26.1. For locations outside the geographical boundaries of Allan Hancock College Joint Community College District, the COLLEGE will comply with the requirements of Title 5 of the California Code of Regulations, Sections 55300 et seq. or as amended, concerning approval by adjoining high school or community college districts and use of non-district facilities.

27. SEVERABILITY

27.1. This CCAP Agreement shall be considered severable, such that if any provision or part of the CCAP Agreement is ever held invalid under any law or ruling, that provision or part of the CCAP Agreement shall remain in force and effect to the extent allowed by law, and all other provisions or parts shall remain in full force and effect.

28. COUNTERPARTS

28.1. This CCAP Agreement may be executed by the PARTIES in separate counterparts, each of which when so executed and delivered shall be an original, but all such counterparts shall together constitute one and the same instrument.

IN WITNESS WHEREOF, the PARTIES hereto have caused this CCAP Agreement to be executed on the dates set forth below, to be effective as of the Effective Date.

ALLAN HANCOCK JOINT COMMUNITY COLLEGE DISTRICT

SANTA YNEZ VALLEY UNION HIGH SCHOOL DISTRICT

By: _____
Associate Superintendent/Vice President of Finance and Administration

By: _____
Superintendent/Principal

Date: _____

Date: _____

ALLAN HANCOCK JOINT COMMUNITY
COLLEGE DISTRICT BOARD MEETINGS

SANTA YNEZ VALLEY UNION HIGH
SCHOOL DISTRICT BOARD MEETINGS

Information Board Meeting Date:

Information Board Meeting Date:

Public Comment
and Approval Board Meeting Date:

Public Comment
and Approval Board Meeting Date:

APPENDIX A

ALLAN HANCOCK COLLEGE JOINT COMMUNITY COLLEGE DISTRICT

Agreement with INSTRUCTOR

This agreement is made and entered into this _____ [day] of _____ [month] ____ [year] by three parties: The Allan Hancock College Joint Community College District (hereinafter “COLLEGE”), the _____ [high school district] (hereinafter “SCHOOL DISTRICT”) and _____ [first name, last name], an employee of the SCHOOL DISTRICT (hereinafter “INSTRUCTOR”) who is being assigned to the COLLEGE on a part-time basis pursuant to Title 5, California Code of Regulations, section 58058(b).

WHEREAS, the SCHOOL DISTRICT has the experience, training, equipment and other resources, and staff necessary to provide instruction to COLLEGE students through the CCAP Agreement;

WHEREAS, Title 5, California Code of Regulations, section 58050, subdivision (a) provides authority for claiming apportionment;

NOW, THEREFORE, the three parties to this Agreement hereby agree as follows:

1. The SCHOOL DISTRICT’s INSTRUCTOR is an employee of the SCHOOL DISTRICT who shall meet “Minimum Qualifications” for the academic position of COLLEGE’s INSTRUCTOR as established by the COLLEGE and as determined by the COLLEGE.
2. The SCHOOL DISTRICT’s INSTRUCTOR is professionally and specially trained and competent to provide the supervisory and/or instructional services required by the COLLEGE.
3. The INSTRUCTOR will be an employee of the COLLEGE for purposes of the Attendance Accounting Standards (Ed. Code, § 58050). COLLEGE has the right to; 1) evaluate and terminate INSTRUCTOR; 2) evaluate the quality of instruction to ensure that it meets the needs of students; 3) evaluate the quality and rigor equal to the COLLEGE’S approved course outline of record and the accreditation requirements of COLLEGE. The COLLEGE will not provide INSTRUCTOR evaluation results to the SCHOOL DISTRICT.
4. The SCHOOL DISTRICT’s INSTRUCTOR shall at all times comply with the supervisory and/or instructional requirements outlined in Title 5, California Code of Regulations, section 58055, which require direct instruction by the SCHOOL DISTRICT’s INSTRUCTOR except in limited circumstances. The SCHOOL DISTRICT’s INSTRUCTOR’s responsibilities and duties as an employee of the COLLEGE shall include, but are not limited to, the following:
 - 4.1. Ensure that an instructional time of 50 minutes per class each day is expended in full compliance with the course objectives determined by the COLLEGE.
 - 4.2. Ensure the safety and well-being of students.
 - 4.3. Be in sufficient physical proximity and range of communication to provide immediate instructional supervision and control of all students in his/her classes.
 - 4.4. Attend periodic staff meetings with the COLLEGE.
 - 4.5. Regularly check and respond to communication from COLLEGE.
 - 4.6. Priority in class enrollment shall be given to students desiring to take the course for college credit towards a degree or certificate (Ed. Code § 76370). Ensure accurate and current daily student attendance records, accurate calculation of final student grades of

all students enrolled in the course for college credit, and the prompt submission of all data necessary for the calculation of FTES to the DISTRICT within 3 (three) calendar days of course completion (Ed. Code § 84500).

- 4.7. Ensure the effective use of instructional methods, technology, testing and remediation.
 - 4.8. Ensure that he/she does not have any other assigned duties during the instructional activity where multiple skill levels of students are being taught for which attendance is being claimed.
 - 4.9. Be familiar with and comply with all relevant COLLEGE policies, rules and regulations, including but not limited, to those related to student safety, grading, attendance, sexual harassment and discrimination.
 - 4.10. Provide support to SCHOOL DISTRICT students taking COLLEGE courses under CCAP agreement with COLLEGE admission and registration procedures.
5. The SCHOOL DISTRICT shall indemnify and hold harmless the COLLEGE and its authorized agents, officers, and employees against any and all claims and actions arising from the SCHOOL DISTRICT's INSTRUCTOR's or SCHOOL DISTRICT's negligent, reckless or intentional acts, errors or omissions and for any cost or expense incurred by the COLLEGE on account of any claim therefor.
 6. The COLLEGE shall provide no compensation to the SCHOOL DISTRICT's INSTRUCTOR for any services rendered pursuant to this Agreement, but compensation, as well as workers' compensation insurance, shall be the responsibility of the SCHOOL DISTRICT in accordance with its established and standard practices.
 7. This Agreement may be terminated at any time by the COLLEGE within the sole and exclusive discretion of the COLLEGE upon written notice to the SCHOOL DISTRICT and the SCHOOL DISTRICT's INSTRUCTOR. This Agreement may be terminated upon thirty (30) days' prior written notice to COLLEGE by either the SCHOOL DISTRICT or the SCHOOL DISTRICT's INSTRUCTOR within either's sole and exclusive discretion.

IN WITNESS WHEREOF, the parties hereto have executed this Agreement the day and year last written below.

INSTRUCTOR

ALLAN HANCOCK COLLEGE JOINT
COMMUNITY COLLEGE DISTRICT

Print

Print

Signature

Signature

APPENDIX B

Identification of CCAP Pathways for Course-Specific College and Career Pathway Opportunities

Pursuant to California Assembly Bill No. 288, the COLLEGE and SCHOOL DISTRICT enter into this partnership agreement to offer College and Career Pathways (CCAP) to high school students to expand dual enrollment opportunities to facilitate college and career readiness, particularly among students who may not already be college-bound or who are underrepresented in higher education.

The goal of the CCAP partnership is to offer seamless pathways from high school to community college to promote: 1) academic preparation for transfer to four-year colleges and universities; 2) completion of career and technical education programs for entry into the workforce; (3) improving high school graduation rates, and (4) helping high school pupils achieve college and career readiness.

The following pathways are included in the CCAP partnership agreement between the COLLEGE and SCHOOL DISTRICT:

Career and Technical Education:

1. This pathway includes COLLEGE courses in a Career and Technical education (“CTE”) pathway at the college level that apply to an Allan Hancock College degree or certificate in the pathway. This includes:
 - a. Naming of HIGH SCHOOL Pathway and Course Location in Sequence (Introductory, Concentrator, Capstone, or Practicum)
 - b. Naming of COLLEGE Pathway – Degree or Certificate
 - c. Identifying Career/Employment Outcomes associated with CTE Pathway
 - d. Identifying the course(s) in the Pathway to be offered under the CCAP Agreement.
2. Examples of CTE Technical Pathways include Automotive, Digital Art and Graphic Design, Culinary, Early Childhood Studies, Welding etc.

College and Career Readiness:

1. This pathway includes COLLEGE courses in career exploration and career development that prepare students in college and career planning. Successful completion of these courses will allow students to matriculate at college level in courses in a CTE pathway or General Education/California State University (“CSU”) Transfer pathway.
2. Course examples include: WEE (Work Experience); PD (Career Planning).

Preparation for Transfer:

1. California General Education Transfer Curriculum (Cal-GETC). This pathway includes COLLEGE courses which have been approved to meet the lower-division general education requirements at any CSU or University of California campus (i.e. Areas 1-6)

Improve High School Graduation Rates:

1. Student participation in college courses improves graduation rates of students who participate compared to peers who do not participate in college-level coursework.

APPENDIX C

CCAP Agreement Courses Approved for 2025 - 2026

HIGH SCHOOL DISTRICT: Santa Ynez Valley Union High School District

HIGH SCHOOL SITE: Santa Ynez Valley Union High School

PROJECTED NUMBER OF STUDENTS TO BE SERVED: 605

TOTAL PROJECTED FTES: 129.09

CCAP Pathway	College Degree or Certificate	High School Pathway	CCAP Course Offerings		Number of Sections, High School period(s) & Times		Instructor Name & Employer of Record (AHC or HS)		Projected Number of Students	Projected FTES
			FALL	SPRING	FALL	SPRING	FALL	SPRING		
Career Technical Education	Agricultural Science - AS	Agriculture and Natural Resources	AG 152	Vet Science	1 periods/ times TBD	1 periods/ times TBD	Heather Clement (HS)	Heather Clement (HS)	30	3.09
Career Technical Education	Agricultural Science - AS	Agriculture and Natural Resources	AG 154	AG 156	1 periods/ times TBD	1 periods/ times TBD	Kylin Bray (HS)	Kylin Bray (HS)	25	5.14
Career Technical Education	Sports Medicine - AS	Patient Care	WEE 149	ATH 104 WEE 149	TBD	1 periods/ times TBD	TBD (AHC)	TBD (HS) TBD (AHC)	20	4.80
Career Technical Education	Auto Body Tech – AS	Service and Repair	AT 100	AB 351	1 periods/ times TBD	1 periods/ times TBD	Gary Semerdjian	Gary Semerdjian	40	16.46
Career Technical Education	Admin of Justice – AS	Admin of Justice	AJ 101	AJ 105	1 periods/ times TBD	1 periods/ times TBD	TBD (AHC)	TBD (AHC)	20	4.12
Career Technical Education	Admin of Justice: Cyber Security - CA	Cyber Security	AJ 160	AJ 162	1 periods/ times TBD	1 periods/ times TBD	TBD (AHC)	TBD (AHC)	20	4.12

Preparation for Transfer	AA-T Cal-GETC	HS graduation requirement	ENGL C1000	ENGL C1001	3 periods/ times TBD	3 periods/ times TBD	3 periods/ times TBD	Casey Reek (HS) Patrick Shattuck(HS)	75	18.00
Preparation for Transfer	AA-T Cal-GETC	HS graduation requirement	POLS 103	ECON 101	2 periods/ times TBD	2 periods/ times TBD	2 periods/ times TBD	Casey Reek (HS) Patrick Shattuck (HS) Robert Cantrell (HS) Greg Wolf (HS)	40 cohorts rotate	8.22
Preparation for Transfer	AA-T Cal-GETC	HS graduation requirement	ECON 101	POLS 103	2 periods/ times TBD	2 periods/ times TBD	2 periods/ times TBD	Robert Cantrell (HS) Greg Wolf (HS)	40 cohorts rotate	8.22
Preparation for Transfer	AA-T Cal-GETC	HS graduation requirement	-	COMM C1000	-	1 periods/ times TBD	1 periods/ times TBD	AHC (TBD)	20	2.06
Preparation for Transfer	Film and Video Production - CA	Arts, Media and Entertainment	FILM 102	FILM 110	2 periods/ times TBD	2 periods/ times TBD	2 periods/ times TBD	TBD (HS)	40	13.72
Preparation for Transfer	Film and Video Production - CA	Arts, Media and Entertainment	High school course	MMAC 126	1 periods/ times TBD	1 periods/ times TBD	1 periods/ times TBD	TBD (HS)	25	5.14
Preparation for Transfer	AA-T Cal-GETC	HS graduation requirement	HIST 107	HIST 108	3 periods/ times TBD	3 periods/ times TBD	3 periods/ times TBD	Greg Wolf (HS)	90	18.52
Preparation for Transfer	AA-T Cal-GETC	HS graduation requirement	PSY 101	SOC 101	1 periods/ times TBD	1 periods/ times TBD	1 periods/ times TBD	TBD (AHC)	20	4.12
Preparation for Transfer	AA-T Cal-GETC	Arts, Media and Entertainment	ART 101	MUS 101	1 periods/ times TBD	1 periods/ times TBD	1 periods/ times TBD	TBD (AHC)	20	4.12
Preparation for Transfer	AA-T Cal-GETC	HS graduation requirement	ASL 120	ASL 121	1 periods/ times TBD	1 periods/ times TBD	1 periods/ times TBD	TBD (AHC)	40	8.22
Preparation for Transfer	Dance - AA	Arts, Media and Entertainment	DANC 107	DANC 133	1 periods/ times TBD	1 periods/ times TBD	1 periods/ times TBD	TBD (AHC)	40	12.34

1. **Required:** Describe the criteria used to assess the ability of pupils to benefit from the course(s) offered:

In consultation with their SCHOOL DISTRICT counselors, students self-select a pathway based on their academic readiness and alignment of course content to students' educational and career goals. SCHOOL DISTRICT and COLLEGE faculty identified CCAP courses using the following criteria:

- Alignment with HIGH SCHOOL pathways and COLLEGE programs of study.
- Potential for course completion to accelerate students' time to completion of postsecondary degree or certificate.
- Potential to earn a Certificate of Training and be eligible to enter the workforce in their selected career technical pathway.
- Potential to work toward completion of an associate degree or an associate degree for transfer.

2. **MINIMUM QUALIFICATIONS FOR INSTRUCTION:** All instructors teaching CCAP Agreement Courses must meet the minimum qualifications for instruction in a California community college as set forth in Title 5 of the California Code of Regulations, sections 53410 and 58060 or as amended. The minimum qualifications for instruction are:

Course Name & Number	Minimum Qualifications For Instructors
AB 351	<ul style="list-style-type: none"> Any bachelor's degree or higher and two years of professional experience OR any associate degree and six years of professional experience. <p>NOTE: Professional experience is required when the application possesses a master's degree. The professional experience required must be directly related to the teaching assignment.</p>
AG 152 AG 154 AG 156	<ul style="list-style-type: none"> Any bachelor's degree or higher and two years of professional experience OR any associate degree and six years of professional experience. Professional experience is required when the application possesses a master's degree. The professional experience required must be directly related to the teaching assignment. OR a master's degree in agriculture, agricultural science, education with a specialization in agriculture or other agricultural area, including agricultural business, agricultural engineering, agricultural mechanics, agronomy, animal science, enology, environmental (ornamental) horticulture, equine science, forestry, natural resources, plant science, pomology, soil science, viticulture or other agriculture science OR the equivalent
AJ 101 AJ 105	<ul style="list-style-type: none"> Any bachelor's degree or higher and two years of professional experience OR any associate degree and six years of professional experience.

AJ 160 AJ 162	NOTE: Professional experience is required when the application possesses a master's degree. The professional experience required must be directly related to the teaching assignment.
ART 101	<ul style="list-style-type: none"> • Master's degree in fine arts, art, or art history • OR bachelor's degree in any of the above AND master's degree in humanities • OR the equivalent <p>NOTE: "master's degree in fine arts" as used here refers to any master's degree in the subject matter of fine arts, which is defined to include visual studio arts such as drawing, painting, sculpture, printmaking, ceramics, textiles, and metal and jewelry art, and also art education and art therapy. It does not refer to the "Master of Fine Arts" (MFA) degree when that degree is based on specialization in performing arts or dance, film, video, photography, creative writing or other nonplastic arts.</p>
ASL 120 ASL 121	<ul style="list-style-type: none"> • Master's degree in American Sign Language • OR bachelor's degree in American Sign Language AND master's degree in another language or linguistics • OR the equivalent
AT 100	<ul style="list-style-type: none"> • Any bachelor's degree or higher and two years of professional experience • OR any associate degree and six years of professional experience. <p>NOTE: Professional experience is required when the application possesses a master's degree. The professional experience required must be directly related to the teaching assignment.</p>
ATH 104	<ul style="list-style-type: none"> • Any bachelor's degree or higher and two years of professional experience • OR any associate degree and six years of professional experience. <p>NOTE: Professional experience is required when the application possesses a master's degree. The professional experience required must be directly related to the teaching assignment.</p>
COMM C1000	<ul style="list-style-type: none"> • Master's degree in speech, speech broadcasting, telecommunications, rhetoric, communication, communication studies, speech communication or organizational communication • OR bachelor's degree in any of the above AND master's degree in drama/theater arts, mass communication or English • OR the equivalent
DANC 107 DANC 133	<ul style="list-style-type: none"> • Master's degree in dance, physical education with a dance emphasis, or theater with dance emphasis • OR bachelor's degree in any of the above AND master's degree in physical education, any

	<p>life science, physiology, theater arts, kinesiology, humanities, performing arts or music</p> <ul style="list-style-type: none"> • OR any bachelor's degree or higher and two years of professional experience in Folk Dance • OR any associate degree and six years of professional experience in Folk Dance. Professional experience is required when the application possesses a master's degree. The professional experience required must be directly related to the teaching assignment • OR the equivalent
ENGL C1000 ENGL C1001	<ul style="list-style-type: none"> • Master's degree in English, literature, comparative literature, or composition • OR bachelor's degree in any of the above AND master's degree in linguistics, TESL, speech, or education with a specialization in reading, creative writing or journalism • OR the equivalent
FILM 102 FILM 110	<ul style="list-style-type: none"> • Master's degree in film/cinema and media studies, film, television, and media studies, drama/theater, and mass communication • OR bachelor's degree in any of the above AND master's degree in visual studies, media studies, English, or communication • OR the equivalent
HIST 107 HIST 108	<ul style="list-style-type: none"> • Master's degree in history • OR bachelor's degree in history AND master's degree in political science, humanities, geography, area studies, women's studies, social science or ethnic studies • OR the equivalent
MMAC 126	<ul style="list-style-type: none"> • Master's degree in fine arts, art, or art history • OR bachelor's degree in any of the above AND master's degree in humanities <p>NOTE: "master's degree in fine arts" as used here refers to any master's degree in the subject matter of fine arts, which is defined to include visual studio arts such as drawing, painting, sculpture, printmaking, ceramics, textiles, and metal and jewelry art, and also art education and art therapy. It does not refer to the "Master of Fine Arts" (MFA) degree when that degree is based on specialization in performing arts or dance, film, video, photography, creative writing, or other non-plastic arts.)</p> <ul style="list-style-type: none"> • OR master's degree in film/cinema and media studies, film, television, and media studies, drama/theater, mass communication • OR bachelor's degree in any of the above AND master's degree in visual studies, media studies, English, or communication • OR the equivalent • OR Any bachelor's degree or higher and two years of professional experience • OR any associate degree and six years of professional experience. <p>NOTE: Professional experience is required when the application possesses a master's degree.</p>

	The professional experience required must be directly related to the teaching assignment
MUS 101	<ul style="list-style-type: none"> • Master's degree in music • OR bachelor's degree in music AND master's degree in humanities • OR the equivalent
POLS C1000	<ul style="list-style-type: none"> • Master's degree in political science, government, or international relations • OR bachelor's degree in any of the above AND master's degree in economics, history, public administration, social science, sociology, and any ethnic studies, Juris Doctor Degree (J.D.) or Legum Baccalaureus (LL.B.) • OR the equivalent
PSYC C1000	<ul style="list-style-type: none"> • Master's degree in psychology • OR bachelor's degree in psychology AND master's degree in counseling, sociology, statistics, neuroscience or social work • OR the equivalent
SOC 101	<ul style="list-style-type: none"> • Master's degree in sociology • OR bachelor's degree in sociology AND master's degree in anthropology, any ethnic studies, social work, or psychology • OR the equivalent
WEE 149	<ul style="list-style-type: none"> • The minimum qualifications in any discipline in which work experience may be provided

3. **BOOKS AND INSTRUCTIONAL MATERIALS:** The total cost of books and instructional materials for SCHOOL DISTRICT students participating in CCAP course as part of this CCAP Agreement will be borne by SCHOOL DISTRICT. Current pricing and textbook availability are published on the COLLEGE bookstore website each semester.
4. **JOINT FACILITIES USE PROTOCOLS:** COLLEGE and SCHOOL DISTRICT shall adhere to the terms and protocols outlined in Section 19, Facilities, of the CCAP Agreement. SCHOOL DISTRICT, shall extend access and use of the following SCHOOL DISTRICT facilities:

BUILDING NAME & ADDRESS	CLASSROOM	DAYS	HOURS
SYVUHS 2975 Mission Drive, Solvang, CA 93463	C1, C2, C3, C4	Monday through Friday	8:00 am – 9:00 pm

SYVUHS 2975 Mission Drive, Solvang, CA 93463	L1, L2, L3, L4, L5	Monday through Friday	8:00 am – 9:00 pm
SYVUHS 2975 Mission Drive, Solvang, CA 93463	E1, E2, E3, E4, E5, E6	Monday through Friday	8:00 am – 9:00 pm
SYVUHS 2975 Mission Drive, Solvang, CA 93463	S1, S2, S3, S4, S5, S6	Monday through Friday	8:00 am – 9:00 pm
SYVUHS 2975 Mission Drive, Solvang, CA 93463	EP1 and EP2	Monday through Friday	8:00 am – 9:00 pm
SYVUHS 2975 Mission Drive, Solvang, CA 93463	P1, P2, P3, P4, P5, P6, P7, P8, P9, P10, P14, P15, P16, P17, P18, P19, P20, P21, P22	Monday through Friday	8:00 am – 9:00 pm
SYVUHS 2975 Mission Drive, Solvang, CA 93463	VE1 and VE2	Monday through Friday	8:00 am – 9:00 pm
SYVUHS 2975 Mission Drive, Solvang, CA 93463	IA1	Monday through Friday	8:00 am – 9:00 pm
SYVUHS 2975 Mission Drive, Solvang, CA 93463	Music Room	Monday through Friday	8:00 am – 9:00 pm
SYVUHS 2975 Mission Drive, Solvang, CA 93463	R1, R2, R3, R4	Monday through Friday	8:00 am – 9:00 pm

ALLAN HANCOCK JOINT COMMUNITY COLLEGE
DISTRICT

By: _____
Vice-President, Academic Affairs

Date: _____

By: _____
Vice-President, Finance & Administration

Date: _____

SANTA YNEZ VALLEY UNION HIGH SCHOOL

By: _____
Principal

Date: _____

By: _____
Head Counselor

Date: _____

APPENDIX D Registration Timeline 2025 - 2026

2025-2026 Week Ranges	Process	Timeline	Type
Week 1: July 1, 2025 - July 7, 2025			
Week 2: July 8, 2025 - July 14, 2025			
Week 3: July 15, 2025 - July 21, 2025			
Week 4: July 22, 2025 - July 28, 2025			
Week 5: July 29, 2025 - August 4, 2025	Ideal	CRNs available for DualEnroll & we see bulk of forms (Would like Aug 1 deadline for CRNs)	CCAP
Week 6: August 5, 2025 - August 11, 2025	Ideal	(NonCCAP) Late Add influx, Appeal Delays, Registration Processing Delays	
Week 6: August 5, 2025 - August 11, 2025	Ideal	Firm Deadline for NonCCAP Petitions (Fall 2025)	NonCCAP
Week 6: August 5, 2025 - August 11, 2025	Ideal	(NonCCAP) Bulk of Petitions come in around this time through first day of AHC classes	NonCCAP
Week 7: August 12, 2025 - August 18, 2025		Start of Fall Term for HS Partners (Average)	
Week 8: August 19, 2025 - August 25, 2025		Start of Fall Term for AHC	
Week 8: August 19, 2025 - August 25, 2025	Actual	(NonCCAP) We accepted petitions for up until the start of classes (extended)	NonCCAP
Week 8: August 19, 2025 - August 25, 2025		Winter app opens	
Week 9: August 26, 2025 - September 1, 2025	Actual	Influx of Fall Petitions Timeframe	Both
Week 9: August 26, 2025 - September 1, 2025	Actual	(NonCCAP) Late Add influx, Appeal Delays, Registration Processing Delays	NonCCAP
Week 10: September 2, 2025 - September 8, 2025	Actual	CRNs available in DualEnroll & we see beginning of bulk of forms	CCAP
Week 10: September 2, 2025 - September 8, 2025	Ideal	Spring app opens for CCAP students	CCAP
Week 11: September 9, 2025 - September 15, 2025			
Week 12: September 16, 2025 - September 22, 2025			
Week 14: September 30, 2025 - October 6, 2025	Ideal	CCAP CRNs available (Spring 2026)	CCAP
Week 14: September 30, 2025 - October 6, 2025	Ideal	CCAP Registration Begins (Spring 2026)	CCAP
Week 14: September 30, 2025 - October 6, 2025		Spring app opens	
Week 14: September 30, 2025 - October 6, 2025	Actual	Deadline for NonCCAP Petitions (Fall 2025 Term 2)	NonCCAP
Week 15: October 7, 2025 - October 13, 2025			
Week 16: October 14, 2025 - October 20, 2025	Actual	AHC accepting NonCCAP petitions (Winter/Spring 2026)	NonCCAP
Week 16: October 14, 2025 - October 20, 2025		Class Search opens	
Week 17: October 21, 2025 - October 27, 2025			
Week 18: October 28, 2025 - November 3, 2025	Ideal	Fall processing complete for CCAP	CCAP
Week 19: November 4, 2025 - November 10, 2025	Actual	CRN available for CCAP for spring	CCAP
Week 20: November 11, 2025 - November 17, 2025	Actual	NonCCAP Registration Begins (Winter/Spring 2026)	NonCCAP
Week 20: November 11, 2025 - November 17, 2025	Actual	CCAP Registration Begins (Early Spring 2026)	CCAP
Week 21: November 18, 2025 - November 24, 2025			
Week 22: November 25, 2025 - December 1, 2025			
Week 23: December 2, 2025 - December 8, 2025	Ideal	Influx of CN Spring Petitions Timeframe	NonCCAP

FALL

SPRING

APPENDIX D Registration Timeline 2025 - 2026

Week 23: December 2, 2025 - December 8, 2025	Ideal	Deadline for NonCCAP Petitions (Winter 2026)	CCAP
Week 24: December 9, 2025 - December 15, 2025	Ideal	Bulk of CCAP registrations submitted for Spring	CCAP
Week 25: December 16, 2025 - December 22, 2024	Actual	Processing completed for Fall CCAP	CCAP
Week 25: December 16, 2025 - December 22, 2025	Actual	Start of Winter Term for AHC	
Week 26: December 23, 2025 - December 29, 2025			
Week 27: December 30, 2025 - January 5, 2026			
Week 28: January 6, 2026 - January 12, 2026	Actual	Deadline for NonCCAP Petitions (Spring 2026)	
Week 29: January 13, 2026 - January 19, 2026	Actual	Start of Spring Term for HS Partners (Average)	Both
Week 29: January 13, 2026 - January 19, 2026	Actual	Influx of CN petitions	Both
Week 30: January 20, 2026 - January 26, 2026	Actual	Start of Spring Term for AHC	
Week 31: January 27, 2026 - February 2, 2026	Actual		
Week 32: February 3, 2026 - February 9, 2026	Actual	We see bulk of our CCAP forms being turned in	CCAP
Week 33: February 10, 2026 - February 16, 2026	Actual	We see bulk of our CCAP forms being turned in	CCAP
Week 34: February 17, 2026 - February 23, 2026		CCAP Sections Identify and Created - Alicia to meet with High Schools (summer/fall 2026)	
Week 35: February 24, 2026 - March 2, 2026			
Week 36: March 3, 2026 - March 9, 2026			
Week 37: March 10, 2026 - March 16, 2026			
Week 38: March 17, 2026 - March 23, 2026			
Week 39: March 24, 2026 - March 30, 2026		CCAP Sections CRNs Complete (summer/fall 2026)	
Week 40: March 31, 2026 - April 6, 2026			
Week 41: April 7, 2026 - April 13, 2026		AHC accepting NonCCAP petitions (summer/fall 2026)	
Week 41: April 7, 2026 - April 13, 2026	Actual	Summer/Fall Class Search Opens	
Week 42: April 14, 2026 - April 20, 2026			
Week 42: April 14, 2026 - April 20, 2026		Priority Reg	
Week 43: April 21, 2026 - April 27, 2026	Ideal	Spring processing complete for CCAP	CCAP
Week 44: April 28, 2026 - May 4, 2026			
Week 45: May 5, 2026 - May 11, 2026	Ideal	<i>NonCCAP Registration Begins (Summer/Fall 2026)</i>	
Week 46: May 12, 2026 - May 18, 2026	Actual	Deadline for NonCCAP Petitions (Spring Term 2 2026)	
Week 47: May 19, 2026 - May 25, 2026	Actual	Spring processing complete for CCAP	
Week 48: May 26, 2026 - June 1, 2026			
Week 49: June 2, 2026 - June 8, 2026	Ideal	Influx of Fall Petitions Timeframe	NonCCAP
Week 50: June 9, 2026 - June 15, 2026	Actual	Start of Summer Term for AHC	
Week 51: June 16, 2026 - June 22, 2026			
Week 52: June 23, 2026 - June 29, 2026			

SPRING

FALL

To: Board of Trustees	Date:
From: Superintendent/President	July 15, 2025
Subject: Approval to Award Contract for the Espresso Stand Operations (RFP #25-05)	Item Number: 8.G.
Institutional Goal: Accreditation Standard III	Enclosures: Page 1 of 3

BACKGROUND

On April 15, 2025, the board of trustees authorized staff to solicit proposals for the operation of the espresso stand in the G building of the Santa Maria campus. The project was listed with Cyber Copy Reprographics and advertised in the Santa Maria Times on April 24 and May 1, 2025. On May 13, 2025, an optional job walk was held with six vendors present.

On June 9, 2025, proposals were due and five responsive proposals were received from the following vendors: Cali Cup LLC, Glorificate Coffee Delight, Starry Sky Coffee Company, Testa's Campus Cuisine, and Woven Coffee Roasters.

An evaluation committee of six district representatives reviewed and evaluated the proposals. Glorificate Coffee Delight, Woven Coffee Roasters, Starry Sky Coffee Company and Testa's Campus Cuisine were selected for a follow-up interview. Interviews were conducted June 23-25, 2025 and after careful consideration, the interview committee unanimously agreed that the proposal from Glorificate Coffee Delight provides the best value for the District.

FISCAL IMPACT

None

RECOMMENDATION

Staff recommends the board of trustees award the contract to Glorificate Coffee Delight for the Espresso Stand Operations (RFP #25-05) for the Santa Maria campus.

Administrator Initiating Item: Dennis Curran	Final Disposition:
---	--------------------



REQUEST FOR PROPOSAL OPENING RESULTS

Project: **ESPRESSO STAND OPERATIONS**
RFP No. 25-05

RFP Due Date: June 9, 2025 at 2:00 P.M.

BIDDER	Original Signed Price Proposal	Electronic Copy of Proposal	Non-Collusion Certification	Certificate of Compliance	Addendum 1 & 2 Acknowledged
Cali Cup LLC	X	X	X	X	
Glorificate Coffee Delight	X	X	X	X	
Starry Sky Coffee Company	X	X	X	X	X
Testa's Campus Cuisine	X	X	X	X	X
Woven Coffee Roasters	X	X	X	X	

Opened By: Kara Pizano Witnessed By: Dennis Curran, Laura Becker, Monica Garcia

ESPRESSO STAND OPERATIONS- PERCENTAGE OF GROSS REVENUE

Vendor	Year 1	Year 2	Year 3	Year 4	Year 5
Cali Cup LLC	5%	7%	9%	11%	13%
Glorificate Coffee Delight	8%	9%	10%	11%	12%
Starry Sky Coffee Company	5%	5%	5%	5%	5%
Testa's Campus Cuisine	10%	10%	10%	10%	10%
Woven Coffee Roasters	2%**	6%**	6%**	6%**	6%**

***Testa's Campus Cuisine:** If awarded the contract, they request that their existing food services contract coincide with the terms of the Espresso Stand contract.

****Woven Coffee Roasters:** 2% during the first 3 months, 6% on month 4 onward. Upon reaching \$150,000 annual sales the percentage will increase to 7%. If awarded contract, requesting reduced operating hours based on several factors (low current revenue, industry, campus dynamics, on-site observations, and better financial alignment). They also recommend against pursuing the proposed mobile cart at Fine Arts (insufficient revenue, proximity concerns, increased staffing costs).



CONSENT ITEM

To: Board of Trustees	Date: July 15, 2025
From: Superintendent/President	
Subject: Approval to Award Contract for the Campus Road and Parking Lot Slurry Seal and Restriping Project (Bid #25-06)	Item Number: 8.H.
Institutional Goal: Accreditation Standard III	Enclosures: Page 1 of 2

BACKGROUND

On May 20, 2025, the board of trustees authorized staff to bid the repairs for the Campus Road and Parking Lot Slurry Seal and Restriping Project (Bid #25-06). The project was listed with Cyber Copy Reprographics and advertised in the Santa Maria Times on March 21 and March 28, 2025. On June 2, 2025 a mandatory job walk was held with one contractor present. A decision was made to hold two additional job walks on June 9 and June 12, 2025, with a total of six additional contractors present.

The district received four responsive bids on the June 30, 2025 due date. As indicated on the attached bid tabulation form, the responsive and lowest bidder for this project was Mission Paving with a base bid and alternates 1-8 totaling \$339,179.

FISCAL IMPACT

The bid amount is \$339,179 and will be funded through Parking Funds.

RECOMMENDATION

Staff recommends the board of trustees award the contract for repairs of the Campus Road and Parking Lot Slurry Seal and Restriping Project (Bid #25-06), effective 5:00 pm PST, July 16, 2025, to Mission Paving Inc. in the amount of \$339,179.

Administrator Initiating Item: Dennis Curran	Final Disposition:
---	--------------------

BID TABULATION
CAMPUS ROAD AND PARKING LOT SLURRY SEAL & RESTRIPING PROJECT
BID NO. 25-06
JUNE 30, 2025 at 2:00 p.m.

BIDDER	MISSION PAVING INC.	PAVE WEST LLC	RAMSEY ASPHALT CONSTRUCTION	GENERAL PAVEMENT MANAGEMENT INC.
Base Bid	\$ 154,350.00	\$ 135,603.92	\$ 254,801.00	\$ 349,943.00
Alt No. 1	\$ 19,950.00	\$ 38,212.52	\$ 26,122.00	\$ 19,963.00
Alt No. 2	\$ 14,543.00	\$ 28,627.08	\$ 19,876.00	\$ 14,822.00
Alt No. 3	\$ 33,857.00	\$ 53,397.08	\$ 36,029.00	\$ 39,596.00
Alt No. 4	\$ 11,908.00	\$ 22,140.68	\$ 20,167.00	\$ 17,123.00
Alt No. 5	\$ 5,984.00	\$ 7,082.64	\$ 13,658.00	\$ 5,961.00
Alt No. 6	\$ 27,135.00	\$ 52,403.96	\$ 32,882.00	\$ 28,658.00
Alt No. 7	\$ 36,505.00	\$ 68,924.52	\$ 42,190.00	\$ 40,794.00
Alt No. 8	\$ 34,947.00	\$ 59,148.24	\$ 36,949.00	\$ 27,930.00
Total	\$ 339,179.00	\$ 465,540.64	\$ 482,674.00	\$ 544,790.00

Opened by: Kara Pizano

Witnessed by: Isaac Perez, Christopher Cruz, Grant Sanregret, Monica Garcia, Steve Marshall

To: Board of Trustees	Date:
From: Superintendent/President	July 15, 2025
Subject: Approval of Notice of Completion for Heating, Ventilation and Air-Conditioning Updates for the District	Item Number: 8.I.
Institutional Goal: Accreditation Standard III	Enclosures: Page 1 of 1

BACKGROUND

On December 14, 2021, the board of trustees adopted Resolution 21-26, Emergency Procurement of Heating Ventilation and Air Conditioning Upgrades and Authorize the Agreement for Furnishing and Installing Heating, Ventilation and Cooling System Upgrades with SitelogIQ, Inc., in the amount of \$3,455,126.

During the course of the project, the district approved two change orders, one of which was a reduction in cost, thereby bringing the project to a grand total of \$3,447,270.

The work is now complete. Therefore, it is appropriate for the district to file a notice of completion with the Santa Barbara County Recorder's Office. The filing of the notice of completion starts the 30-day period within which subcontractors or material suppliers must file any stop payment notices. Upon completion of the time period and with no outstanding stop notices, the college is obligated to release all remaining funds to the contractor.

FISCAL IMPACT

There is no fiscal impact to file a notice of completion.

RECOMMENDATION

Staff recommends the board of trustees approve filing a Notice of Completion for Heating, Ventilation and Air-Conditioning Updates for the District.

Administrator Initiating Item: Dennis Curran	Final Disposition:
---	--------------------



CONSENT ITEM

To: Board of Trustees	Date:
From: Superintendent/President	July 15, 2025
Subject: Authorization for Out-of-State Travel for Students	Item Number: 8.J.
Institutional Goal: Accreditation Standard II	Enclosures: Page 1 of 1

BACKGROUND

The Associated Student Body Government, Allan Hancock College, would like to send two students to the HACU (Hispanic Association of Colleges and Universities) Conference in Aurora Colorado, November 1 – 3, 2025.

The conference will provide general sessions, keynote speakers, workshops and forums designed to educate the student participants on the major issues that are critical to community colleges. While attending and participating in the conference, students are learning about important issues and collaboration with college administrators. The conference serves as a very strong educational experience.

FISCAL IMPACT

Approximately \$5,200 for the two students. The President’s Office, Allan Hancock College, will cover the costs of travel, lodging, transportation and per diem.

RECOMMENDATION

Staff recommend the board of trustees authorize two students to attend the HACU Conference in Aurora Colorado, November 1 – 3, 2025.

Administrator Initiating Item: Genevieve Siwabessy	Final Disposition:
---	--------------------

To: Board of Trustees	Date: July 15, 2025
From: Superintendent/President	
Subject: Second Review of Revised Board Policy 3930, Minors on Campus	Item Number: 8.K.
Institutional Goal: Accreditation Standard II	Enclosures: Page 1 of 3

BACKGROUND

Board Policy 3930, Minors on Campus, was presented for the board's review on June 10, 2025. It is being presented to the board of trustees for adoption

The revised board policy has been vetted through the shared governance process.

FISCAL IMPACT

None

RECOMMENDATION

Staff recommends the board of trustees adopt board policy 3930, Minors on Campus, as submitted.

Administrator Initiating Item: Genevieve Siwabessy	Final Disposition:
---	--------------------



**Allan Hancock Joint Community College District
Board Policy
Chapter 3 – General Institution**

BP 3930 MINORS ON CAMPUS

The primary mission of the college is to educate students eligible to enroll in community college courses. The District has the responsibility to provide a place of instruction which is free from internal as well as external distraction. To provide a place of instruction which is free from distraction requires that some restrictions be placed on children on campus. In addition to concerns about the ability to carry out the District's mission, the presence of children in campus facilities raises safety and liability issues.

This policy statement addresses issues raised by the presence of children on the campus and provides guidance for students and employees of the District.

The District and its facilities (classrooms, offices, public service areas and grounds) are not a substitute for childcare arrangements. This policy does not preclude an adult from bringing children on campus for visits, such as the examples listed in the Exceptions section, but when the reason for the child's presence is to take the place of childcare services, then it is inappropriate for the child to be on site.

At no time may children be unattended or unsupervised on campus. The terms "unattended" and "unsupervised" are used to refer to situations in which the child is on campus or in a campus facility and is not under the immediate physical control of an adult or an instructor, for example, College for Kids classes. Likewise, children may not be left unattended in public areas such as the library and the cafeteria while the adult is in class. Nor may a child be left to wait or play outside a classroom while the accompanying adult is in class.

Only enrolled students may be present in classrooms or lab facilities when classes are in session. Children may not attend class or class activities such as field trips, along with enrolled students. Moreover, children may not be present at an employee's work site during the employee's assigned work hours. This does not preclude short visits when the child is accompanied by another responsible adult.

Employees must advise students that it is a violation of Board policy to allow children in the classroom. Students who do not comply with a request to remove dependent children from class will be subject to BP/AP 5500 Standards of Student Conduct.

Employees and students should not allow minors to be left unattended on campus. Employees or students who observe children who appear to be unattended should contact the Allan Hancock College Police Department. The Allan Hancock College Police Department will handle the matter in accordance with appropriate State of California education and penal codes.

Definitions:

For purposes of this policy, the definition of a minor is any person under the age of eighteen years of age. Emancipated minors are considered adults. Adult refers to a responsible person over the age of eighteen or an emancipated minor.

Exceptions:

Exceptions to this policy are campus facilities or activities which, by their very nature, might be attended by children. It is assumed, however, that children in these facilities or attending these activities are under the supervision of an instructor or adult or are enrolled in a fee-based program. Examples of such activities would be athletic events, performing arts performances, College for Kids, children's center lab schools, and other activities planned for children.

In certain courses, children may occasionally be included in classrooms or other academic settings for activities that contribute to the achievement of course objectives and student learning outcomes. In such cases, appropriate permissions will be obtained from the parent(s)/legal guardian(s).

This policy does not apply to minors who are enrolled in college courses as special admit student. Program enrollment materials contain a statement of conditions of enrollment and requires a parent or guardian's signature as stipulated by statute.

Certain campus services are open to the public or community users, for example, the cafeteria, library, and pool. As long as an adult or guardian is present with the child, the child may be in the facility. However, if the child becomes disruptive or the presence of the child interferes with the peaceful conduct of the activities of the campus, the adult may be asked to remove the child.

References: No references

Adopted: 6/20/95

Revised: 9/15/04

Revised: 4/11/17

To: Board of Trustees	Date:
From: Superintendent/President	July 15, 2025
Subject: Second Review of Revised Board Policy 5410, Associated Students Elections	Item Number: 8.L.
Institutional Goal: Accreditation Standard II	Enclosures: Page 1 of 2

BACKGROUND

Board Policy 5410, Associated Students Elections, was presented for the board's review on June 10, 2025. It is being presented to the board of trustees for adoption

The revised board policy has been vetted through the shared governance process.

FISCAL IMPACT

None

RECOMMENDATION

Staff recommends the board of trustees adopt board policy 5410, Associated Students Elections, as submitted.

Administrator Initiating Item: Genevieve Siwabessy	Final Disposition:
---	--------------------



**Allan Hancock Joint Community College District
Board Policy
Chapter 5 – Student Services**

BP 5410 ASSOCIATED STUDENTS ELECTIONS

The Associated Students shall conduct annual elections to elect officers. The elections shall be conducted in accordance with procedures established by the Superintendent/President.

Any student elected as an officer in the Associated Students shall meet any of the following requirements:

- The student shall be enrolled in the District at the time of election and throughout the student's term of office, with a minimum of eight semester units or the equivalent quarter units.
- The student shall meet and maintain the minimum grade point average (GPA) of 2.00 and the standards of scholarship (see BP 4220 Standards of Scholarship and related administrative procedures).
- The student shall be enrolled in an adult education program offered by the District at the time of the election and throughout the student's term
- The student is enrolled in the District at the time of election, and throughout the student's term, and is a disabled student.

Reference:

Education Code Section 76061

Adopted: 7/14/15

Reviewed: 10/13/20

To: Board of Trustees	Date:
From: Superintendent/President	July 15, 2025
Subject: Adoption of Resolution 25-28, Approval to Withdraw from Self-Insured Schools of California and Establish a New Self-Insurance Fund Account with the County of Santa Barbara for Self-Insurance Medical Benefits	Item Number: 9.A.
Institutional Goal: Accreditation Standard III	Enclosures: Page 1 of 3

BACKGROUND

The Allan Hancock Joint Community College District (“District”) is terminating its relationship with our medical insurance administrator, Self-Insured Schools of California (SISC), and moving to a self-insured program administered by Benefits and Risk Management Services, Inc. (BRMS) in partnership with HUB International from Santa Maria as the broker. Changing administrators requires that we notify SISC of our intent to withdraw from their insurance group as of September 30, 2025. The district’s notice to SISC is attached for information.

The Santa Barbara County Auditor-Controller’s Office requires a board resolution to open a new fund, which will be titled “Medical Self-Insurance Fund”. The attached resolution establishes the new fund and provides notice to the Auditor-Controller’s Office. The new fund will be used to accrue medical insurance benefit payments received and to pay medical claims and pay plan administration costs. Any reserves due to the District upon termination of the SISC contract will be deposited into the new fund as a reserve for future medical insurance costs.

FISCAL IMPACT

There is no fiscal impact to establishing the new fund. The amount of the SISC reserve account will be determined when the agreement with SISC is cancelled on September 30, 2025.

RECOMMENDATION

Staff recommends the board of trustees adopt Resolution 25-28, Approval to Withdraw from Self-Insured Schools of California and Establish a New Self-Insurance Fund Account with the County of Santa Barbara for Self-Insurance Medical Benefits.

Administrator Initiating Item: Dennis Curran	Final Disposition:
---	--------------------



July 16, 2025

Self-Insured Schools of California
P.O. Box 1847
2000 "K" Street
Bakersfield, CA 93303-1847

Re: Notice to Withdraw from SISC

To Whom it May Concern:

In accordance with section 14 of the Joint Powers Agreement for the operation of a common risk management and insurance program, the Allan Hancock Joint Community College District (AHJCCD) is providing notice to the Self-Insured Schools of California (SISC) Board that AHJCCD intends to withdraw from SISC effective October 1, 2025. We request the following:

- Detailed information on our claims run out timeline
- The status and amount of our reserves
- Disbursement of our reserve amount to AHJCCD on October 1, 2025
- 2025 calendar year accumulator files on October 1, 2025
- Statement identifying and quantifying all outstanding liabilities for claims incurred during the self-insured period for the Fiscal Year ending on June 30, 2026.

Please confirm in writing, at your earliest convenience, the expected amount of reserve funds to be disbursed to AHJCCD and receipt of this letter.

Dennis D. Curran
Assoc. Superintendent/Vice President
Finance and Administration

Kevin G. Walthers, Ph.D.
Superintendent/President

**RESOLUTION NO. 25-28
A RESOLUTION OF THE BOARD OF TRUSTEES OF
THE ALLAN HANCOCK JOINT COMMUNITY COLLEGE DISTRICT**

**APPROVAL TO WITHDRAW FROM SELF-INSURED SCHOOLS OF CALIFORNIA AND
ESTABLISH A NEW SELF-INSURANCE FUND ACCOUNT WITH THE COUNTY OF SANTA
BARBARA FOR SELF-INSURED MEDICAL BENEFITS**

WHEREAS, the Allan Hancock Joint Community College District (“District”) desires to establish a self-insured medical benefit program to better serve the needs of its employees and the District; and

WHEREAS, the District will terminate its relationship with its current medical insurance administrator, Self-Insured Schools of California (SISC) and transition to a self-insured program administered by Benefits and Risk Management Services, Inc. (BRMS) in partnership with HUB International as the broker; and

WHEREAS, the District desires to establish a new fund held by the County of Santa Barbara entitled “AHJCCD Medical Self-Insurance Fund” to accrue medical insurance benefit payments received and to pay medical claims and plan administration costs.

NOW, THEREFORE, BE IT RESOLVED AND ORDERED by the GOVERNING BOARD of ALLAN HANCOCK JOINT COMMUNITY COLLEGE DISTRICT:

That the Board of Trustees of the Allan Hancock Joint Community College District hereby requests that the Santa Barbara County Auditor-Controller’s Office open the AHJCCD – Medical Self-Insurance Fund for the Allan Hancock Joint Community College District.

BE IT FURTHER RESOLVED that the governing board hereby approves the President/Superintendent to take such actions as may be reasonably necessary to perform the following tasks:

The District’s delivery of a written notice of withdrawal from SISC and the withdrawal of District self-insurance funds from SISC; and

The deposit of any and all District self-insurance reserves from the SISC account into the District’s new fund established by the County of Santa Barbara to be held as a reserve for the District’s medical claims for the District’s self-insurance program to be administered by HUB International.

PASSED AND ADOPTED this 15th day of July 2025 by the following votes:

AYES:
NOES:
ABSENT:
ABSTAIN:

Hilda Zacarias
President, Board of Trustees

To: Board of Trustees	Date: July 15, 2025
From: Superintendent/President	
Subject: Acceptance of Grants Approved and Review of Grant Proposals Submitted	Item Number: 9.B.
Institutional Goal: Accreditation Standard II	Enclosures: Page 1 of 2

BACKGROUND**Acceptance of Grants Approved**

Institutional Grants has been notified of funding for the following grants in the amount of \$175,000.

1. All Within My Hands Foundation: Metallica Scholars Initiative (\$75,000)

Funding will support the college's Firefighter Academy program. Funding will cover the cost of protective equipment, scholarships, and textbooks for 60 students in the program. Metallica Scholars is a major workforce education initiative that provides direct support to community colleges to enhance their career and technical education programs. These programs provide skills and services to students looking to enter a traditional trade or other applied learning program. The All Within My Hands Foundation was implemented by the heavy metal band, Metallica.

No matching funds are required. The project period is for one year from July 1, 2025 – June 30, 2026. (Submitted by Jon Hooten).

2. Santa Barbara County Public Health Department: Opioid Unified Response Community Partner Grants (\$100,000)

Funding to expand opioid prevention and harm reduction programs on campus and the broader community. Harm reduction strategies include training, hosting weekly Narcotics Anonymous meetings for students, distributing Narcan and testing strips, and developing culturally responsive awareness to foster belonging for students in recovery.

No matching funds are required. The project period is for two years from July 1, 2025, to June 30, 2026. (Submitted by Chief Farley)

FISCAL IMPACT

1. All Within My Hands Foundation: Metallica Scholars Initiative (\$75,000)
2. Santa Barbara County Public Health Department: Opioid Unified Response Community Partner Grants (\$100,000)

RECOMMENDATION

Staff recommends the board of trustees accept contracts for a total of \$175,000 in restricted funds to the district, as submitted.

Administrator Initiating Item: Jon Hooten	Final Disposition:
--	--------------------

Review of Grant Proposals Submitted

Institutional Grants has submitted the following grant applications for a total of \$753,238 in requested funds.

1. Department of Education: Developing Hispanic Serving Institutions (\$600,000)

Allan Hancock College First Year Experience (FYE) aims to improve retention and overall persistence rates by enhancing student success through mentorship, early intervention, and faculty development. This initiative focuses on engagement for Hispanic male and first-generation students by providing Student Success Mentors, embedded tutoring, and wraparound support services, especially in foundational English and Math courses. The program also includes faculty-led workshops to share effective teaching strategies, fostering a strong sense of connection and belonging for first-year students.

No matching funds are required. The project period is October 1, 2026 – September 30, 2029. (Submitted by Mary Patrick and Yvonne Teniente).

2. Schnieder Foundation: Commercial Truck Driving Program (\$153,238)

Locally, the Central Coast anticipates the retirement of 2,151 employees in the trucking sector within the next 5–10 years. To address this critical gap, the program prepares students for the California Commercial Driver's License (CDL) through five non-credit courses; however, only three of the five courses are required for completion. Despite the program being tuition-free, students must cover licensing and medical fees required prior to class enrollment.

No matching funds are required. The project period is July 1, 2025 – June 30, 2026. (Submitted by Alicia Paniagua).

To: Board of Trustees	Date:
From: Superintendent/President	July 15, 2025
Subject: Chapter 2 Board Policies	Item Number: 10.A.
Institutional Goal: Accreditation Standard IV	Enclosures: Page 1 of 48

BACKGROUND

The Community College League of California board policy templates are divided into seven chapters. Chapter 2 board policies relate to how the board holds meetings and delegates authority. Per administrative procedure 2410, Board Policies and Administrative Procedures, all policies and procedures are to be reviewed on a five-year cycle. Twenty-eight board policies and two administrative procedures were presented to the board for review at the May 20, 2025, board meeting. The board of trustees requested the board policies be reviewed in more depth at the July board retreat.

The highlighted policies in the following list have been updated to align with the revised accreditation standards, government codes, and district practices.

Administrator Initiating Item: Kevin G. Walthers	Final Disposition:
---	--------------------



Chapter 2 Policies up for Five-year Review

Table of Contents

	Title	Page
Board Composition	BP 2010 Board Membership	3
	BP 2100 Board Elections	5
	<ul style="list-style-type: none"> <i>District boundaries updated</i> 	
	BP 2110 Vacancies on the Board	7
	BP 2200 Board Duties and Responsibilities	8
	BP 2210 Officers	10
Board Meetings	BP 2220 Committees of the Board	12
	BP 2305 Annual Organizational Meeting	13
	BP 2315 Closed Sessions	14
	<ul style="list-style-type: none"> <i>Added citation to the Government Code to clarify when a governing board may hold a closed session.</i> 	
	BP 2320 Special and Emergency Meetings	16
	BP 2330 Quorum and Voting	17
	BP 2350 Speakers	19
BP 2360 Minutes	20	
BP 2365 Recording	21	

Board Oversight	BP 2410 Board Policies and Administrative Procedures	22
	BP 2430 Delegation of Authority to the Superintendent/ President	25
	<ul style="list-style-type: none"> • <i>Updates to align with 2024 Accreditation Standards</i> 	
	BP 2431 Superintendent/President Selection	27
	BP 2432 Superintendent/President Succession	28
	BP/AP 2435 Evaluation of the Superintendent/President	29
	BP/AP 2510 Shared Governance	32
Board Member Guidelines/Benefits	BP 2610 Presentation of Initial Collective Bargaining Proposals	37
	BP 2715 Code of Ethics/Standards of Practice	38
	<ul style="list-style-type: none"> • <i>The Service updated this policy to add supporting language pursuant to the 2024 changes in the ACCJC Accreditation Standards.</i> 	
	BP 2716 Political Activity	41
	BP 2717 Personal Use of Public Resources	42
	BP 2730 Board Member Health Benefits	43
	BP 2735 Board Member Travel	44
	BP 2740 Board Education	45
BP 2745 Board Self-Evaluation	46	
BP 2750 Board Member Absence from the State	47	

- *Policy updates*



**Allan Hancock Joint Community College District
Board Policy
Chapter 2 – Board of Trustees**

BP 2010 BOARD MEMBERSHIP

The Board shall consist of five members elected by the qualified voters of the District. Members shall be elected by trustee area as defined in BP 2100 titled Board Elections.

Any person who meets the criteria contained in law is eligible to be elected or appointed a member of the Board.

An employee of the District may not be sworn into office as an elected or appointed member of the Board unless he/she resigns as an employee.

Board members and employees shall not engage in any employment or activity that is inconsistent with, incompatible with, in conflict with or inimical to the Board member's duties as an officer of the District. A Board member shall not simultaneously hold two public offices that are incompatible. When two offices are incompatible, a Board member shall be deemed to have forfeited the first office upon acceding to the second.

AUTHORITY

The Allan Hancock College Board of Trustees derives its authority from the Education Code of the State of California. The Board is subject to the provisions of the Constitution of California, the Education Code, the Rules and Regulations of the State Board of Education (Title 5, California Administrative Code), the Board of Governors of California Community Colleges, and its own policies and procedures. It acts at the express will of the electorate and represents the interests of the public exclusively.

Board members have authority only when acting as a Board of Trustees legally in session. The Board will not be bound in any way by any statement or action on the part of any individual board member or employee, except when such statement or action is in pursuance of specific instructions by the Board.

The Board of Trustees will not take any position advocating or opposing a local, state, or national legislative matter unless the issue is of direct concern to the District.

References: Education Code Sections 72023, 72103, and 72104

Adopted: 6/18/91
Revised: 8/18/92
Revised: 4/20/93
Revised: 4/26/94
Revised: 11/22/94
Revised: 3/21/95
Revised: 5/16/95

Revised: 3/19/96
Revised: 4/21/98
Revised: 6/20/00
Revised: 11/18/14
Reviewed: 9/8/20



**Allan Hancock Joint Community College District
Board Policy
Chapter 2 – Board of Trustees**

BP 2100 BOARD ELECTIONS

The governance of the Allan Hancock Joint Community College District of Santa Barbara, San Luis Obispo, and Ventura Counties is vested in the Board of Trustees, consisting of five members each elected by voters of his/her trustee area. Each trustee is elected or appointed from one of the five trustee areas, and the purpose of the areas is to provide for area representation of all the territory in the District. Each trustee area will have approximately the same number of registered voters. In order to equalize trustee area population, the trustee areas are reapportioned in the year following the release of federal census data collected through the national census.

The Superintendent/President shall submit recommendations to the Board regarding adjustments to be made to the boundaries of each trustee area, if any adjustment is necessary, after each decennial federal census. The Superintendent/President shall submit the recommendation in time for the Board to act as required by law.

Effective ~~December 12, 2014~~ January 11, 2022 the trustee areas are:

- Area 1 ~~Central and Northern Santa Maria~~
- Area 2 ~~South East Santa Maria, Orcutt, and Cuyama Valley~~
- Area 3 ~~Southern Santa Maria and Guadalupe~~
- Area 4 ~~Lompoc Valley~~
- Area 5 ~~Casmalia, Santa Ynez Valley, and Vandenberg AFB~~

The District website includes maps of the trustee areas.

The election of a Board member residing in and registered to vote in the trustee area he/she seeks to represent shall be only by the registered voters of the same trustee areas.

Each trustee must be a resident of and a qualified voter in the trustee area he/she represents. The term of office is four years, with service beginning the second Friday in December following the general election.

Election of members to the Board shall be held biennially on the first Tuesday after the first Monday in November of each succeeding even-numbered year to fill the offices of

members whose terms expire the first Friday in December. Terms of trustees are staggered so that, as nearly as practical, one-half of the trustees shall be elected at each trustee election.

If a member of the Board moves his/her place of residence outside the boundaries of the district, or his/her trustee area, such a change of residence shall effect an automatic resignation and create a vacancy on the Board.

References: Education Code Sections 5000 et seq., 72022, and 72036

Adopted: 6/18/91	Revised: 5/16/95
Revised: 8/18/92	Revised: 3/19/96
Revised: 4/20/93	Revised: 4/21/98
Revised: 4/26/94	Revised: 6/20/00
Revised: 11/22/94	Revised: 5/19/15
Revised: 3/21/95	Revised: 7/9/19
	Reviewed: 9/8/20



**Allan Hancock Joint Community College District
Board Policy
Chapter 2 – Board of Trustees**

BP 2110 VACANCIES ON THE BOARD

Vacancies on the Board of Trustees may be caused by any of the events specified in Government Code Section 1770 or any applicable provision of the California Elections Code or by a failure to elect. Resignations from the Board shall be governed by Education Code Section 5090.

Within 60 days of the vacancy or filing of a deferred resignation, the Board shall either order an election or make a provisional appointment to fill the vacancy.

If an election is ordered, it shall be held on the next regular election date no less than 130 days after the occurrence of the vacancy.

If a provisional appointment is made, it shall be subject to the conditions in Education Code Section 5091. The person appointed to the position shall hold office only until the next regularly scheduled election for District governing Board members, when the election shall be held to fill the vacancy for the remainder of the unexpired term.

The provisional appointment will be made by a majority public vote of the Board members at a public meeting.

The Superintendent/President shall establish administrative procedures to solicit applications that assure ample publicity to and information for prospective candidates. The Board will determine the schedule and appointment process, which may include interviews at a public meeting.

References: Education Code Sections 5090 et seq.
Government Code 1770

Adopted: 11/16/04
Revised: 4/16/13
Revised: 11/18/14

Reviewed: 9/8/20



**Allan Hancock Joint Community College District
Board Policy
Chapter 2 – Board of Trustees**

BP 2200 BOARD DUTIES AND RESPONSIBILITIES

The Board of Trustees governs on behalf of the citizens of the District in accordance with the authority granted and duties defined in Education Code Section 70902.

The Board is committed to fulfilling its responsibilities to:

- Represent the public interest
- Establish policies that define the institutional mission and set prudent, ethical, and legal standards for college operations
- Hire and evaluate the Superintendent/President
- Delegate power and authority to the Superintendent/President to effectively lead the District
- Assure fiscal health and stability
- Monitor institutional performance and educational quality
- Advocate and protect the District

DUTIES OF THE BOARD OF TRUSTEES

The duties and responsibilities of the Board of Trustees will be as follows:

- To select, appoint, and dismiss the Superintendent/President of the District.
- To determine the broad general policies which will govern the operation of the District.
- To adopt policies and procedures for the shared governance of the District and to review them periodically.
- To approve the annual budget.
- To approve the expenditure of all funds.
- To appoint or dismiss employees upon the recommendation of the Superintendent/President of the district.
- To fix the rate of compensation for all employees, and to review all salary schedules annually.
- To rule upon recommendations of the Superintendent/President on site utilization and physical plant development.
To rule upon recommendations of the Superintendent/President on matters of capital outlay with references to buildings, major improvements, and equipment.

- To rule upon recommendations of the Superintendent/President on matters of repairs and maintenance of the buildings, grounds, and equipment.
- To require and consider reports from the Superintendent/President concerning the program and conditions of the college.
- To consider and pass upon the curricular offerings of the college upon the recommendations of the Academic Senate and Superintendent/President.
- To consider and pass upon the annual calendar.
- To consider and pass upon the recommendations of the Superintendent/President in all matters of policy pertaining to the welfare of the college.
- To provide for the establishment of the necessary procedures to secure proper accounting of receipts and disbursements of all funds under the jurisdiction and control of the District.
- To provide for the annual audit of all funds of the District.
- To consider communications and requests from citizens or organizations on matters of policy and management.
- To establish citizen advisory committees and curricular or career and technical education advisory committees, and to approve the memberships of such committees.
- To serve as a court for final appeal for students, employees, and citizens of the District.

References: Education Code Section 70902;
WASC/ACCJC Accreditation Standard IV

Adopted: 6/18/91	Revised: 5/16/95
Revised: 8/18/92	Revised: 3/19/96
Revised: 4/20/93	Revised: 4/21/98
Revised: 4/26/94	Revised: 6/20/00
Revised: 11/22/94	Revised: 10/21/14
Revised: 3/21/95	Reviewed: 9/8/20



**Allan Hancock Joint Community College District
Board Policy
Chapter 2 – Board of Trustees**

BP 2210 OFFICERS

At the annual organizational meeting, the Board of Trustees shall elect from among its members a President and Vice-President of the Board.

The terms of officers shall be for one year.

OFFICERS

The officers of the Board will be as follows:

President

Vice-President

The Superintendent/President shall act as Secretary to the Board of Trustees

Duties of the President of the Board of Trustees

The duties of the President of the Board of Trustees will be as follows:

- To preside at all meetings of the Board.
- To appoint or provide for the election of all Board committees.
- To call emergency and special meetings as required by law.
- To consult with the Superintendent/President on Board meeting agendas.
- To communicate with individual Board members about their responsibilities.
- To participate in the orientation process for new Board members.
- To assure Board compliance with policies on board education, self-evaluation, and Superintendent/President's evaluation.
- To represent the Board at official events or ensure Board representation.
- To perform such other duties as may be prescribed by law or by action of the Board.

The President of the Board of Trustees has the right to vote on all issues and to participate in the discussions. The President shall sign all Board approved contracts, agreements, deeds, leases, plans and specifications for new building construction, remodeling, and all other legal documents except those authorized by the Board to be signed by an officer, agent or employee of the District.

In case of the absence of the President, it shall be the duty of the Vice-President to perform all the duties of the President. In the case of the resignation or disability of the President, the Vice-President shall preside until a president has been elected and qualified.

Duties of the Secretary to the Board

The major duties and responsibilities of the Secretary to the Board will be as follows:

- To notify members of the Board of all regular, special, emergency, and adjourned meetings.
- To prepare and post Board meeting agendas.
- To prepare minutes of Board meetings for adoption.
- To attend all Board meetings and closed sessions, unless excused by the Board President and in such cases to assign a designee.
- To furnish Board members with an agenda of principal items of business at least 72 hours in advance of meetings.
- To have recorded the minutes of the meetings of the Board and transmit a copy of the minutes of the previous meeting to each member of the Board before each ensuing meeting.
- To have charge of all records, proceedings, and documents of the Board.
- To conduct the official correspondence of the Board.
- To certify as legally required all Board actions.
- To sign and execute employee contracts, interdistrict agreements, and any other official documents authorized by the Board.

The Board does not have an official system of rotation of officers; it elects the officers each year from among all its members.

Reference: Education Code Section 72000

Adopted: 6/18/91	Revised: 3/19/96
Revised: 8/18/92	Revised: 4/21/98
Revised: 4/20/93	Revised: 6/20/00
Revised: 4/26/94	Revised: 10/21/14
Revised: 11/22/94	Reviewed: 9/8/20
Revised: 3/21/95	
Revised: 5/16/95	



**Allan Hancock Joint Community College District
Board Policy
Chapter 2 – Board of Trustees**

BP 2220 COMMITTEES OF THE BOARD

The Board of Trustees may, by action, establish committees that it determines are necessary to assist the Board in its responsibilities. Any committee established by Board action shall comply with the requirements of the Brown Act and with these policies regarding open meetings.

Board committees that are composed solely of less than a quorum of members of the Board that are advisory are not required to comply with the Brown Act, or with these policies regarding open meetings, unless they are standing committees.

Board committees that are only advisory have no authority or power to act on behalf of the Board. Findings or recommendations shall be reported to the Board for consideration.

Reference: Government Code Section 54952

Adopted: 2/17/15

Reviewed: 9/8/20



**Allan Hancock Joint Community College District
Board Policy
Chapter 2 – Board of Trustees**

BP 2305 ANNUAL ORGANIZATIONAL MEETING

The Board of Trustees will hold an annual organizational meeting within a 15-calendar-day period commencing on the first Friday in December. This calendar-day period applies to both election and non-election years. The purpose of the annual organizational meeting is to elect officers and conduct any other business as required by law or determined by the Board.

At the annual meeting, the Board shall organize and elect from its members a President, Vice-President and may elect an ex-officio Secretary. The Superintendent/President of the District will serve as the secretary to the Board.

All elections shall be by roll call vote. The affirmative vote of at least three members of the Board shall be necessary to elect an officer.

Reference: Education Code Section 72000(c)(2)(A)

Adopted: 6/18/91	Revised: 5/16/95
Revised: 8/18/92	Revised: 3/19/96
Revised: 4/20/93	Revised: 4/21/98
Revised: 4/26/94	Revised: 6/20/00
Revised: 11/22/94	Revised: 10/21/14
Revised: 3/21/95	Reviewed: 9/8/20



**Allan Hancock Joint Community College District
Board Policy
Chapter 2 – Board of Trustees**

BP 2315 CLOSED SESSIONS

Closed sessions of the Board shall only be held as permitted by applicable legal provisions including but not limited to the Brown Act, California Government Code, and California Education Code. Matters discussed in closed session may include:

- the appointment, employment, evaluation of performance, discipline, dismissal, or release of a public employee;
- charges or complaints brought against a public employee by another person or employee, unless the accused public employee requests that the complaints or charges be heard in an open session. The employee shall be given at least twenty-four (24) hours written notice of the closed session.
- advice of counsel on pending litigation, or the initiation of litigation, as defined by law;
- consideration of tort liability claims as part of the District's membership in any joint powers agency formed for purposes of insurance pooling;
- real property transactions;
- threats to public security;
- review of the District's position regarding labor negotiations and giving instructions to the District's designated negotiator;
- discussion of student disciplinary action, with final action taken in public;
- conferring of honorary degrees;
- consideration of gifts from a donor who wishes to remain anonymous; and
- consideration of its response to a confidential final draft audit report from the Bureau of State Audits;
- to receive, confidentially discuss, and learn about cybersecurity risks, vulnerabilities, and threats facing the District.

The agenda for each regular or special meeting shall contain information regarding whether a closed session will be held and shall identify the topics to be discussed in any closed session in the manner required by law.

After any closed session, the Board shall reconvene in open session before adjourning and shall announce any actions taken in closed session and the vote of every member present.

All matters discussed or disclosed during a lawfully held closed session, and all notes, minutes, records or recordings made of such a closed session, are confidential and shall remain confidential unless and until required to be disclosed by action of the Board or by law.

A person may not disclose confidential information that has been acquired by being present in a closed session to a person not entitled to receive it, unless the legislative body authorizes disclosure of that confidential information. Measures for addressing disclosure of confidential information are contained in Government Code Section 54963.

If any person requests an opportunity to present complaints to the Board about a specific employee, such complaints shall first be presented to the Superintendent/ President.

Notice shall be given to the employee against whom the charges or complaints are directed. If the complaint is not resolved at the administrative level, the matter shall be scheduled for a closed session of the Board. The employee shall be given at least twenty-four (24) hours written notice of the closed session, and shall be given the opportunity to request that the complaints be heard in an open meeting of the Board.

References: Education Code Section 72122;
Government Code Sections 54954.5, 54956.8, 54956.9, 54957, 54957.1, 54957.6, ~~54963~~, 11125.4

Adopted: 11/16/04
Revised: 4/16/13
Revised: 10/21/14

Revised: 7/9/19
Reviewed: 9/8/20



**Allan Hancock Joint Community College District
Board Policy
Chapter 2 – Board of Trustees**

BP 2320 SPECIAL AND EMERGENCY MEETINGS

Special meetings may from time to time be called by the President of the Board or by a majority of the members of the Board. Notice of such meetings shall be posted at least 24 hours before the time of the meeting, and shall be noticed in accordance with Brown Act. No business other than that included in the notice may be transacted or discussed.

Emergency meetings may be called by the President of the Board when prompt action is needed because of actual or threatened disruption of public facilities under such circumstances as are permitted by the Brown Act, including work stoppage, crippling disasters, and other activity that severely impairs public health or safety.

No closed session shall be conducted during an emergency meeting, except as provided for in the Brown Act to discuss a dire emergency.

The Superintendent/President shall be responsible to ensure that notice of such meetings is provided to the local news media as required by law.

References: Education Code Section 72129;
Government Code Sections 54956, 54956.5, and 54957

Adopted: 10/21/14

Reviewed: 9/8/20



**Allan Hancock Joint Community College District
Board Policy
Chapter 2 – Board of Trustees**

BP 2330 QUORUM AND VOTING

A quorum of the Board of Trustees shall consist of three members.

The Board shall act by majority vote of all of the membership of the Board, except as noted below.

No action shall be taken by secret ballot. The Board will publicly report any action taken in open session and the vote or abstention of each individual member present.

The following actions require a two-thirds majority of all members of the Board:

- Resolution of intention to sell or lease District real property, which is not or will not be needed by the District for school classroom (except where a unanimous vote is required);
- Resolution of intention to dedicate or convey an easement;
- Resolution authorizing and directing the execution and delivery of a deed;
- Action to declare the District exempt from the approval requirements of a planning commission or other local land use body;
- Appropriation of funds from an undistributed reserve;
- Resolution to condemn real property.
- Resolution to pursue the authorization and issuance of bonds pursuant to paragraph (3) of subdivision (b) of Section 1 of Article XIII A of the California Constitution and subdivision (b) of Section 18 of Article XVI of the California Constitution.

The following actions require a unanimous vote of all members of the Board:

- Resolution authorizing a sale or lease of District real property to the state, any county, city, or to any other school or community college district;
- Resolution authorizing lease of District property under a lease for the production of gas

References: Education Code Sections 15266, 72000 subdivision (d)(3), 81310 et seq., 813360, 81365, 81511, and 81432;
Government Code Section 53094;
Code of Civil Procedure Section 1245.240

Adopted: 10/21/14
Revised: 7/9/19

Reviewed: 9/8/20
Revised: 11/21/23



**Allan Hancock Joint Community College District
Board Policy
Chapter 2 – Board of Trustees**

BP 2350 SPEAKERS

Persons may speak to the Board of Trustees either on an agenda item or on other matters of interest to the public that are within the subject matter jurisdiction of the Board.

Oral presentations relating to a matter on the agenda, including those on the consent agenda, shall be heard before a vote is called on the item.

Persons wishing to speak to matters not on the agenda shall do so at the time designated at the meeting for public comment.

Those wishing to speak to the Board are subject to the following:

- The President of the Board may rule members of the public out of order if their remarks do not pertain to matters that are within the subject matter jurisdiction of the Board or if their remarks are unduly repetitive.
- Employees who are members of a bargaining unit represented by an exclusive bargaining agent may address the Board under this policy, but may not attempt to negotiate terms and conditions of their employment. This policy does not prohibit any employee from addressing a collective bargaining proposal pursuant to the public notice requirements of Government Code Section 3547 and the policies of this Board implementing that section.
- They shall complete a written request to address the Board at the beginning of the meeting at which they wish to speak.
- The request shall include the person's name and name of the organization or group represented, if any, and a statement noting the agenda item or topic to be addressed.
- No member of the public may speak without being recognized by the President of the Board.
- The leading speaker from the audience on each side of the issue will be limited to five minutes. Additional speakers are limited to two minutes. This time limit may be waived by the President of the Board.
- Each speaker coming before the Board is limited to one presentation per specific agenda item before the Board, and to one presentation per meeting on non-agenda matters.

References: Education Code Section 72121.5;
Government Code Sections 54950 et seq.

Adopted: 2/17/15

Reviewed: 9/8/20



**Allan Hancock Joint Community College District
Board Policy
Chapter 2 – Board of Trustees**

BP 2360 MINUTES

The Superintendent/President shall cause minutes to be taken of all meetings of the Board of Trustees. The minutes shall record all actions taken by the Board, including the name of the person making and seconding a motion, and the vote. Voting will be by voice. A member voting against a proposition may state reasons and may have them recorded in the minutes if so requested at the time the vote is taken.

Until the Board adopts such minutes, they shall be considered unadopted minutes.

The minutes shall be kept by the Secretary to the Board as a permanent official record of District action. The minutes are public records and shall be made available to the public. If requested, the minutes shall be made available in appropriate alternative formats so as to be accessible to persons with a disability.

References: Education Code 72121(a);
Government Code Section 54957.5

Adopted: 4/16/13
Revised: 10/21/14

Reviewed: 9/8/20



**Allan Hancock Joint Community College District
Board Policy
Chapter 2 – Board of Trustees**

BP 2365 RECORDING

Any audio or video recording of an open and public Board of Trustees Meeting made by or at the direction of the Board shall be subject to inspection by members of the public in accordance with the California Public Records Act, Government Code Sections 7920.000 et seq. The Superintendent/President is directed to enact administrative procedures to ensure that any such recordings are maintained for at least thirty days following the taping or recording.

Persons attending an open and public meeting of the Board may, at their own expense, record the proceedings with an audio or video tape recording or a still or motion picture camera or may broadcast the proceedings. However, if the Board finds by a majority vote that the recording or broadcast cannot continue without noise, illumination, or obstruction of view that constitutes or would constitute a persistent disruption of the proceedings, any such person shall be directed by the President of the Board to stop.

References: Education Code Section 72121(a);
Government Code Sections 7920.000 et seq., 54953.5, and 54953.6

**Adopted: 2/17/15
Reviewed: 9/8/20**

Revised: 11/21/23



**Allan Hancock Joint Community College District
Board Policy
Chapter 2 – Board of Trustees**

BP 2410 BOARD POLICIES AND ADMINISTRATIVE PROCEDURES

The Board of Trustees may adopt such policies as are authorized by law or determined by the Board of Trustees to be necessary for the efficient operation of the District. Board policies are intended to be statements of intent by the Board of Trustees on a specific issue within its subject matter jurisdiction.

The policies have been written to be consistent with provisions of law, but do not encompass all laws relating to District activities. All District employees are expected to know of and observe all provisions of law pertinent to their job responsibilities.

Policies of the Board of Trustees may be adopted, revised, added to, or amended at any meeting of the Board by a majority vote of the members of the Board. Proposed changes or additions shall be introduced not less than one meeting prior to the meeting at which action is recommended.

Administrative procedures are to be issued by the Superintendent/President as statements of method to be used in implementing board policy. Such administrative procedures shall be consistent with the intent of board policy. Administrative procedures may be revised as deemed necessary by the Superintendent/President. Before review by the Board, representatives from the faculty, classified staff, administration and students as members of the College Council, shall have an opportunity to review any administrative procedure change or suspension and to make their views known. Participation of college constituencies shall be consistent with Board Policy 2510 Shared Governance and Administrative Procedure 2510 Shared Governance related to shared governance. The Board of Trustees reserves the right to direct revisions of the administrative procedures should they, in the Board of Trustee's judgment, be inconsistent with the Board of Trustee's own policies.

In addition, the following documents, as approved by the Board of Trustees, are considered a part of these policies and procedures, and should be consulted in conjunction with the related sections of this manual:

- College Catalog
- Agreement Between the District and California School Employees Association Allan Hancock College Chapter #251

- Agreement Between the District and the Faculty Association of Allan Hancock College
- Agreement Between District and California Federation of Teachers/Part-Time Faculty Association of Allan Hancock College Local 6185
- Guidelines for Student Conduct, Disciplinary Action and Procedural Fairness
- Student Rules and Regulations
- Injury and Illness Prevention Program

Should a statute or administrative code section of the State of California be added, repealed or amended, or should a court decision or an opinion of the County Counsel or the Attorney General of the State of California make changes in any of the policies of the Board of Trustees, or in the administrative procedures of this District, the policies and procedures shall be considered to be automatically amended to comply. The Board shall be notified of these changes and their effect on the District.

Should a conflict exist between the publications cited in paragraph five of this page and the policies contained herein, said policies will prevail.

The Superintendent/President shall make copies readily available of all policies and administrative procedures to District employees and to each member of the Board of Trustees.

Policy Changes

The policies adopted by the Allan Hancock College Board of Trustees have been written to be consistent with the provisions of law but do not encompass all laws relating to the District's activities. Any change in policy or suspension of policy, other than those within the scope of bargaining, shall first be proposed for information at any meeting of the Board of Trustees, and may not be acted upon until the next meeting of the Board of Trustees. Before action is taken by the Board, representatives from the faculty, the classified staff, the administration and students as members of the College Council, shall have an opportunity to review any policy change or policy suspension and to make their views and recommendations known. Participation of college constituencies shall be consistent with Board Policy 2510 Shared Governance and Administrative Procedure 2510 Shared Governance related to shared governance.

When policy is suspended or amended it must be by a majority vote of the entire Board.

Such suspension or amendment shall not become effective for one week, in order for those affected by the change to become acquainted with the change and comply.

The Superintendent/President shall notify employees of changes in policy. The Superintendent/President shall make readily available copies of all policies and administrative procedures to District employees and to each member of the Board of Trustees.

References: Education Code 70902
ACCJC Accreditation Standard 4.4

Adopted: 3/18/83

Revised: 2/18/97

Revised: 4/16/13

Revised: 9/8/15

Reviewed: 9/8/20

Revised (reference only): 7/16/24



**Allan Hancock Joint Community College District
Board Policy
Chapter 2 – Board of Trustees**

**BP 2430 DELEGATION OF AUTHORITY TO THE
SUPERINTENDENT/PRESIDENT**

The Board of Trustees delegates to the Superintendent/President the executive responsibility for administering the policies adopted by the Board and executing all decisions of the Board requiring administrative action. The Board gives the Superintendent/President full authority to implement board policies and ensure effective operations and fulfillment of the institutional mission.

The Superintendent/President may delegate any powers and duties entrusted to him/her by the Board (including the administration of the college and centers), but will be specifically responsible to the Board for the execution of such delegated powers and duties. The Superintendent/President is empowered to reasonably interpret board policy. In situations where there is no board policy direction, the Superintendent/President shall have the power to act, but such decisions shall be subject to review by the Board. It is the duty of the Superintendent/President to inform the Board of such action and to recommend written board policy if one is required.

The Superintendent/President is expected to perform the duties contained in the Superintendent/President's job description and fulfill other responsibilities as may be determined in annual goal-setting or evaluation sessions. The job description and goals and objectives for performance shall be developed by the Board in consultation with the Superintendent/President. The Superintendent/President shall ensure that all relevant laws and regulations are complied with, and that required reports are submitted in a timely manner.

The Superintendent/President shall make available any information or give any report requested by the Board as a whole. Individual trustee requests for information shall be met if, in the opinion of the Superintendent/President, they are not unduly burdensome or disruptive to District operations. Information provided to any trustee shall be made available to all trustees. The Superintendent/President shall act as the professional advisor to the Board in policy formation. The Board delegates to the Superintendent/President the authority to supervise the general business procedures of the District to assure the proper administration of property and contracts; the budget, audit and accounting of funds; the acquisition of supplies, equipment and property; and the

protection of assets and persons. All transactions shall comply with applicable laws and regulations, and with the California Community Colleges Budget and Accounting Manual.

The Superintendent/President shall make appropriate periodic reports to the Board and shall keep the board fully advised regarding the financial status of the District.

The Board delegates authority to the Superintendent/President to authorize employment, fix job responsibilities, and perform other personnel actions provided that all federal and state laws and regulations and board policies and administrative procedures have been followed and is subject to confirmation by the Board.

References: Education Code Sections 70902(d), 72400, ~~81655, and 81656~~;
~~WASC/ACCJC Accreditation Standards IV.B.5 and IV.C.12~~ 4.5

Adopted: 8/18/09

Reviewed: 9/8/20

Revised: 4/16/13

Revised: 10/21/14



**Allan Hancock Joint Community College District
Board Policy
Chapter 2 – Board of Trustees**

BP 2431 SUPERINTENDENT/PRESIDENT SELECTION

In the case of a vacancy in the Superintendent/President's position, the Board of Trustees shall establish a search process to fill the vacancy. The process shall be fair and open and comply with relevant regulations.

References: Title 5 Sections 53000 et seq.;
ACCJC Accreditation Standards 4.5

**Adopted: 10/21/14
Reviewed: 9/8/20**

Revised (reference only): 7/16/24



**Allan Hancock Joint Community College District
Board Policy
Chapter 2 – Board of Trustees**

BP 2432 SUPERINTENDENT/PRESIDENT SUCCESSION

The Board of Trustees delegates authority to the Superintendent/President to appoint an acting Superintendent/President to serve in his/ or her absence for short periods of time, not to exceed 30 calendar days at a time.

In the absence of the Superintendent/President when an acting Superintendent/President has not been named, administrative responsibility shall reside with (in order):

Associate Superintendent/Vice President, Finance and Administrative Services

Associate Superintendent/Vice President, Academic Affairs

Associate Superintendent/Vice President, Student Services

The Board shall appoint an acting or interim Superintendent/President for periods exceeding 30 calendar days.

In the case of resignation, retirement, or death of the Superintendent/President, the Board shall establish a Superintendent/President search process. The Board may appoint an interim Superintendent/President for up to one year.

References: Ed Code Sections 70902(d); and 72400;
Title 5 Section 53021(b)(2)

Adopted: 1/21/03

Reviewed: 9/8/20

Revised: 11/16/04

Revised: 5/19/15



**Allan Hancock Joint Community College District
Board Policy
Chapter 2 – Board of Trustees**

BP 2435 EVALUATION OF THE SUPERINTENDENT/PRESIDENT

The Board shall conduct an evaluation of the Superintendent/President at least annually. Such evaluation shall comply with any requirements set forth in the contract of employment with the Superintendent/President as well as this policy.

The Board shall evaluate the Superintendent/President using an evaluation process developed and jointly agreed to by the Board and the Superintendent/President.

The criteria for evaluation shall be based on Board policy, the Superintendent/ President's job description, and performance goals and objectives developed in accordance with AP 2435 titled Evaluation of the Superintendent/President.

Reference: ACCJC Accreditation Standard 4.5

Adopted: 10/21/14
Reviewed: 9/8/20

Reviewed (reference only): 7/16/24



Allan Hancock Joint Community College District
Administrative Procedure
 Chapter 2 – Board of Trustees

AP 2435 EVALUATION OF THE SUPERINTENDENT/PRESIDENT

Basis of Evaluation

The evaluation of the Superintendent/President will be based on the job description, goals and objectives of the past year, characteristics of performance, and other elements previously agreed upon. The Superintendent/President's contract shall include a provision that he/she/they will be evaluated on an annual basis. As part of the evaluation process, the Superintendent/President and the Board of Trustees shall mutually agree upon the goals and objectives to be considered for the following year. The Board of Trustees will include in the goals and objectives for the following year those items that appear to have merit for future evaluation.

Evaluation Process

The annual evaluation shall be scheduled to coincide with the conclusion of the Superintendent/President's contract year. The evaluation forms will be distributed to the members of the Board of Trustees one month prior to the end of the contract year. The final evaluation will be based upon progress toward goals and objectives, a composite of the evaluation forms completed by individual members of the Board of Trustees, and the Superintendent/President's self-evaluation.

The Board of Trustees, as a whole, will meet with the Superintendent/President to discuss the final evaluation. A copy of the final evaluation shall be furnished to the Superintendent/President prior to that meeting. The evaluation shall include a discussion of both strengths and weaknesses. Each judgment will be based upon an objective review derived from an examination of available information. A final written summary evaluation shall be prepared by the Board of Trustees. A signed copy will be retained by the Superintendent/President and one will be placed in the Superintendent/ President's personnel file.

A. Purpose

Employee evaluation has as its primary purpose the improvement of performance. For maximum benefit to both the individual and the District, employee evaluation will be conducted in a positive manner. Evaluation of the Superintendent/President will be an ongoing process. The process and criteria used will be understood by

and mutually acceptable to the Board of Trustees and to the Superintendent/President.

B. Objectives

1. Assess how well the Superintendent/President is fulfilling leadership and management responsibilities.
2. Evaluate accomplishments related to job description and annual goals and objectives.
3. Determine specific improvement goals and objectives for the Superintendent/President.
4. Give the Superintendent/President support and guidance through constructive information on past performance.
5. Foster effective communication between the Board and Superintendent/President.

C. Rating System

Quantifiable grading system

Reference: ACCJC Accreditation Standard 4.5

Approved: 8/19/14
Reviewed: 1/14/20

Revised: 12/15/20
Revised (reference only): 7/16/24



**Allan Hancock Joint Community College District
Board Policy
Chapter 2 – Board of Trustees**

BP 2510 SHARED GOVERNANCE

Allan Hancock College is strongly committed to the concept and the practice of shared governance as a process for institutional decision making. Shared governance is the meaningful involvement of those affected by decisions in the decision-making process in a climate of mutual trust and respect. In order to implement shared governance, the District subscribes to the following principles.

1. Faculty, administrators, classified staff, and students each possess a special knowledge and expertise that will enhance the quality of decisions.
2. All parties involved must work for the good of the institution in fulfilling its mission.
3. The welfare of students is our most important goal and all parties must be committed to the institution's primary mission which is the highest possible quality of education and service to students.
4. The decision-making process depends upon open communication and full sharing of information with all parties involved.
5. While shared governance is time consuming and requires a high level of commitment on the part of all parties involved, the benefits, including greater understanding and acceptance of decisions, are worthy of the effort.
6. Consensus will not always be possible and the governing board, as the entity holding the institution in trust for the community, has the ultimate responsibility to act. However, such action should be taken only after every effort has been made to resolve the matter collegially and should only occur in unusual circumstances and for compelling reasons. When such conditions exist the Board's decision will be accompanied by a written explanation to the parties involved.
7. In order for shared governance to work, the most critical component is mutual trust.

The Board is the ultimate decision-maker in those areas assigned to it by state and federal laws and regulations. In executing that responsibility, the Board is committed to its obligation to ensure that appropriate members of the District participate in developing recommended policies for Board action and administrative procedures for Superintendent/President action under which the District is governed and administered.

Each of the following shall participate as required by law in the decision-making processes of the District:

Academic Senate(s) (Title 5 Sections 53200-53206)

The Board or its designees will consult collegially with the Academic Senate, as duly constituted with respect to academic and professional matters, as defined by law. Procedures to implement this section are developed collegially with the Academic Senate.

Staff (Title 5 Section 51023.5)

Staff shall be provided with opportunities to participate in the formulation and development of District policies and procedures that have a significant effect on staff. The opinions and recommendations of the faculty association, CSEA, management, classified senate, supervisory/confidential will be given every reasonable consideration.

Students (Title 5 Section 51023.7)

The Associated Students shall be given an opportunity to participate effectively in the formulation and development of district policies and procedures that have a significant effect on students, as defined by law. The recommendations and positions of the Associated Students will be given every reasonable consideration. The selection of student representatives to serve on District committees or task forces shall be made after consultation with the Associated Students.

Except for unforeseeable emergency situations, the Board shall not take any action on matters subject to this policy until the appropriate constituent group or groups have been provided the opportunity to participate.

Nothing in this policy will be construed to interfere with the formation or administration of employee organizations or with the exercise of rights guaranteed under the Educational Employment Relations Act, Government Code Sections 3540 et seq.

References: Education Code Section 70902(b) (7);
 Title 5 Sections 53200 et seq. (Academic Senate), 51023.5 (Staff), and
 51023.7 (Students);
 ACCJC Accreditation Standard 4.2 and 4.3

Adopted: No date

Revised: 9/8/15

Reviewed: 9/8/20

Revised (reference only): 7/16/24



Allan Hancock Joint Community College District
Administrative Procedure
 Chapter 2 – Board of Trustees

AP 2510 SHARED GOVERNANCE

We believe the following structure is essential to effective implementation of shared governance.

- A. Each constituency which has responsibility and/or expertise in an area shall participate in the development of policies and procedures for that area.
- B. All standing and ad hoc committees shall be structured to include appropriate representation by faculty, administration, classified staff, and students based on the relevance of matters considered by that committee to each constituency.
- C. Appointment to all shared governance committees and councils shall be based on the recommendation of the appropriate organization: faculty representatives from Academic Senate, administrative representatives from the Administrative Council and President's Cabinet, classified staff representatives from CSEA and non-represented classified confidential/supervisory staff, and student representatives from the Student Council of the Associated Student Body.
- D. The college recognized the Executive Committee of the Academic Senate as the body which represents the faculty in collegial governance for academic and professional matters. Based on Education Code Section 53200, we recognize that the definition of academic and professional matters includes, but is not limited to, the ten areas listed below.

In the following areas the Board of Trustees or its designees shall rely primarily upon the advice and judgment of the Academic Senate.

1. Curriculum, including establishing prerequisites and placing courses within disciplines
2. Degree and certificate requirements
3. Grading Policies
4. Educational program development
5. Faculty roles and involvement in accreditation processes including self-study and annual reports
6. Policies for faculty professional development activities

In the following areas the Board of Trustees or its designees shall reach mutual agreement with the Academic Senate:

1. Standards or policies regarding student preparation and success;
2. District and college governance structures as related to faculty roles;
3. Processes for program review;
4. Processes for institutional planning and budget development;

In these and other academic and professional matters mutually agreed upon, the Board of Trustees, or its designees, shall rely primarily upon the advice and judgment of, or mutual agreement with, the Academic Senate.

Upon request of the Academic Senate the administration shall confer and collaborate with senate representatives regarding recommendations or proposals by the senate. If the parties involved do not reach consensus, the senate may present its views to the Board and the Board shall consider and respond to those views. Likewise, senate representatives have the responsibility when requested to confer and collaborate with the administration and to respond to their proposals and recommendations.

Student Role in Governance

- E. Students shall be allowed the opportunity for reasonable representation in the arenas that discuss and set standards in areas that include the following topics:
 1. Grading policies;
 2. Codes of student conduct;
 3. Academic disciplinary policies;
 4. Curriculum development;
 5. Course or programs which should be initiated or discontinued;
 6. Processes for institutional planning and budget development;
 7. Standards and policies regarding student preparation and success;
 8. Student services planning and development;
 9. Student fees within the authority of the district to adopt;
 10. Any other District and college policy, procedure, or related matter that the Board of Trustees determines will have a significant effect on students.

- F. The Board of Trustees shall give reasonable consideration to recommendations and positions developed by students regarding District and college policies and procedures pertaining to the hiring and evaluation of faculty, administration, and staff.

- G. The administration and Board of Trustees shall provide an opportunity for student input into the decision-making process on matters that have significant or direct effect on students before the decision is made or action is taken, except in unforeseen or emergency situations.

- H. The Student Council of the Associated Student Body is the officially recognized body representing the college's student population enrolled in credit classes.
- I. Students who participate in college governance shall be officially appointed by the chief executive officer of the Student Council of the Associated Student Body.
- J. Students who participate in college governance are accountable to the Student Council of the Associated Student Body and should present reports to that body on a regular basis.
- K. Student participants should make an effort to seek the perspective and positions of the student body at large and should make known to the student body the pertinent information discussed at the governance meeting.
- L. The college should provide appropriate opportunities to strengthen student knowledge and understanding of governance issues in order to foster student preparedness and self-confidence, and to enhance student credibility.

References: Education Code Section 70902(b)(7);
 Title 5 Sections 53200 et seq. (Academic Senate), 51023.5 (Staff), and
 51023.7 (Students);
 ACCJC Accreditation Standard 4.2 and 4.3

Approved: 2/18/93
Revised: 4/26/94
Revised: 2/18/97
Revised: 8/11/15

Reviewed: 1/14/20
Revised (reference only): 7/16/24



**Allan Hancock Joint Community College District
Board Policy
Chapter 2 – Board of Trustees**

BP 2610 PRESENTATION OF INITIAL COLLECTIVE BARGAINING PROPOSALS

The Superintendent/President is directed to enact administrative procedures that assure compliance with the requirements of Government Code Section 3547 regarding the presentation to the Board of initial proposals for collective bargaining.

Collective bargaining begins when either an exclusive representative or the District itself presents an initial proposal for consideration in accordance with the following timelines:

The duty to meet and negotiate in good faith requires the parties to begin negotiations prior to the adoption of the final budget for the ensuing year sufficiently in advance of such adoption date so that there is adequate time for agreement to be reached, or for the resolution of an impasse.

Reference: Government Code Section 3547

Adopted: 5/19/15

Reviewed: 9/8/20



**Allan Hancock Joint Community College District
Board Policy
Chapter 2 – Board of Trustees**

BP 2715 CODE OF ETHICS/STANDARDS OF PRACTICE

The Board of Trustees of the Allan Hancock Joint Community College District (hereafter called the District) derives its authority from the state constitution and acts of the state legislature. It is the goal of the Board to create an atmosphere in which learning can flourish by promoting a healthy working relationship with the Superintendent/ President and the college community through mutual trust and support.

The governing board functions effectively as a collective entity to promote the institution's values and mission and fulfill its fiduciary responsibilities. The governing board demonstrates an ability to self-govern in adherence to its bylaws and expectations for best practices in board governance.

The Board maintains high standards of ethical conduct for its members. Members of the Board are responsible to:

1. Hold the educational welfare of the district's students as his/her primary concern and assure an equal opportunity for the highest quality education possible within the fiscal limitations of the district.
2. Accept the concept that each board member is only one member of the educational team and that the strength and effectiveness of the board is as a board; no member or committee shall act in place of the board.
3. Recognize that the primary responsibility of the board is to represent the entire community and that each member must maintain his/her independent judgment accordingly, refusing to surrender that independent judgment to individuals, special interest or partisan political groups.
4. Make a commitment to the responsibilities one assumes when elected as a trustee including becoming knowledgeable of and supporting the mission and philosophy of the district, becoming informed concerning fiscal and legal responsibilities, and committing time and energy to discharging the duties of being a trustee by supporting the interest of the college internally as well as in the community.

5. Recognize and adhere to the distinction between the board making policy and the administration carrying out policy by delegating authority to the superintendent/president, as the board's executive, while confining board action to policy determination, planning, overall approval and evaluation, and maintenance of the fiscal stability of the district.
6. Comply with the requirements of the Brown Act while maintaining confidentiality of privileged information.
7. Respect the opinions of fellow board members and abide by the principle of majority rule.
8. Ensure an atmosphere in which controversial issues can be presented fairly and in which the dignity of each individual is protected.
9. Recognize that participation of any board member in actions involving possible conflict of interest is precluded.
10. Respect the office and in no way misuse the power inherent in the office.

Charges by any person that a Board member has violated laws and regulations governing Board behavior or the Board's code of ethics shall be directed to the Board President or the Board of Trustees. The Board President shall establish an ad hoc committee to examine the charges and recommend further courses of action to the Board. If the President of the Board is perceived to have violated the code, the Vice President of the Board is authorized to pursue resolution.

Reference: ~~WASC/ACCJC~~ Accreditation Standard IV-C-114.6

Adopted: 11/19/91
Revised: 1/19/10
Revised: 5/19/15

Reviewed: 9/8/20



**Allan Hancock Joint Community College District
Board Policy
Chapter 2 – Board of Trustees**

BP 2716 POLITICAL ACTIVITY – DISTRICT FUNDS

Members of the Board of Trustees shall not use District funds, services, supplies, or equipment to urge the passage or defeat of any ballot measure or candidate, including, but not limited to, any candidate for election to the Board.

Initiative or referendum measures may be drafted on an area of legitimate interest to the District. The Board may by resolution express the Board's position on ballot measures. Public resources may be used only for informational efforts regarding the possible effects of District bond issues or other ballot measures.

References: Education Code Sections 7054, 7054.1, and 7056;
Government Code Section 8314

Adopted: 2-17-15

Reviewed: 9/8/20



**Allan Hancock Joint Community College District
Board Policy
Chapter 2 – Board of Trustees**

BP 2717 PERSONAL USE OF PUBLIC RESOURCES

No member of the Board of Trustees shall use or permit others to use public resources, except that which is incidental and minimal, for personal purposes or any other purpose not authorized by law.

References: Government Code Section 8314;
Penal Code Section 424

Adopted: 2-17-15

Reviewed: 9/8/20



**Allan Hancock Joint Community College District
Board Policy
Chapter 2 – Board of Trustees**

BP 2730 BOARD MEMBER HEALTH BENEFITS

Members of the Board of Trustees shall be permitted to participate in the District's health benefit programs. The benefits of members of the Board through the District's health benefits programs shall not be greater than the most generous schedule of benefits being received by any category of non-safety employee of the District.

Former members of the Board may continue to participate in the District's health benefits programs upon leaving the Board if the following criteria are met: the member must have begun service on the Board after January 1, 1981; the member must have been first elected to the Board before January 1, 1995; and the member must have served at least 12 years. All other former Board members may continue to participate in the District's health benefits programs on a self-pay basis.

The District shall provide health insurance coverage in Board-approved group insurance plans for active Board members, with employee premiums to be paid by Board members the District. All active Board members must be enrolled in a health plan. Only Board members who are covered on another group health insurance plan as the employee or retiree, but not as the dependent of a spouse, may decline coverage. Proof of coverage will be required if participation is declined.

The District shall also provide optional dental insurance coverage in Board-approved insurance plans for active Board members, with employee premiums paid by Board members.

Board members who have completed one or more terms of office may continue coverage upon retirement from the Board for a period not to exceed 18 months or until attaining age 65 or eligibility for Medicare. Employee premiums will be paid by the Board member.

The Board will review this policy prior to the close of each fiscal year.

References: Government Code Sections 53201 and 53208.5

Adopted: 9/15/98
Revised: 9/12/00
Revised: 9/8/15

Reviewed: 9/8/20



Allan Hancock Joint Community College District
Administrative Procedure
Chapter 2 – Board of Trustees

AP 2735 BOARD MEMBER TRAVEL

Board members including the Student Trustee are encouraged to participate in activities that increase and enhance their understanding of the community college mission and the role of trustees on a governing board, including serving as advocates for, and representatives of the college. When such participation occurs, all Board members are encouraged to report on their activities to their fellow trustees, at a regular Board meeting.

Reference: Education Code Section 72423

Approved: 4/21/15

Revised: 1/14/20



**Allan Hancock Joint Community College District
Board Policy
Chapter 2 – Board of Trustees**

BP 2740 BOARD EDUCATION

The Board of Trustees is committed to its ongoing development as a Board and to a trustee education program that includes new trustee orientation.

To that end, the Board will engage in study sessions, provide access to reading materials, and support conference attendance and other activities that foster trustee education.

ORIENTATION OF NEW BOARD MEMBERS

The Superintendent/President and the Board President shall assist each new member-elect to understand the Board's functions, policies and procedures, and financial affairs. The following methods shall be employed:

- The electee will be provided with material to assist in the fulfillment of Board responsibilities.
- The electee shall be invited to attend Board meetings.
- The incoming member shall be invited to meet with the Superintendent/President and Board President to discuss services performed for the Board.

Orientation of Board members shall be an ongoing process in order for them to be informed about college programs and services.

Reference: ACCJC Accreditation Standard 4

Adopted: 6/18/91	Revised: 3/19/96
Revised: 8/18/92	Revised: 4/21/98
Revised: 4/20/93	Revised: 6/20/00
Revised: 4/26/94	Revised: 5/19/15
Revised: 11/22/94	Reviewed: 9/8/20
Revised: 3/21/95	Revised (reference only): 7/16/24
Revised: 5/16/95	



**Allan Hancock Joint Community College District
Board Policy
Chapter 2 – Board of Trustees**

BP 2745 BOARD SELF-EVALUATION

The Board of Trustees is committed to assessing its own performance as a Board in order to identify its strengths and areas in which it may improve its functioning.

An annual self-evaluation will be conducted by the Board of Trustees.

To that end, the Board has established the following processes:

- The Board shall determine the instrument or process to be used in Board self-evaluation. Any evaluation instrument shall incorporate criteria contained in these Board policies regarding Board operations, as well as criteria defining Board effectiveness promulgated by recognized practitioners in the field.
- The process for evaluation shall be recommended to and approved by the Board.
- If an instrument is used, all board members will be asked to complete the evaluation instrument and submit them to the Board Secretary.
- A summary of the evaluations will be presented and discussed at a Board session scheduled for that purpose. The results will be used to identify accomplishments in the past year and goals for the following year.

Reference: ACCJC Accreditation Standard 4

Adopted: 6/18/91	Revised: 3/19/96
Revised: 8/18/92	Revised: 4/21/98
Revised: 4/20/93	Revised: 6/20/00
Revised: 4/26/94	Revised: 10/21/14
Revised: 11/22/94	Reviewed: 9/8/20
Revised: 3/21/95	Revised (reference only): 7/16/24
Revised: 5/16/95	



**Allan Hancock Joint Community College District
Board Policy
Chapter 2 – Board of Trustees**

BP 2750 BOARD MEMBER ABSENCE FROM THE STATE

No member of the Board of Trustees shall be absent from the state for more than 60 days, except in any of the following situations:

- Upon business of the District with the approval of the Board.
- With the consent of the Board for an additional period not to exceed a total absence of 90 days. In the case of illness or other urgent necessity, and upon a proper showing thereof, the time limited for absence from the state may be extended by the Board.
- For federal military deployment, not to exceed an absence of a total of six months, as a member of the Armed Forces of the United States or the California National Guard. If the absence of a member of the Board pursuant to this subdivision exceeds six months, the Board may approve an additional six-month absence upon a showing that there is a reasonable expectation that the member will return within the second six-month period, and the Board may appoint an interim member to serve in his/her absence. If two or more members of the Board are absent by reason of the circumstances described in this subdivision, and those absences result in the inability to establish a quorum at a regular meeting, the Board may immediately appoint one or more interim members as necessary to enable the Board to conduct business and discharge its responsibilities.
- The term of an interim member of the Board appointed as set forth above may not extend beyond the return of the absent member, nor may it extend beyond the next regularly scheduled election for that office.

Reference: Government Code Section 1064

Adopted: 5/19/15

Reviewed: 9/8/20

INFORMATION ITEM

To: Board of Trustees	Date: July 15, 2025
From: Superintendent/President	
Subject: Board Self-Evaluation	Item Number: 10.B.
Institutional Goal: Accreditation Standard IV	Enclosures: Page 1 of 4

BACKGROUND

Board policy 2745, Board Self-Evaluation, specifies that the board of trustees will conduct an annual self-evaluation. Each trustee received an advance copy of the self-evaluation survey for review.

Administrator Initiating Item: Kevin G. Walthers	Final Disposition:
---	--------------------

BOARD OF TRUSTEES – SELF EVALUATION Summer 2025

TRUSTEE NAME _____

Please rate your level of agreement with the following criteria:	Outstanding(3)	Good (2)	Needs Improvement(1)	Unable to Evaluate (0)
<i>I. Mission, Planning, and Policy</i>				
1. The board assures that there is an effective planning process and is appropriately involved in the process.				
2. The board regularly reviews the district’s mission and goals and monitors progress towards the goals.				
3. The board fulfills its policy role; the board’s policies are up-to-date and regularly reviewed.				
<i>II. Board-CEO Relations</i>				
4. The board maintains an excellent working relationship with the CEO.				
5. The board sets clear expectations for and effectively evaluates the CEO.				
6. The board delegates authority to and supports the CEO.				
<i>III. Community Relations & Advocacy</i>				
7. Board members represent the interests of the citizens in the district.				
8. The board advocates on behalf of the college to local, state, and federal governments.				
<i>IV. Educational Programs and Quality</i>				
9. The board effectively monitors the quality and effectiveness of the educational program and services.				
10. Board members are knowledgeable about the district’s educational programs and services.				

Please rate your level of agreement with the following criteria:	Outstanding(3)	Good (2)	Needs Improvement(1)	Unable to Evaluate (0)
<i>V. Fiduciary Role</i>				
11. The board assures the fiscal stability and health of the district.				
12. The board monitors implementation of the facilities plan.				
<i>VI. Human Resources and Staff Relations</i>				
13. Board members refrain from attempting to manage employee work.				
14. The board respects faculty, staff, and student participation in college decision-making.				
<i>VII. Board Leadership</i>				
15. The board understands and fulfills its roles and responsibilities.				
16. The board expresses its authority only as a unit.				
17. The board regularly reviews and adheres to its code of ethics or standards of practice.				
18. Board members avoid conflicts of interest and the perception of such conflicts.				
<i>VIII. Board Meetings</i>				
19. Board meeting agendas provide sufficient information and time to explore and resolve key issues.				
20. The board understands and adheres to the Brown Act.				
<i>IX. Board Education</i>				
21. New members receive orientation to board roles and the institution.				
22. Board members participate in trustee development activities.				
23. The board evaluation process helps the board enhance its performance.				

 Trustee Signatures



**Allan Hancock Joint Community College District
Board Policy
Chapter 2 – Board of Trustees**

BP 2745 BOARD SELF-EVALUATION

The Board of Trustees is committed to assessing its own performance as a Board in order to identify its strengths and areas in which it may improve its functioning.

An annual self-evaluation will be conducted by the Board of Trustees.

To that end, the Board has established the following processes:

- The Board shall determine the instrument or process to be used in Board self-evaluation. Any evaluation instrument shall incorporate criteria contained in these Board policies regarding Board operations, as well as criteria defining Board effectiveness promulgated by recognized practitioners in the field.
- The process for evaluation shall be recommended to and approved by the Board.
- If an instrument is used, all board members will be asked to complete the evaluation instrument and submit them to the Board Secretary.
- A summary of the evaluations will be presented and discussed at a Board session scheduled for that purpose. The results will be used to identify accomplishments in the past year and goals for the following year.

Reference: WASC/ACCJC Accreditation Standard IV.C.10

Adopted: 6/18/91	Revised: 5/16/95
Revised: 8/18/92	Revised: 3/19/96
Revised: 4/20/93	Revised: 4/21/98
Revised: 4/26/94	Revised: 6/20/00
Revised: 11/22/94	Revised: 10/21/14
Revised: 3/21/95	Reviewed: 9/8/20

To: Board of Trustees	Date: July 15, 2025
From: Superintendent/President	
Subject: Acceptance of Employee Retirement and Resignations	Item Number: 10.C.
Institutional Goal: Accreditation Standard III	Enclosures: Page 1 of 1

BACKGROUND

The superintendent/president has accepted the following:

Resignation(s)

Employee Name	Position	Department	Effective Date	Employment Date
Badalamenti, Olivia	Teacher, Children's Center	Children's Center	05/10/25 (correct date)	04/28/25
Alvarado, Isabela	Student Resource & Support Technician	Basic Needs	07/30/25	08/01/24

Administrator Initiating Item: Ruben Ramirez	Final Disposition:
---	--------------------

To: Board of Trustees	Date:
From: Superintendent/President	July 15, 2025
Subject: First Review of K-12 CCAP Agreements with the School Districts	Item Number: 10.D.
Institutional Goal: Ed Master Plan Goal E. Transition to Transfer and/or Gainful Employment	Enclosures: Page 1 of 48

BACKGROUND

This year, Allan Hancock College will enter into new Career Access Pathways Partnership (CCAP) agreements with each of our K-12 high school partners for the purpose of offering or expanding dual enrollment opportunities, with the goal of developing seamless pathways from high school to community college for career technical education or preparation for transfer. These contracts will be in effect for three years and will replace the existing non-CCAP agreements. The governing board of each partner shall present, take comments from the public on, and approve or disapprove the dual enrollment partnership agreement at an open public meeting of the governing board. The contracts for the following school districts are presented for review and will be followed by a second review for approval to implement the contracts in fall 2025.

- Cuyama Joint Unified School District
- Gateway Community Charters

Administrator Initiating Item: Robert Curry	Final Disposition:
--	--------------------

**COLLEGE AND CAREER ACCESS PATHWAYS (CCAP)
PARTNERSHIP AGREEMENT
BETWEEN
THE ALLAN HANCOCK JOINT COMMUNITY COLLEGE DISTRICT
AND
CUYAMA JOINT UNIFIED SCHOOL DISTRICT**

This College and Career Access Pathway Partnership Agreement (“CCAP Agreement”) is between the Allan Hancock Joint Community College District (“COLLEGE”) and Cuyama Joint Unified School District (“SCHOOL DISTRICT”). COLLEGE and SCHOOL DISTRICT will collectively be referred to as “PARTIES” or individually as “PARTY”.

RECITALS

WHEREAS, COLLEGE is a community college district whose mission includes providing educational programs and services that are responsive to the needs of the students and communities within the community college services area; and

WHEREAS, SCHOOL DISTRICT is a public school district located within the regional service area of the COLLEGE unless otherwise specified and agreed to as stated in AB 288, Sec. 2, Education Code section 76004, subdivision (e); and

WHEREAS, a high school (“HIGH SCHOOL”) “includes a community school, continuation high school, juvenile court school, or adult education program offering courses for high school diplomas or high school equivalency certificates” as stated in Education Code section 76004, subdivision (a)(2); and

WHEREAS, the PARTIES desire to enter into this CCAP Agreement for the purpose of offering or expanding dual enrollment opportunities, consistent with the provisions of the Education Code, for high school students “who may not already be college bound or who are underrepresented in higher education with the goal of developing seamless pathways from high school to community college for career technical education or preparation for transfer, improving high school graduation rates, and helping high school pupils achieve college and career readiness,” (Ed. Code, § 76004, subdivision (a)); and

WHEREAS, instruction will comply with the student selection standards, curriculum guidelines, recommendations and procedures promulgated by applicable law, the California Community College Chancellor’s Office and the COLLEGE; and

WHEREAS, the PARTIES desire to enter this CCAP, which sets forth their mutual rights and responsibilities and governs their relationship; and

WHEREAS, the PARTIES intend for COLLEGE to report full-time equivalent students (“FTES”) and obtain state apportionment for the subject courses given through this CCAP Agreement in

accordance with California Education Code, section 76004 and the appropriate portions of Title 5 of the California Code of Regulations; and

WHEREAS, participation in the CCAP Agreement is consistent with the core mission of California Community Colleges pursuant to Education Code section 66010.4, and that pupils participating in a CCAP partnership will not lead to enrollment displacement of otherwise eligible adults in the community college (Ed. Code, § 76004, subdivision (k)(2));

NOW, THEREFORE, PARTIES mutually agree as follows:

1. TERM OF AGREEMENT

1.1. **Effective Date and Duration.** The term of this CCAP Agreement shall be effective on **July 1, 2025**, and continue in effect until **June 30, 2026**, or until duly modified or terminated by the PARTIES in accordance with Section 1.2 of this CCAP Agreement.

1.2. Early Termination.

- a. This agreement may be terminated by either PARTY without cause or for any reason upon giving at least sixty (60) days prior written notice to the other PARTY. Any students currently enrolled in COLLEGE courses under this CCAP Agreement shall be allowed to complete those courses prior to the termination of this CCAP Agreement.
- b. This CCAP Agreement may be terminated by either PARTY with cause if another PARTY fails to comply with the insurance or indemnification requirements or otherwise commits a material breach. Termination will be effective no sooner than 15 calendar days after a written demand to cure is provided and the PARTY fails to cure. This remedy is in addition to any other remedy which may be provided for by law.

1.3. **The CCAP Agreement Appendix.** This CCAP Agreement outlines the terms of the Agreement.

- a. The CCAP Agreement Appendix shall specify CCAP Agreement Courses as well as additional details regarding, but not be limited to, the total number of high school students to be served and the total number of full-time equivalent students (“FTES”) projected to be claimed by the community college district for those students; the scope, nature, time, location, and listing of community college courses to be offered; and criteria to assess the ability of pupils to benefit from those courses:

Appendix A: Agreement with Instructor.

Appendix B: Identification of CCAP Pathways for Course-Specific College and Career Pathway Opportunities.

Appendix C: CCAP Agreement Courses Approved for 2025-2026.

Appendix D: Registration Timeline 2025-2026.

- b. The CCAP Agreement Appendix C shall be reviewed and approved annually by both PARTIES by a duly adopted written amendment to this Agreement.

1.4. **Points of contact and Educational Administrators** are as follows:

COLLEGE: Thomas Lamica, dean, academic affairs

SCHOOL DISTRICT:

HIGH SCHOOL SITE:

(Ed. Code, § 76004, subdivision (c)(2))

- 1.5. A copy of the COLLEGE and SCHOOL DISTRICT CCAP Agreement shall be filed with the office of the Chancellor of the California Community Colleges and with the California Department of Education before the start of the CCAP partnership. (Ed. Code, § 76004, subdivision (c)(3).)
- 1.6. COLLEGE and SCHOOL DISTRICT shall present this CCAP agreement at an open public meeting of their respective governing boards, allowing for public comments prior to consideration for approval or disapproval of this CCAP agreement. (Ed. Code, § 76004, subdivision (b)(2).)

2. DEFINITIONS

- 2.1. **CCAP Agreement Courses.** CCAP Agreement Courses offered as part of this CCAP Agreement shall be community college courses acceptable towards a career technical education credential or certificate, preparation for transfer, or appropriate to improve high school graduation rates or help high school pupils achieve college and career readiness. (Ed. Code § 76004, subdivision (a).) All community college courses offered at the SCHOOL DISTRICT have been approved in accordance with the policies and guidelines of COLLEGE and applicable law. Courses offered at the COLLEGE that are open to the public for enrollment fall outside of this CCAP agreement and are subject to all conditions and rules of the COLLEGE.
- 2.2. **Pupil or Student Fees.** Pupil or Student is defined as a resident or nonresident student attending HIGH SCHOOL in California. SCHOOL DISTRICT pupils enrolled in a course offered through this CCAP Agreement shall not be assessed any fee that is prohibited by Education Code section 49011 (Ed. Code § 76004, subdivision (f)), including a fee charged to a student or a student's parent or guardian as a condition for course registration or for textbooks, supplies, materials and equipment needed to participate in the course. Students who are enrolled in a combination of CCAP and regular credit college courses will be subject to all fees assessed for the regular credit college enrollment for the regular credit college courses.

3. STUDENT ELIGIBILITY, SELECTION AND ENROLLMENT, ADMISSION, REGISTRATION, MINIMUM SCHOOL DAY

- 3.1. **Student Eligibility.** Students who "may not already be college bound or who are underrepresented in higher education, with the goal of developing seamless pathways from

high school to community college for career technical education or preparation for transfer, improving high school graduation rates, or helping high school pupils to achieve college and career readiness" and "underachieving students, those from groups underrepresented in postsecondary education, those who are seeking advanced studies while in high school, and those seeking a career technical education credential or certificate" are eligible to participate in CCAP courses hosted at a SCHOOL DISTRICT site. (Education Code § 76004, subdivision (a); Assembly Bill 288 (2015) Section I, subdivision (d))

- 3.2. **Student Selection and Enrollment.** Enrollment shall be open to all eligible students as part of the CCAP Agreement who have been admitted to the COLLEGE and who meet all applicable prerequisites. Student selection criteria will be further specified in the CCAP Agreement Appendix C. Applicable prerequisite courses, training, or experience and standards required as preparation for courses offered through the CCAP Agreement will be determined by COLLEGE and shall be in compliance with applicable law and COLLEGE standards and policies.
- 3.3. **College Admission and Registration.** Procedures for students participating in the CCAP Agreement shall be governed by the COLLEGE and shall be in compliance with the admissions and registration guidelines outlined in applicable law and COLLEGE policy.
- 3.4. **Records of Student Attendance.** All records of student attendance and achievement shall be submitted to COLLEGE periodically using the COLLEGE student information system or upon demand and shall be maintained by COLLEGE.
- 3.5. **Priority Enrollment.** Students enrolling in a CCAP course will have priority enrollment by virtue of their status. High school students enrolling in non-CCAP college courses will not be eligible for priority registration.
- 3.6. **Physical Education Courses.** As part of a CCAP Agreement, a participating community college district shall not provide physical education course opportunities to high school students or any other course opportunities that do not assist in the attainment of the goals associated with career technical education or preparation for transfer, improving high school graduation rates, or helping high school students achieve career and college readiness. (Ed. Code § 76004, subdivision (d)).
- 3.7. **Maximum Units.** Students participating under a CCAP Agreement may enroll in up to a maximum of 15 units per term, without exception, if all the following conditions specified in Assembly Bill 288, Sec. 2 (p)(1)(2)(3) are satisfied:
 - a. The units constitute no more than four community college courses per term.
 - b. The units are part of an academic program that is part of a CCAP partnership agreement established pursuant to this article.
 - c. The units are part of an academic program that is designed to award students both a high school diploma and an associate degree or a certificate or credential.
- 3.8. **Minimum School Day.** The SCHOOL DISTRICT shall certify that it shall teach SCHOOL DISTRICT students participating as part of a CCAP Agreement no less than the number of instructional minutes required to complete a minimum school day pursuant to Education Code sections 46141 and 46142.
- 3.9. **Enrollment Restriction.** COLLEGE reserves the right to block students from enrolling in any courses for students who incur an unpaid debt for a non-CCAP class at the college. COLLEGE agrees to remove the enrollment block when debt is paid in full.

4. COLLEGE APPLICATION PROCEDURE

- 4.1. The COLLEGE will be responsible for processing student applications.
- 4.2. The COLLEGE will provide the necessary admission and registration forms and procedures, and both COLLEGE and SCHOOL DISTRICT will jointly ensure that each applicant accepted has met all the enrollment requirements.
- 4.3. The SCHOOL DISTRICT agrees to assist COLLEGE in the admission and registration of SCHOOL DISTRICT students as may be necessary and requested by COLLEGE.

5. PARTICIPATING STUDENTS

- 5.1. The total cost of books and instructional materials for SCHOOL DISTRICT students who enroll in a COLLEGE course offered as part of this CCAP Agreement will be borne by SCHOOL DISTRICT.
- 5.2. Both COLLEGE and SCHOOL DISTRICT will ensure that ancillary and support services are accessible to students (e.g., Tutoring.)
- 5.3. A student taking courses under this CCAP Agreement with an Individual Education Plan or 504 Plan with the SCHOOL DISTRICT may request accommodation for his or her disability to participate in the educational programs and activities required by the COURSE and COLLEGE. Accommodation required by state law or SCHOOL DISTRICT policy will be provided through SCHOOL DISTRICT in consultation with the COLLEGE Learning Assistance Program (LAP) Office. Students requesting services by the LAP office will need to follow the standard process for requesting accommodations.

6. CCAP AGREEMENT COURSES

- 6.1. The COLLEGE may limit enrollment in a community college course solely to eligible high school students if the course is offered at a high school campus during the regular school day and the community college course is offered pursuant to this CCAP Agreement.
- 6.2. The COLLEGE is responsible for all courses and educational programs offered as part of CCAP Agreement .
- 6.3. The scope, nature, time, location, and listing of courses offered by a COLLEGE shall be determined by COLLEGE in consultation with the SCHOOL DISTRICT and with the approval of the COLLEGE and will be recorded in the Appendix C to this CCAP Agreement.
- 6.4. Courses offered as part of a CCAP Agreement shall be jointly selected and approved by COLLEGE and SCHOOL DISTRICT.
- 6.5. Courses offered as part of this CCAP Agreement shall have a minimum enrollment of fifteen (15) students.
- 6.6. The SCHOOL DISTRICT confirms that each approved CCAP course is held for no less than 50 minutes each class day in full compliance with the course outcomes determined by the COLLEGE.
- 6.7. Degree and certificate programs that are included in the CCAP agreement must have been approved by the California Community College Chancellor's Office and courses offered at the SCHOOL DISTRICT shall adhere to the official course outline of record and the student

- learning outcomes established by the associated academic department within the COLLEGE, approved by the COLLEGE Academic Policy & Planning (AP&P) Committee and submitted to the Chancellor's Office. Course outlines will be provided to the SCHOOL DISTRICT.
- 6.8. Courses must meet the number of hours sufficient to meet the stated performance objectives as outlined in the course outlines provided to the SCHOOL DISTRICT on a semester basis.
 - 6.9. Courses offered at the SCHOOL DISTRICT as part of this CCAP Agreement shall be of the same quality and rigor as those offered on the COLLEGE campus and shall be in compliance with COLLEGE academic standards.
 - 6.10. Courses offered as part of this CCAP Agreement will comply with all applicable regulations, policies, procedures, prerequisites, and standards applicable to the COLLEGE as well as any corresponding policies, practices, and requirements of the SCHOOL DISTRICT. In the event of a conflict between the COLLEGE course related regulations, policies, procedures, prerequisites and standards and SCHOOL DISTRICT policies, practices and requirements, the COLLEGE regulations, policies, procedures, prerequisites, and standards, shall prevail.
 - 6.11. A student's withdrawal prior to completion of a course offered as part of this CCAP Agreement shall be in accordance with COLLEGE guidelines, policies, pertinent statutes and regulations.
 - 6.12. Supervision and evaluation of students enrolled in courses offered as part of this CCAP Agreement shall be in accordance with COLLEGE guidelines, policies, pertinent statutes and regulations.
 - 6.13. COLLEGE has the sole right to control and direct the instructional activities for all CCAP Agreement courses and all instructors, including those who are SCHOOL DISTRICT employees.
 - 6.14. This CCAP Agreement certifies that any remedial course taught by community college faculty at a partnering high school campus shall be offered only to high school students who do not meet their grade level standard in math, English, or both on an interim assessment in grade 10 or 11, as determined by the partnering SCHOOL DISTRICT, and shall involve collaborative effort between the SCHOOL DISTRICT and the COLLEGE faculty to deliver an innovative remediation course as an intervention in the student's junior or senior year to ensure the student is prepared for college-level work upon graduation.
 - 6.15. CCAP Agreement Courses outlined in Appendix C shall be updated annually and approved before the start of each academic year.

7. INSTRUCTORS

- 7.1. All instructors teaching COLLEGE courses offered as part of this CCAP Agreement must meet the minimum qualifications for instruction in a California community college as set forth in Title 5 California Code of Regulations, Sections 53410 and 58060 or as amended.
- 7.2. The CCAP Agreement Appendix C shall specify which participating SCHOOL DISTRICT or COLLEGE will be the employer of record for purposes of assignment monitoring and reporting to the county office of education.
- 7.3. This CCAP Agreement specifies that the SCHOOL DISTRICT will assume reporting

- responsibilities pursuant to applicable federal teacher quality mandates.
- 7.4. Instructors who teach COLLEGE courses offered as part of this CCAP Agreement must provide the supervision and control reasonably necessary for the protection of the health and safety of students and may not have any other assigned duty during the instructional activity.
 - 7.5. Instructors who teach COLLEGE courses shall comply with the fingerprinting requirements set forth in Education Code section 45125 or as amended and the tuberculosis testing and risk assessment requirements of California Health and Safety Code section 121525 or as amended. In addition to any other prohibition or provision, no person who has been convicted of a violent or serious felony shall be eligible to teach any courses offered as part of this CCAP Agreement or otherwise provide services on a SCHOOL DISTRICT site. SCHOOL DISTRICT shall immediately notify COLLEGE if an instructor is charged with an offense prohibited by Education Code sections 44010 or 44011.
 - 7.6. Prior to teaching, faculty provided by the SCHOOL DISTRICT shall participate in required discipline-specific training and orientation from COLLEGE regarding, but not limited to, course curriculum, assessment criteria, pedagogy, course philosophy, testing and grading procedures record keeping, and other instructional responsibilities. Such training shall be approved and provided by the COLLEGE.
 - 7.7. Prior to teaching, instructors provided by the COLLEGE may receive training and orientation from SCHOOL DISTRICT regarding, but not limited to, SCHOOL DISTRICT policies, practices, and requirements. Such training may be approved and provided by the SCHOOL DISTRICT.
 - 7.8. Faculty provided by the SCHOOL DISTRICT are eligible to participate in professional development activities sponsored by the COLLEGE as required by the terms and condition of the contract and shall be encouraged to participate in ongoing collegial interaction to include, but not limited to, addressing course content, course delivery, assessment, evaluation, and/or research and development in the field.
 - 7.9. The COLLEGE shall evaluate faculty performance for the college courses using the adopted evaluation of process and standards for faculty of the COLLEGE, subject to the approval of COLLEGE.
 - 7.10. The COLLEGE and SCHOOL DISTRICT will work collaboratively to identify instructors from SCHOOL DISTRICT who may meet minimum qualification requirements or local equivalency standards to teach a COLLEGE course and encourage them to apply for consideration. Instructors will be required to go through the COLLEGE screening process for possible selection and assignment to the course.
 - 7.11. The SCHOOL DISTRICT teachers approved to teach COLLEGE courses remain employees of the SCHOOL DISTRICT, subject to the authority of the SCHOOL DISTRICT, but will also be subject to the authority of COLLEGE specifically with regard to their duties as COLLEGE instructors, pursuant to the terms of Appendix A.
 - 7.12. The COLLEGE shall determine the number of instructors, the ratio of instructors to students, and the subject areas of instruction.
 - 7.13. Faculty provided by the SCHOOL DISTRICT who do not comply with the policies, regulations, standards, and expectations of the COLLEGE shall be ineligible to teach college courses under this CCAP Agreement.
 - 7.14. SCHOOL DISTRICT teachers approved to teach CCAP Courses under this CCAP

Agreement must submit grades to both the COLLEGE and SCHOOL DISTRICT using the COLLEGE student information system by the established timeline (Appendix D).

- 7.15. SCHOOL DISTRICT teachers approved by the COLLEGE shall sign an Agreement with the Instructor (Appendix A) prior to the start of each academic year.
- 7.16. SCHOOL DISTRICT teachers approved by the COLLEGE shall provide support to high school students taking COLLEGE courses under CCAP agreement with COLLEGE admission and registration procedures.

8. ASSESSMENT OF LEARNING AND CONDUCT

- 8.1. Students enrolled in COLLEGE courses offered as part of this CCAP Agreement at the SCHOOL DISTRICT shall be held to the same standards of achievement as students in courses taught on the COLLEGE campus.
- 8.2. Students enrolled in COLLEGE courses offered as part of this CCAP Agreement at the SCHOOL DISTRICT shall be held to the same grading standards as those expected of students in courses taught on the COLLEGE campus.
- 8.3. Students enrolled in COLLEGE courses offered as part of this CCAP Agreement at the SCHOOL DISTRICT shall be assessed using the same methods (e.g., papers, portfolios, quizzes, labs, etc.) as students in courses taught on the COLLEGE campus.
- 8.4. Students enrolled in COLLEGE courses offered as part of this CCAP Agreement at the SCHOOL DISTRICT shall be held to the same behavioral standards as those expected of students in courses taught on the COLLEGE campus.

9. LIAISON AND COORDINATION OF RESPONSIBILITIES

- 9.1. The COLLEGE shall appoint an educational administrator who will serve as point of contact to facilitate coordination and cooperation between COLLEGE, SCHOOL DISTRICT, and HIGH SCHOOL in conformity with COLLEGE policies and standards. (Ed. Code, § 76004, subd. (c)(2).) Among other things, the COMMUNITY COLLEGE DISTRICT Educational Administrator and the SCHOOL DISTRICT Educational Administrator described in Section 9.2, shall collaborate to determine the process for timely receiving, investigating, and remediating complaints of sexual misconduct or other conduct covered by Title IX of the Education Amendments of 1972 alleged to have occurred in or related to the CCAP program.
- 9.2. The SCHOOL DISTRICT shall appoint an educational administrator who will serve as point of contact to facilitate coordination and cooperation between SCHOOL DISTRICT, COLLEGE, HIGH SCHOOL in conformity with SCHOOL DISTRICT policies and standards.
- 9.3. This CCAP Agreement requires an annual report to the office of the Chancellor of the California Community Colleges by COLLEGE and SCHOOL DISTRICT. COLLEGE shall complete and file the Apportionment Attendance Report (CCFS-320); SCHOOL DISTRICT agrees to provide the following information, when requested by COLLEGE, in accordance with AB 288 Section 2, Education Code Section 76004:
 - a. The total number of high school students by school site enrolled in each partnership, aggregated by gender and ethnicity, and reported in compliance with all applicable state and federal privacy laws.

- b. The total number of community college courses by course category and type and by school site enrolled in by CCAP partnership participants.
- c. The total number and percentage of successful course completions, by course category and type and by school site, of CCAP partnership participants.
- d. The total number of full-time equivalent students generated by CCAP partnership community college district participants.

10. DISPUTES

10.1. COLLEGE and SCHOOL DISTRICT recognize that, from time to time, disputes may arise between COLLEGE employees or students and SCHOOL DISTRICT employees or students. When such disputes arise, COLLEGE and SCHOOL DISTRICT shall collaborate and use their best efforts to resolve them informally. Where informal resolution is not successful or the PARTIES must address a formal inter-agency complaint, the following process will be utilized to resolve the matter.

- a. The PARTY receiving the complaint will timely notify the other, and promptly provide the other PARTY with any written complaint received.
- b. The Educational Administrators will review the complaint to determine, based on the nature of the complaint, whether any statutory or regulatory timelines or other procedural requirements apply, including but not limited to:

10.1.b.1. Whether COLLEGE is required to investigate the complaint to the State Chancellor pursuant to Title 5 of the California Code of Regulations.

10.1.b.2. Whether, based on the nature of the complaint, the complainant is entitled to any rights or protections with regard to how the complaint is handled, pursuant to Title 5 or applicable state or federal laws, including but not limited to Title IX of the Education Amendments of 1972.

10.1.b.3. If either Educational Administrator finds such rights to exist, he or she shall notify the other Educational Administrator, and COLLEGE and SCHOOL DISTRICT shall cooperate as needed in carrying out these requirements. It is understood that such requirements may include but are not limited to conducting a formal investigation within regulatory timelines or the implementation of interim safety measures for the complainant.

- c. Within a reasonable time, either PARTY receiving the complaint, the PARTIES will discuss the nature and severity of the allegations and come to a mutual agreement regarding the need for and scope of any investigation required. If it is agreed that a formal investigation is required, the PARTIES will mutually agree upon an investigator, who may be an outside investigator, or qualified employee of COLLEGE or SCHOOL DISTRICT. If the PARTIES agree to have the matter investigated internally by either a COLLEGE or SCHOOL DISTRICT employee, the other PARTY may designate an employee to attend all witness interviews. Where it is determined that an outside investigator will be used, the cost will be divided between the PARTIES.
- d. If, despite the good faith effort of the PARTIES, they are unable to agree on a process for investigating the complaint, the PARTY whose employee/student is the subject of the complaint will determine the process.

- e. The COLLEGE and SCHOOL DISTRICT will cooperate in any investigation initiated and make its employees available to the investigator.
- f. Interviews of COLLEGE and SCHOOL DISTRICT employees shall comply with any rights and protections afforded to them under an applicable collective bargaining agreement or state or federal law, including but not limited to the right to have a representative present during an interview that could lead to discipline.
- g. The investigator will prepare a report that will be provided to both PARTIES setting forth findings as to the allegations and the basis for the findings.
- h. The COLLEGE and SCHOOL DISTRICT shall share any and all materials from the investigation, unless sharing would cause a PARTY to violate confidentiality or privacy laws.
- i. The COLLEGE and SCHOOL DISTRICT have sole discretion in determining any disciplinary measures to be imposed against their respective employees or students.
- j. Regardless of any disciplinary measures taken by the COLLEGE or SCHOOL DISTRICT against its respective employees or students, the other PARTY retains the right to have the subject of a sustained complaint removed from participating in or providing services for the program that is the subject of this CCAP Agreement.

11. APPORTIONMENT

- 11.1. COLLEGE shall include the students enrolled in a CCAP Agreement course in its report of full-time equivalent students (FTES) for purposes of receiving state apportionments when the course(s) complies with current requirements for dual enrollment under applicable California law.
- 11.2. For purposes of allowances and apportionments from Section B of the State School Fund, a community college district conducting a closed course on a high school campus shall be credited with those units of full-time equivalent students attributable to the attendance of eligible high school pupils.
- 11.3. The COLLEGE shall not receive a state allowance or apportionment for an instructional activity for which the SCHOOL DISTRICT has been, or shall be, paid an allowance or apportionment. (Ed. Code § 76004, subdivision (o)(2)).
- 11.4. The attendance of a SCHOOL DISTRICT pupil at the COLLEGE as a special part-time or full-time student pursuant to this section is authorized attendance for which the COLLEGE shall be credited or reimbursed pursuant to Section 48802 or 76002, provided that no school district has received reimbursement for the same instructional activity.

12. CERTIFICATIONS

- 12.1. The SCHOOL DISTRICT certifies that:
 - a. The direct education costs of the courses offered as part of this CCAP Agreement are not fully funded through other sources.
 - b. It agrees and acknowledges that the COLLEGE will claim apportionment for the SCHOOL DISTRICT students enrolled in community college course(s) under this CCAP Agreement.

- c. Any COLLEGE instructor teaching a course at the SCHOOL DISTRICT has not displaced or resulted in the termination of an existing high school teacher teaching the same course on that high school campus.

12.2. The COLLEGE certifies that:

- a. A community college course offered for college credit at the participating SCHOOL DISTRICT does not reduce access to the same course offered at the partnering COLLEGE.
- b. The COLLEGE has not received full compensation for the direct education costs for the conduct of the courses offered as part of this CCAP Agreement from other sources.
- c. The Agreement is consistent with the core mission of the COLLEGE pursuant to Section 66010.4 and students participating in this CCAP Agreement will not lead to displacement of otherwise eligible adults at the COLLEGE.
- d. A qualified SCHOOL DISTRICT instructor teaching a course offered for college credit at a high school campus has not displaced or resulted in the termination of an existing COLLEGE faculty member teaching the same course at the partnering community college campus.

12.3. The PARTIES certify that:

- a. Any COLLEGE instructor teaching a course on a SCHOOL DISTRICT campus has not been convicted of any sex offense as defined in Education Code section 44010 or as amended, or any controlled substance offense as defined in Education Code section 44011 or as amended.
- b. The SCHOOL DISTRICT and COLLEGE comply with local collective bargaining agreements and all state and federal reporting requirements regarding the qualifications of the teacher or faculty member teaching a CCAP Agreement course offered for high school credit. (AB288 Sec. 2 (I).)

13. PROGRAM IMPROVEMENT

- 13.1. The COLLEGE and the SCHOOL DISTRICT may annually conduct surveys of participating SCHOOL DISTRICT pupils, instructors, principals, and school counselors for the purpose of informing practice, adjusting, and improving the quality of courses offered as part of this CCAP Agreement.

14. RECORDS

- 14.1. Permanent records of student attendance, grades and achievement will be maintained by both the SCHOOL DISTRICT and COLLEGE for SCHOOL DISTRICT students who enroll in course(s) offered as part of this CCAP Agreement. Permanent records of student enrollment, grades, and achievement for COLLEGE students shall be maintained by COLLEGE.
- 14.2. Each PARTY shall maintain records pertaining to this CCAP Agreement as may be required by federal and state law. Each PARTY may review and obtain a copy of the other

PARTY'S pertinent records subject to federal and state privacy statutes.

- 14.3. SCHOOL DISTRICT instructors will submit grades to the COLLEGE when due according to the COLLEGE schedule per section 7.14. The SCHOOL DISTRICT will include all criteria identified by the COLLEGE for grading purposes.
- 14.4. COLLEGE may provide the SCHOOL DISTRICT with a report on participating students' final grades after each term.

15. CCAP AGREEMENT DATA MATCH AND REPORTING

- 15.1. COLLEGE and SCHOOL DISTRICT shall ensure operational protocols consistent with the collection of participating student data and the timely submission of the data.
- 15.2. COLLEGE shall report all program and participating student data to the office of the Chancellor of the California Community Colleges.

16. DATA SHARING

- 16.1. COLLEGE and SCHOOL DISTRICT may share confidential student data for the purposes of evaluating the educational services provided under this CCAP agreement and for evaluating student performance pursuant to participating in CCAP courses. Any data shared will be for research and analytical purposes aimed at understanding student performance and improving applicable federal and state laws concerning access to and confidentiality of student record information as described in Section 17 of this agreement.

17. PRIVACY OF STUDENT RECORDS

- 17.1. COLLEGE and SCHOOL DISTRICT understand and agree that education records of students enrolled in a CCAP course and personally identifiable information contained in those educational records are subject to the Family Educational Rights and Privacy Act (FERPA) 20 U.S.C. § 1232g; 34 C.F.R. Part 99, including the disclosure provisions of § 99.30 and state law as outlined in Education Code section 49064 and section 49076). COLLEGE and SCHOOL DISTRICT agree to hold all student education records generated pursuant to this CCAP Agreement in strict confidence and further agree not to disclose such records except as authorized by applicable law or regulation for COLLEGE records or by the parent or guardian's prior written consent for HIGH SCHOOL records. (34 C.F.R. § 99.33 (a), (b); 34 C.F.R. § 99.34(b) and Education Code §§ 49064 and 49076.)
- 17.2. **Limitation on Use.** COLLEGE and SCHOOL DISTRICT shall use each student education record that they may receive pursuant to this CCAP Agreement solely for purposes consistent with their authority to access that information pursuant to Federal and State law, as may be as applicable. (34 C.F.R. § 99.31, 34 C.F.R. § 99.34, and Education Code § 49076.)
- 17.3. **Recordkeeping Requirements.** COLLEGE and SCHOOL DISTRICT shall comply with the requirements governing maintenance of records of each request for access to and each disclosure of student education records set forth under Title 34, Code of Federal Regulations § 99.32 and under Education Code § 49064 as applicable.
- 17.4. **Acknowledgement of Receipt of Notice of FERPA Regulations.** By signature of its authorized representative or agent on this Agreement, COLLEGE and SCHOOL DISTRICT hereby acknowledges that it has been provided with the notice required under

34 C.F.R. § 99.33(d) that it is strictly prohibited from re-disclosing student education records to any other person or entity except as authorized by applicable law or regulation. Parent or guardian requests for information will need to be addressed directly by the HIGH SCHOOL or SCHOOL DISTRICT personnel.

18. REIMBURSEMENT

- 18.1. The SCHOOL DISTRICT shall invoice the COLLEGE no later than 30 (thirty) days after the start of each term for the instructional services provided through this CCAP agreement as follows:
- a. For courses taught by COLLEGE-approved SCHOOL DISTRICT teachers and COLLEGE instructors on HIGH SCHOOL campuses during regular high school hours rendered at the rate of \$1,000.00 per course unit delivered to CCAP students.

Example: 3 CCAP courses @ 3 units each = 9 units x \$1,000.00 = \$9,000.00

- 18.2. The COLLEGE shall make payment to the SCHOOL DISTRICT within 30 days of receiving the invoice for instructional services rendered.
- 18.3. The COLLEGE is required to report to the state the percentage of funds paid to an agency to the SCHOOL DISTRICT that will provide direct instruction on behalf of the college as part of the CCAP partnership agreement. The SCHOOL DISTRICT will use 100% of all funds received from Allan Hancock College in fulfillment of this agreement to pay for direct instructional costs. (Ed. Code § 84632).

19. FACILITIES

- 19.1. The SCHOOL DISTRICT will provide adequate classroom space at its facilities or other mutually agreed upon locations to conduct the instruction and do so without charge to COLLEGE or students. SCHOOL DISTRICT agrees to clean, maintain, and safeguard SCHOOL DISTRICT's premises. SCHOOL DISTRICT warrants that its facilities are safe and compliant with all applicable buildings, fire, and safety codes.
- 19.2. The SCHOOL DISTRICT will furnish, at its own expense, all course materials, specialized equipment, books and other necessary equipment for all SCHOOL DISTRICT students. The parties understand that such equipment and materials are the SCHOOL DISTRICT's sole property.
- 19.3. The SCHOOL DISTRICT facilities may be used by COLLEGE for COLLEGE course offerings before or after regular high school schedule at no additional cost. Prior approval by the SCHOOL DISTRICT is required. COLLEGE courses offered before or after the regular high school schedule will be open to the public.

20. INDEMNIFICATION

- 20.1. The SCHOOL DISTRICT agrees to and shall indemnify, save and hold harmless the COLLEGE, and its governing board, officers, employees, administrators, independent

contractors, subcontractors, agents and other representatives from any and all claims, demands, liabilities, costs, expenses, damages, causes of action, losses, and judgments, arising out of SCHOOL DISTRICT's performance of this CCAP Agreement. The obligation to indemnify shall extend to all claims and losses that arise out of SCHOOL DISTRICT's or its trustees', officers', agents', or employees' negligence, wrongful acts or omissions, or willful misconduct related to this CCAP Agreement or performance of this CCAP Agreement. The provisions of this section shall survive the termination or expiration of this CCAP Agreement.

20.2. The COLLEGE agrees to and shall indemnify, save and hold harmless the SCHOOL DISTRICT and its governing board, officers, employees, administrators, independent contractors, subcontractors, agents and other representatives from any and all claims, demands, liabilities, costs, expenses, damages, causes of action, losses, and judgments, arising out of COLLEGE'S performance of this CCAP Agreement. The obligation to indemnify shall extend to all claims and losses that arise out of COLLEGE'S or its trustees', officers', agents', or employees' negligence, wrongful acts or omissions, or willful misconduct related to this CCAP Agreement or performance of this CCAP Agreement. The provisions of this section shall survive the termination or expiration of this CCAP Agreement.

21. INSURANCE

21.1. The SCHOOL DISTRICT, in order to protect the COLLEGE, its agents, employees and officers against claims and liability for death, injury, loss and damage arising out of or in any manner connected with the performance and operation of the terms of this CCAP Agreement, shall secure and maintain in force during the entire term of this CCAP Agreement, insurance coverage or an approved program of self-insurance in the amount of not less than ONE MILLION DOLLARS (\$1,000,000) per incident and TWO MILLION DOLLARS (\$2,000,000) general aggregate for personal injury, bodily injury, death, and property and other damage, with an admitted California insurer duly licensed to engage in the business of insurance in the State of California, or public entity risk management Joint Powers Authority, authorized to provide public liability and property damage insurance in the state of California. Said policy of insurance, insurance coverage through a public entity risk management JPA, or program of self-insurance shall expressly name the COLLEGE, its agents, employees and officers as an additional insured for the purposes of this CCAP Agreement. A certificate of insurance including such endorsement shall be furnished to the COLLEGE.

21.2. The COLLEGE, in order to protect the SCHOOL DISTRICT, its agents, employees and officers against claims and liability for death, injury, loss and damage arising out of or in any manner connected with the performance and operation of the terms of this CCAP Agreement, shall secure and maintain in force during the entire term of this CCAP Agreement, insurance coverage or an approved program of self-insurance in the amount of not less than ONE MILLION DOLLARS (\$1,000,000) per incident and TWO MILLION DOLLARS (\$2,000,000) general aggregate for personal injury, bodily injury, death, and property and other damage, with an admitted California insurer duly licensed to engage in the business of insurance in the State of California, or public entity risk management Joint Powers Authority, authorized to provide public liability and property damage insurance in the State

of California. Said policy of insurance, insurance coverage through a public entity risk management JPA or program of self-insurance shall expressly name the SCHOOL DISTRICT, its agents, employees and officers as an additional insured for the purposes of this CCAP Agreement. A certificate of insurance including such endorsement shall be furnished to the SCHOOL DISTRICT.

- 21.3. For the purpose of Workers' Compensation, SCHOOL DISTRICT shall be the "primary employer" for all its employees who perform services as instructors and support staff. SCHOOL DISTRICT shall be solely responsible for processing, investigating, defending, and paying all workers' compensation claims by their respective SCHOOL DISTRICT employees made in connection with performing services and receiving instruction under this CCAP Agreement. SCHOOL DISTRICT agrees to hold harmless, indemnify, and defend COLLEGE, its directors, officers, agents, and employees from any liability resulting from its failure to process, investigate, defend, or pay any workers' compensation claims by SCHOOL DISTRICT employees connected with providing services under this CCAP Agreement.

22. NON-DISCRIMINATION

- 22.1. Neither the SCHOOL DISTRICT nor the COLLEGE shall discriminate on the basis of race or ethnicity, gender, nationality, physical or mental disability, sexual orientation, religion, or any other protected class under California State or federal law.

23. NOTICES

- 23.1. Any and all notices required to be given hereunder shall be deemed given when personally delivered or deposited in the U.S. Mail, postage to be prepaid, to the following addresses:

Allan Hancock College Joint Community College District
800 S. College Drive
Santa Maria, CA 93460
Attn: Dennis Curran

Cuyama Joint Unified School District
2300 Highway 166, New Cuyama, CA 93254
Attn:

24. MODIFICATION AND AMENDMENT

- 24.1. Appendix A through D to this CCAP Agreement is incorporated by this reference into this CCAP Agreement.
- 24.2. This CCAP Agreement and Appendix A through D to this CCAP Agreement set forth the entire agreement between the PARTIES relating to the subject matter of this CCAP Agreement. This CCAP Agreement and Appendix A through D to this CCAP Agreement supersede any prior agreements, promises, negotiations, or representations, express or implied, oral or written, not included in this CCAP Agreement and Appendix A through D

to this CCAP Agreement.

24.3. This Agreement may be amended only with the mutual consent of the Parties. All amendments must be in writing and must be approved by the Parties' respective governing Boards.

25. GOVERNING LAWS

25.1. This CCAP Agreement will be governed by and construed in accordance with California law, and the venue of any action or proceeding in connection with this CCAP Agreement shall be Santa Barbara County, California.

26. COMMUNITY COLLEGE DISTRICT BOUNDARIES

26.1. For locations outside the geographical boundaries of Allan Hancock College Joint Community College District, the COLLEGE will comply with the requirements of Title 5 of the California Code of Regulations, Sections 55300 et seq. or as amended, concerning approval by adjoining high school or community college districts and use of non-district facilities.

27. SEVERABILITY

27.1. This CCAP Agreement shall be considered severable, such that if any provision or part of the CCAP Agreement is ever held invalid under any law or ruling, that provision or part of the CCAP Agreement shall remain in force and effect to the extent allowed by law, and all other provisions or parts shall remain in full force and effect.

28. COUNTERPARTS

28.1. This CCAP Agreement may be executed by the PARTIES in separate counterparts, each of which when so executed and delivered shall be an original, but all such counterparts shall together constitute one and the same instrument.

IN WITNESS WHEREOF, the PARTIES hereto have caused this CCAP Agreement to be executed on the dates set forth below, to be effective as of the Effective Date.

ALLAN HANCOCK JOINT COMMUNITY COLLEGE DISTRICT

By: _____
Associate Superintendent/Vice President of Finance and Administration

Date: _____

CUYAMA JOINT UNIFIED SCHOOL DISTRICT

By: _____
Superintendent/Principal

Date: _____

ALLAN HANCOCK JOINT COMMUNITY COLLEGE DISTRICT BOARD MEETINGS

Information Board Meeting Date:

Public Comment
and Approval Board Meeting Date:

CUYAMA JOINT UNIFIED SCHOOL DISTRICT BOARD MEETINGS

Information Board Meeting Date:

Public Comment
and Approval Board Meeting Date:

**COLLEGE AND CAREER ACCESS PATHWAYS (CCAP)
PARTNERSHIP AGREEMENT
BETWEEN
THE ALLAN HANCOCK JOINT COMMUNITY COLLEGE DISTRICT
AND
GATEWAY COMMUNITY CHARTERS**

This College and Career Access Pathway Partnership Agreement (“CCAP Agreement”) is between the Allan Hancock Joint Community College District (“COLLEGE”) and Gateway Community Charters (“SCHOOL DISTRICT”). COLLEGE and SCHOOL DISTRICT will collectively be referred to as “PARTIES” or individually as “PARTY”.

RECITALS

WHEREAS, COLLEGE is a community college district whose mission includes providing educational programs and services that are responsive to the needs of the students and communities within the community college services area; and

WHEREAS, SCHOOL DISTRICT is a public school district located within the regional service area of the COLLEGE unless otherwise specified and agreed to as stated in AB 288, Sec. 2, Education Code section 76004, subdivision (e); and

WHEREAS, a high school (“HIGH SCHOOL”) “includes a community school, continuation high school, juvenile court school, or adult education program offering courses for high school diplomas or high school equivalency certificates” as stated in Education Code section 76004, subdivision (a)(2); and

WHEREAS, the PARTIES desire to enter into this CCAP Agreement for the purpose of offering or expanding dual enrollment opportunities, consistent with the provisions of the Education Code, for high school students “who may not already be college bound or who are underrepresented in higher education with the goal of developing seamless pathways from high school to community college for career technical education or preparation for transfer, improving high school graduation rates, and helping high school pupils achieve college and career readiness,” (Ed. Code, § 76004, subdivision (a)); and

WHEREAS, instruction will comply with the student selection standards, curriculum guidelines, recommendations and procedures promulgated by applicable law, the California Community College Chancellor’s Office and the COLLEGE; and

WHEREAS, the PARTIES desire to enter this CCAP, which sets forth their mutual rights and responsibilities and governs their relationship; and

WHEREAS, the PARTIES intend for COLLEGE to report full-time equivalent students (“FTES”) and obtain state apportionment for the subject courses given through this CCAP Agreement in

accordance with California Education Code, section 76004 and the appropriate portions of Title 5 of the California Code of Regulations; and

WHEREAS, participation in the CCAP Agreement is consistent with the core mission of California Community Colleges pursuant to Education Code section 66010.4, and that pupils participating in a CCAP partnership will not lead to enrollment displacement of otherwise eligible adults in the community college (Ed. Code, § 76004, subdivision (k)(2));

NOW, THEREFORE, PARTIES mutually agree as follows:

1. TERM OF AGREEMENT

1.1. **Effective Date and Duration.** The term of this CCAP Agreement shall be effective on **July 1, 2025**, and continue in effect until **June 30, 2026**, or until duly modified or terminated by the PARTIES in accordance with Section 1.2 of this CCAP Agreement.

1.2. Early Termination.

- a. This agreement may be terminated by either PARTY without cause or for any reason upon giving at least sixty (60) days prior written notice to the other PARTY. Any students currently enrolled in COLLEGE courses under this CCAP Agreement shall be allowed to complete those courses prior to the termination of this CCAP Agreement.
- b. This CCAP Agreement may be terminated by either PARTY with cause if another PARTY fails to comply with the insurance or indemnification requirements or otherwise commits a material breach. Termination will be effective no sooner than 15 calendar days after a written demand to cure is provided and the PARTY fails to cure. This remedy is in addition to any other remedy which may be provided for by law.

1.3. **The CCAP Agreement Appendix.** This CCAP Agreement outlines the terms of the Agreement.

- a. The CCAP Agreement Appendix shall specify CCAP Agreement Courses as well as additional details regarding, but not be limited to, the total number of high school students to be served and the total number of full-time equivalent students (“FTES”) projected to be claimed by the community college district for those students; the scope, nature, time, location, and listing of community college courses to be offered; and criteria to assess the ability of pupils to benefit from those courses:

Appendix A: Agreement with Instructor.

Appendix B: Identification of CCAP Pathways for Course-Specific College and Career Pathway Opportunities.

Appendix C: CCAP Agreement Courses Approved for 2025-2026.

Appendix D: Registration Timeline 2025-2026.

- b. The CCAP Agreement Appendix C shall be reviewed and approved annually by both PARTIES by a duly adopted written amendment to this Agreement.

1.4. **Points of contact and Educational Administrators** are as follows:

COLLEGE:	Thomas Lamica, dean, academic affairs
SCHOOL DISTRICT:	Ashley Madden, director of College & Career Readiness
HIGH SCHOOL SITE:	Summer Ash, SAVA Jon Campbell, Community Collaborative Charter

(Ed. Code, § 76004, subdivision (c)(2))

1.5. A copy of the COLLEGE and SCHOOL DISTRICT CCAP Agreement shall be filed with the office of the Chancellor of the California Community Colleges and with the California Department of Education before the start of the CCAP partnership. (Ed. Code, § 76004, subdivision (c)(3).)

1.6. COLLEGE and SCHOOL DISTRICT shall present this CCAP agreement at an open public meeting of their respective governing boards, allowing for public comments prior to consideration for approval or disapproval of this CCAP agreement. (Ed. Code, § 76004, subdivision (b)(2).)

2. DEFINITIONS

2.1. **CCAP Agreement Courses.** CCAP Agreement Courses offered as part of this CCAP Agreement shall be community college courses acceptable towards a career technical education credential or certificate, preparation for transfer, or appropriate to improve high school graduation rates or help high school pupils achieve college and career readiness. (Ed. Code § 76004, subdivision (a).) All community college courses offered at the SCHOOL DISTRICT have been approved in accordance with the policies and guidelines of COLLEGE and applicable law. Courses offered at the COLLEGE that are open to the public for enrollment fall outside of this CCAP agreement and are subject to all conditions and rules of the COLLEGE.

2.2. **Pupil or Student Fees.** Pupil or Student is defined as a resident or nonresident student attending HIGH SCHOOL in California. SCHOOL DISTRICT pupils enrolled in a course offered through this CCAP Agreement shall not be assessed any fee that is prohibited by Education Code section 49011 (Ed. Code § 76004, subdivision (f)), including a fee charged to a student or a student's parent or guardian as a condition for course registration or for textbooks, supplies, materials and equipment needed to participate in the course. Students who are enrolled in a combination of CCAP and regular credit college courses will be subject to all fees assessed for the regular credit college enrollment for the regular credit college courses.

3. STUDENT ELIGIBILITY, SELECTION AND ENROLLMENT, ADMISSION, REGISTRATION, MINIMUM SCHOOL DAY

3.1. **Student Eligibility.** Students who "may not already be college bound or who are

underrepresented in higher education, with the goal of developing seamless pathways from high school to community college for career technical education or preparation for transfer, improving high school graduation rates, or helping high school pupils to achieve college and career readiness" and "underachieving students, those from groups underrepresented in postsecondary education, those who are seeking advanced studies while in high school, and those seeking a career technical education credential or certificate" are eligible to participate in CCAP courses hosted at a SCHOOL DISTRICT site. (Education Code § 76004, subdivision (a); Assembly Bill 288 (2015) Section I, subdivision (d))

- 3.2. **Student Selection and Enrollment.** Enrollment shall be open to all eligible students as part of the CCAP Agreement who have been admitted to the COLLEGE and who meet all applicable prerequisites. Student selection criteria will be further specified in the CCAP Agreement Appendix C. Applicable prerequisite courses, training, or experience and standards required as preparation for courses offered through the CCAP Agreement will be determined by COLLEGE and shall be in compliance with applicable law and COLLEGE standards and policies.
- 3.3. **College Admission and Registration.** Procedures for students participating in the CCAP Agreement shall be governed by the COLLEGE and shall be in compliance with the admissions and registration guidelines outlined in applicable law and COLLEGE policy.
- 3.4. **Records of Student Attendance.** All records of student attendance and achievement shall be submitted to COLLEGE periodically using the COLLEGE student information system or upon demand and shall be maintained by COLLEGE.
- 3.5. **Priority Enrollment.** Students enrolling in a CCAP course will have priority enrollment by virtue of their status. High school students enrolling in non-CCAP college courses will not be eligible for priority registration.
- 3.6. **Physical Education Courses.** As part of a CCAP Agreement, a participating community college district shall not provide physical education course opportunities to high school students or any other course opportunities that do not assist in the attainment of the goals associated with career technical education or preparation for transfer, improving high school graduation rates, or helping high school students achieve career and college readiness. (Ed. Code § 76004, subdivision (d)).
- 3.7. **Maximum Units.** Students participating under a CCAP Agreement may enroll in up to a maximum of 15 units per term, without exception, if all the following conditions specified in Assembly Bill 288, Sec. 2 (p)(1)(2)(3) are satisfied:
 - a. The units constitute no more than four community college courses per term.
 - b. The units are part of an academic program that is part of a CCAP partnership agreement established pursuant to this article.
 - c. The units are part of an academic program that is designed to award students both a high school diploma and an associate degree or a certificate or credential.
- 3.8. **Minimum School Day.** The SCHOOL DISTRICT shall certify that it shall teach SCHOOL DISTRICT students participating as part of a CCAP Agreement no less than the number of instructional minutes required to complete a minimum school day pursuant to Education Code sections 46141 and 46142.
- 3.9. **Enrollment Restriction.** COLLEGE reserves the right to block students from enrolling in any courses for students who incur an unpaid debt for a non-CCAP class at the college.

COLLEGE agrees to remove the enrollment block when debt is paid in full.

4. COLLEGE APPLICATION PROCEDURE

- 4.1. The COLLEGE will be responsible for processing student applications.
- 4.2. The COLLEGE will provide the necessary admission and registration forms and procedures, and both COLLEGE and SCHOOL DISTRICT will jointly ensure that each applicant accepted has met all the enrollment requirements.
- 4.3. The SCHOOL DISTRICT agrees to assist COLLEGE in the admission and registration of SCHOOL DISTRICT students as may be necessary and requested by COLLEGE.

5. PARTICIPATING STUDENTS

- 5.1. The total cost of books and instructional materials for SCHOOL DISTRICT students who enroll in a COLLEGE course offered as part of this CCAP Agreement will be borne by SCHOOL DISTRICT.
- 5.2. The SCHOOL DISTRICT will ensure that ancillary and support services are accessible to students (e.g., Tutoring.). Student support services will not be provided by the COLLEGE.
- 5.3. A student taking courses under this CCAP Agreement with an Individual Education Plan or 504 Plan with the SCHOOL DISTRICT may request accommodation for his or her disability to participate in the educational programs and activities required by the COURSE and COLLEGE. Accommodation required by state law or SCHOOL DISTRICT policy will be provided through SCHOOL DISTRICT in consultation with the COLLEGE Learning Assistance Program (LAP) Office. Students requesting services by the LAP office will need to follow the standard process for requesting accommodations.

6. CCAP AGREEMENT COURSES

- 6.1. The COLLEGE may limit enrollment in a community college course solely to eligible high school students if the course is offered at a high school campus during the regular school day and the community college course is offered pursuant to this CCAP Agreement.
- 6.2. The COLLEGE is responsible for all courses and educational programs offered as part of CCAP Agreement .
- 6.3. The scope, nature, time, location, and listing of courses offered by a COLLEGE shall be determined by COLLEGE in consultation with the SCHOOL DISTRICT and with the approval of the COLLEGE and will be recorded in the Appendix C to this CCAP Agreement.
- 6.4. Courses offered as part of a CCAP Agreement shall be jointly selected and approved by COLLEGE and SCHOOL DISTRICT.
- 6.5. Courses offered as part of this CCAP Agreement shall have a minimum enrollment of fifteen (15) students.
- 6.6. The SCHOOL DISTRICT confirms that each approved CCAP course is held for no less than 50 minutes each class day in full compliance with the course outcomes determined by the COLLEGE.
- 6.7. Degree and certificate programs that are included in the CCAP agreement must have been

approved by the California Community College Chancellor's Office and courses offered at the SCHOOL DISTRICT shall adhere to the official course outline of record and the student learning outcomes established by the associated academic department within the COLLEGE, approved by the COLLEGE Academic Policy & Planning (AP&P) Committee and submitted to the Chancellor's Office. Course outlines will be provided to the SCHOOL DISTRICT.

- 6.8. Courses must meet the number of hours sufficient to meet the stated performance objectives as outlined in the course outlines provided to the SCHOOL DISTRICT on a semester basis.
- 6.9. Courses offered at the SCHOOL DISTRICT as part of this CCAP Agreement shall be of the same quality and rigor as those offered on the COLLEGE campus and shall be in compliance with COLLEGE academic standards.
- 6.10. Courses offered as part of this CCAP Agreement will comply with all applicable regulations, policies, procedures, prerequisites, and standards applicable to the COLLEGE as well as any corresponding policies, practices, and requirements of the SCHOOL DISTRICT. In the event of a conflict between the COLLEGE course related regulations, policies, procedures, prerequisites and standards and SCHOOL DISTRICT policies, practices and requirements, the COLLEGE regulations, policies, procedures, prerequisites, and standards, shall prevail.
- 6.11. A student's withdrawal prior to completion of a course offered as part of this CCAP Agreement shall be in accordance with COLLEGE guidelines, policies, pertinent statutes and regulations.
- 6.12. Supervision and evaluation of students enrolled in courses offered as part of this CCAP Agreement shall be in accordance with COLLEGE guidelines, policies, pertinent statutes and regulations.
- 6.13. COLLEGE has the sole right to control and direct the instructional activities for all CCAP Agreement courses and all instructors, including those who are SCHOOL DISTRICT employees.
- 6.14. This CCAP Agreement certifies that any remedial course taught by community college faculty at a partnering high school campus shall be offered only to high school students who do not meet their grade level standard in math, English, or both on an interim assessment in grade 10 or 11, as determined by the partnering SCHOOL DISTRICT, and shall involve collaborative effort between the SCHOOL DISTRICT and the COLLEGE faculty to deliver an innovative remediation course as an intervention in the student's junior or senior year to ensure the student is prepared for college-level work upon graduation.
- 6.15. CCAP Agreement Courses outlined in Appendix C shall be updated annually and approved before the start of each academic year.

7. INSTRUCTORS

- 7.1. All instructors teaching COLLEGE courses offered as part of this CCAP Agreement must meet the minimum qualifications for instruction in a California community college as set forth in Title 5 California Code of Regulations, Sections 53410 and 58060 or as amended.
- 7.2. The CCAP Agreement Appendix C shall specify which participating SCHOOL DISTRICT or COLLEGE will be the employer of record for purposes of assignment monitoring and

- reporting to the county office of education.
- 7.3. This CCAP Agreement specifies that the SCHOOL DISTRICT will assume reporting responsibilities pursuant to applicable federal teacher quality mandates.
 - 7.4. Instructors who teach COLLEGE courses offered as part of this CCAP Agreement must provide the supervision and control reasonably necessary for the protection of the health and safety of students and may not have any other assigned duty during the instructional activity.
 - 7.5. Instructors who teach COLLEGE courses shall comply with the fingerprinting requirements set forth in Education Code section 45125 or as amended and the tuberculosis testing and risk assessment requirements of California Health and Safety Code section 121525 or as amended. In addition to any other prohibition or provision, no person who has been convicted of a violent or serious felony shall be eligible to teach any courses offered as part of this CCAP Agreement or otherwise provide services on a SCHOOL DISTRICT site. SCHOOL DISTRICT shall immediately notify COLLEGE if an instructor is charged with an offense prohibited by Education Code sections 44010 or 44011.
 - 7.6. Prior to teaching, faculty provided by the SCHOOL DISTRICT shall participate in required discipline-specific training and orientation from COLLEGE regarding, but not limited to, course curriculum, assessment criteria, pedagogy, course philosophy, testing and grading procedures record keeping, and other instructional responsibilities. Such training shall be approved and provided by the COLLEGE.
 - 7.7. Prior to teaching, instructors provided by the COLLEGE may receive training and orientation from SCHOOL DISTRICT regarding, but not limited to, SCHOOL DISTRICT policies, practices, and requirements. Such training may be approved and provided by the SCHOOL DISTRICT.
 - 7.8. Faculty provided by the SCHOOL DISTRICT are eligible to participate in professional development activities sponsored by the COLLEGE as required by the terms and conditions of the contract and shall be encouraged to participate in ongoing collegial interaction to include, but not limited to, addressing course content, course delivery, assessment, evaluation, and/or research and development in the field.
 - 7.9. The COLLEGE shall evaluate faculty performance for the college courses using the adopted evaluation of process and standards for faculty of the COLLEGE, subject to the approval of COLLEGE.
 - 7.10. The COLLEGE and SCHOOL DISTRICT will work collaboratively to identify instructors from SCHOOL DISTRICT who may meet minimum qualification requirements or local equivalency standards to teach a COLLEGE course and encourage them to apply for consideration. Instructors will be required to go through the COLLEGE screening process for possible selection and assignment to the course.
 - 7.11. The SCHOOL DISTRICT teachers approved to teach COLLEGE courses remain employees of the SCHOOL DISTRICT, subject to the authority of the SCHOOL DISTRICT, but will also be subject to the authority of COLLEGE specifically with regard to their duties as COLLEGE instructors, pursuant to the terms of Appendix A.
 - 7.12. The COLLEGE shall determine the number of instructors, the ratio of instructors to students, and the subject areas of instruction.
 - 7.13. Faculty provided by the SCHOOL DISTRICT who do not comply with the policies, regulations, standards, and expectations of the COLLEGE shall be ineligible to teach college

courses under this CCAP Agreement.

- 7.14. SCHOOL DISTRICT teachers approved to teach CCAP Courses under this CCAP Agreement must submit grades to both the COLLEGE and SCHOOL DISTRICT using the COLLEGE student information system by the established timeline (Appendix D).
- 7.15. SCHOOL DISTRICT teachers approved by the COLLEGE shall sign an Agreement with the Instructor (Appendix A) prior to the start of each academic year.
- 7.16. SCHOOL DISTRICT teachers approved by the COLLEGE shall provide support to high school students taking COLLEGE courses under CCAP agreement with COLLEGE admission and registration procedures.

8. ASSESSMENT OF LEARNING AND CONDUCT

- 8.1. Students enrolled in COLLEGE courses offered as part of this CCAP Agreement at the SCHOOL DISTRICT shall be held to the same standards of achievement as students in courses taught on the COLLEGE campus.
- 8.2. Students enrolled in COLLEGE courses offered as part of this CCAP Agreement at the SCHOOL DISTRICT shall be held to the same grading standards as those expected of students in courses taught on the COLLEGE campus.
- 8.3. Students enrolled in COLLEGE courses offered as part of this CCAP Agreement at the SCHOOL DISTRICT shall be assessed using the same methods (e.g., papers, portfolios, quizzes, labs, etc.) as students in courses taught on the COLLEGE campus.
- 8.4. Students enrolled in COLLEGE courses offered as part of this CCAP Agreement at the SCHOOL DISTRICT shall be held to the same behavioral standards as those expected of students in courses taught on the COLLEGE campus.

9. LIAISON AND COORDINATION OF RESPONSIBILITIES

- 9.1. The COLLEGE shall appoint an educational administrator who will serve as point of contact to facilitate coordination and cooperation between COLLEGE, SCHOOL DISTRICT, and HIGH SCHOOL in conformity with COLLEGE policies and standards. (Ed. Code, § 76004, subd. (c)(2).) Among other things, the COMMUNITY COLLEGE DISTRICT Educational Administrator and the SCHOOL DISTRICT Educational Administrator described in Section 9.2, shall collaborate to determine the process for timely receiving, investigating, and remediating complaints of sexual misconduct or other conduct covered by Title IX of the Education Amendments of 1972 alleged to have occurred in or related to the CCAP program.
- 9.2. The SCHOOL DISTRICT shall appoint an educational administrator who will serve as point of contact to facilitate coordination and cooperation between SCHOOL DISTRICT, COLLEGE, HIGH SCHOOL in conformity with SCHOOL DISTRICT policies and standards.
- 9.3. This CCAP Agreement requires an annual report to the office of the Chancellor of the California Community Colleges by COLLEGE and SCHOOL DISTRICT. COLLEGE shall complete and file the Apportionment Attendance Report (CCFS-320); SCHOOL DISTRICT agrees to provide the following information, when requested by COLLEGE, in accordance with AB 288 Section 2, Education Code Section 76004:
 - a. The total number of high school students by school site enrolled in each partnership,

aggregated by gender and ethnicity, and reported in compliance with all applicable state and federal privacy laws.

- b. The total number of community college courses by course category and type and by school site enrolled in by CCAP partnership participants.
- c. The total number and percentage of successful course completions, by course category and type and by school site, of CCAP partnership participants.
- d. The total number of full-time equivalent students generated by CCAP partnership community college district participants.

10. DISPUTES

10.1. COLLEGE and SCHOOL DISTRICT recognize that, from time to time, disputes may arise between COLLEGE employees or students and SCHOOL DISTRICT employees or students. When such disputes arise, COLLEGE and SCHOOL DISTRICT shall collaborate and use their best efforts to resolve them informally. Where informal resolution is not successful or the PARTIES must address a formal inter-agency complaint, the following process will be utilized to resolve the matter.

- a. The PARTY receiving the complaint will timely notify the other, and promptly provide the other PARTY with any written complaint received.
- b. The Educational Administrators will review the complaint to determine, based on the nature of the complaint, whether any statutory or regulatory timelines or other procedural requirements apply, including but not limited to:

10.1.b.1. Whether COLLEGE is required to investigate the complaint to the State Chancellor pursuant to Title 5 of the California Code of Regulations.

10.1.b.2. Whether, based on the nature of the complaint, the complainant is entitled to any rights or protections with regard to how the complaint is handled, pursuant to Title 5 or applicable state or federal laws, including but not limited to Title IX of the Education Amendments of 1972.

10.1.b.3. If either Educational Administrator finds such rights to exist, he or she shall notify the other Educational Administrator, and COLLEGE and SCHOOL DISTRICT shall cooperate as needed in carrying out these requirements. It is understood that such requirements may include but are not limited to conducting a formal investigation within regulatory timelines or the implementation of interim safety measures for the complainant.

- c. Within a reasonable time, either PARTY receiving the complaint, the PARTIES will discuss the nature and severity of the allegations and come to a mutual agreement regarding the need for and scope of any investigation required. If it is agreed that a formal investigation is required, the PARTIES will mutually agree upon an investigator, who may be an outside investigator, or qualified employee of COLLEGE or SCHOOL DISTRICT. If the PARTIES agree to have the matter investigated internally by either a COLLEGE or SCHOOL DISTRICT employee, the other PARTY may designate an employee to attend all witness interviews. Where it is determined that an outside investigator will be used, the cost will be divided between the PARTIES.
- d. If, despite the good faith effort of the PARTIES, they are unable to agree on a process

for investigating the complaint, the PARTY whose employee/student is the subject of the complaint will determine the process.

- e. The COLLEGE and SCHOOL DISTRICT will cooperate in any investigation initiated and make its employees available to the investigator.
- f. Interviews of COLLEGE and SCHOOL DISTRICT employees shall comply with any rights and protections afforded to them under an applicable collective bargaining agreement or state or federal law, including but not limited to the right to have a representative present during an interview that could lead to discipline.
- g. The investigator will prepare a report that will be provided to both PARTIES setting forth findings as to the allegations and the basis for the findings.
- h. The COLLEGE and SCHOOL DISTRICT shall share any and all materials from the investigation, unless sharing would cause a PARTY to violate confidentiality or privacy laws.
- i. The COLLEGE and SCHOOL DISTRICT have sole discretion in determining any disciplinary measures to be imposed against their respective employees or students.
- j. Regardless of any disciplinary measures taken by the COLLEGE or SCHOOL DISTRICT against its respective employees or students, the other PARTY retains the right to have the subject of a sustained complaint removed from participating in or providing services for the program that is the subject of this CCAP Agreement.

11. APPORTIONMENT

- 11.1. COLLEGE shall include the students enrolled in a CCAP Agreement course in its report of full-time equivalent students (FTES) for purposes of receiving state apportionments when the course(s) complies with current requirements for dual enrollment under applicable California law.
- 11.2. For purposes of allowances and apportionments from Section B of the State School Fund, a community college district conducting a closed course on a high school campus shall be credited with those units of full-time equivalent students attributable to the attendance of eligible high school pupils.
- 11.3. The COLLEGE shall not receive a state allowance or apportionment for an instructional activity for which the SCHOOL DISTRICT has been, or shall be, paid an allowance or apportionment. (Ed. Code § 76004, subdivision (o)(2)).
- 11.4. The attendance of a SCHOOL DISTRICT pupil at the COLLEGE as a special part-time or full-time student pursuant to this section is authorized attendance for which the COLLEGE shall be credited or reimbursed pursuant to Section 48802 or 76002, provided that no school district has received reimbursement for the same instructional activity.

12. CERTIFICATIONS

- 12.1. The SCHOOL DISTRICT certifies that:
 - a. The direct education costs of the courses offered as part of this CCAP Agreement are not fully funded through other sources.
 - b. It agrees and acknowledges that the COLLEGE will claim apportionment for the

SCHOOL DISTRICT students enrolled in community college course(s) under this CCAP Agreement.

- c. Any COLLEGE instructor teaching a course at the SCHOOL DISTRICT has not displaced or resulted in the termination of an existing high school teacher teaching the same course on that high school campus.

12.2. The COLLEGE certifies that:

- a. A community college course offered for college credit at the participating SCHOOL DISTRICT does not reduce access to the same course offered at the partnering COLLEGE.
- b. The COLLEGE has not received full compensation for the direct education costs for the conduct of the courses offered as part of this CCAP Agreement from other sources.
- c. The Agreement is consistent with the core mission of the COLLEGE pursuant to Section 66010.4 and students participating in this CCAP Agreement will not lead to displacement of otherwise eligible adults at the COLLEGE.
- d. A qualified SCHOOL DISTRICT instructor teaching a course offered for college credit at a high school campus has not displaced or resulted in the termination of an existing COLLEGE faculty member teaching the same course at the partnering community college campus.

12.3. The PARTIES certify that:

- a. Any COLLEGE instructor teaching a course on a SCHOOL DISTRICT campus has not been convicted of any sex offense as defined in Education Code section 44010 or as amended, or any controlled substance offense as defined in Education Code section 44011 or as amended.
- b. The SCHOOL DISTRICT and COLLEGE comply with local collective bargaining agreements and all state and federal reporting requirements regarding the qualifications of the teacher or faculty member teaching a CCAP Agreement course offered for high school credit. (AB288 Sec. 2 (I).)

13. PROGRAM IMPROVEMENT

- 13.1. The COLLEGE and the SCHOOL DISTRICT may annually conduct surveys of participating SCHOOL DISTRICT pupils, instructors, principals, and school counselors for the purpose of informing practice, adjusting, and improving the quality of courses offered as part of this CCAP Agreement.

14. RECORDS

- 14.1. Permanent records of student attendance, grades and achievement will be maintained by both the SCHOOL DISTRICT and COLLEGE for SCHOOL DISTRICT students who enroll in course(s) offered as part of this CCAP Agreement. Permanent records of student enrollment, grades, and achievement for COLLEGE students shall be maintained by COLLEGE.

- 14.2. Each PARTY shall maintain records pertaining to this CCAP Agreement as may be required by federal and state law. Each PARTY may review and obtain a copy of the other PARTY'S pertinent records subject to federal and state privacy statutes.
- 14.3. SCHOOL DISTRICT instructors will submit grades to the COLLEGE when due according to the COLLEGE schedule per section 7.14. The SCHOOL DISTRICT will include all criteria identified by the COLLEGE for grading purposes.
- 14.4. COLLEGE may provide the SCHOOL DISTRICT with a report on participating students' final grades after each term.

15. CCAP AGREEMENT DATA MATCH AND REPORTING

- 15.1. COLLEGE and SCHOOL DISTRICT shall ensure operational protocols consistent with the collection of participating student data and the timely submission of the data.
- 15.2. COLLEGE shall report all program and participating student data to the office of the Chancellor of the California Community Colleges.

16. DATA SHARING

- 16.1. COLLEGE and SCHOOL DISTRICT may share confidential student data for the purposes of evaluating the educational services provided under this CCAP agreement and for evaluating student performance pursuant to participating in CCAP courses. Any data shared will be for research and analytical purposes aimed at understanding student performance and improving applicable federal and state laws concerning access to and confidentiality of student record information as described in Section 17 of this agreement.

17. PRIVACY OF STUDENT RECORDS

- 17.1. COLLEGE and SCHOOL DISTRICT understand and agree that education records of students enrolled in a CCAP course and personally identifiable information contained in those educational records are subject to the Family Educational Rights and Privacy Act (FERPA) 20 U.S.C. § 1232g; 34 C.F.R. Part 99, including the disclosure provisions of § 99.30 and state law as outlined in Education Code section 49064 and section 49076). COLLEGE and SCHOOL DISTRICT agree to hold all student education records generated pursuant to this CCAP Agreement in strict confidence and further agree not to disclose such records except as authorized by applicable law or regulation for COLLEGE records or by the parent or guardian's prior written consent for HIGH SCHOOL records. (34 C.F.R. § 99.33 (a), (b); 34 C.F.R. § 99.34(b) and Education Code §§ 49064 and 49076.)
- 17.2. **Limitation on Use.** COLLEGE and SCHOOL DISTRICT shall use each student education record that they may receive pursuant to this CCAP Agreement solely for purposes consistent with their authority to access that information pursuant to Federal and State law, as may be as applicable. (34C.F.R. § 99.31, 34 C.F.R. § 99.34, and Education Code § 49076.)
- 17.3. **Recordkeeping Requirements.** COLLEGE and SCHOOL DISTRICT shall comply with the requirements governing maintenance of records of each request for access to and each disclosure of student education records set forth under Title 34, Code of Federal Regulations § 99.32 and under Education Code § 49064 as applicable.
- 17.4. **Acknowledgement of Receipt of Notice of FERPA Regulations.** By signature of

its authorized representative or agent on this Agreement, COLLEGE and SCHOOL DISTRICT hereby acknowledges that it has been provided with the notice required under 34 C.F.R. § 99.33(d) that it is strictly prohibited from re-disclosing student education records to any other person or entity except as authorized by applicable law or regulation. Parent or guardian requests for information will need to be addressed directly by the HIGH SCHOOL or SCHOOL DISTRICT personnel.

18. REIMBURSEMENT

- 18.1. The SCHOOL DISTRICT shall invoice the COLLEGE no later than 30 (thirty) days after the start of each term for the instructional services provided through this CCAP agreement as follows:

For courses taught by COLLEGE-approved SCHOOL DISTRICT teachers and COLLEGE instructors on HIGH SCHOOL campuses during regular high school hours rendered at the rate of \$1,000.00 per course unit delivered to CCAP students.

Example: 3 CCAP courses @ 3 units each = 9 units x \$1,000.00 = \$9,000.00

- 18.2. The COLLEGE shall make payment to the SCHOOL DISTRICT within 30 days of receiving the invoice for instructional services rendered.
- 18.3. The COLLEGE is required to report to the state the percentage of funds paid to an agency to the SCHOOL DISTRICT that will provide direct instruction on behalf of the college as part of the CCAP partnership agreement. The SCHOOL DISTRICT will use 100% of all funds received from Allan Hancock College in fulfillment of this agreement to pay for direct instructional costs. (Ed. Code § 84632).

19. FACILITIES

- 19.1. The SCHOOL DISTRICT will provide adequate classroom space at its facilities or other mutually agreed upon locations to conduct the instruction and do so without charge to COLLEGE or students. SCHOOL DISTRICT agrees to clean, maintain, and safeguard SCHOOL DISTRICT's premises. SCHOOL DISTRICT warrants that its facilities are safe and compliant with all applicable buildings, fire, and safety codes.
- 19.2. The SCHOOL DISTRICT will furnish, at its own expense, all course materials, specialized equipment, books and other necessary equipment for all SCHOOL DISTRICT students. The parties understand that such equipment and materials are the SCHOOL DISTRICT's sole property.
- 19.3. The SCHOOL DISTRICT facilities may be used by COLLEGE for COLLEGE course offerings before or after regular high school schedule at no additional cost. Prior approval by the SCHOOL DISTRICT is required. COLLEGE courses offered before or after the regular high school schedule will be open to the public.

20. INDEMNIFICATION

- 20.1. The SCHOOL DISTRICT agrees to and shall indemnify, save and hold harmless the

COLLEGE, and its governing board, officers, employees, administrators, independent contractors, subcontractors, agents and other representatives from any and all claims, demands, liabilities, costs, expenses, damages, causes of action, losses, and judgments, arising out of SCHOOL DISTRICT's performance of this CCAP Agreement. The obligation to indemnify shall extend to all claims and losses that arise out of SCHOOL DISTRICT's or its trustees', officers', agents', or employees' negligence, wrongful acts or omissions, or willful misconduct related to this CCAP Agreement or performance of this CCAP Agreement. The provisions of this section shall survive the termination or expiration of this CCAP Agreement.

20.2. The COLLEGE agrees to and shall indemnify, save and hold harmless the SCHOOL DISTRICT and its governing board, officers, employees, administrators, independent contractors, subcontractors, agents and other representatives from any and all claims, demands, liabilities, costs, expenses, damages, causes of action, losses, and judgments, arising out of COLLEGE'S performance of this CCAP Agreement. The obligation to indemnify shall extend to all claims and losses that arise out of COLLEGE'S or its trustees', officers', agents', or employees' negligence, wrongful acts or omissions, or willful misconduct related to this CCAP Agreement or performance of this CCAP Agreement. The provisions of this section shall survive the termination or expiration of this CCAP Agreement.

21. INSURANCE

21.1. The SCHOOL DISTRICT, in order to protect the COLLEGE, its agents, employees and officers against claims and liability for death, injury, loss and damage arising out of or in any manner connected with the performance and operation of the terms of this CCAP Agreement, shall secure and maintain in force during the entire term of this CCAP Agreement, insurance coverage or an approved program of self-insurance in the amount of not less than ONE MILLION DOLLARS (\$1,000,000) per incident and TWO MILLION DOLLARS (\$2,000,000) general aggregate for personal injury, bodily injury, death, and property and other damage, with an admitted California insurer duly licensed to engage in the business of insurance in the State of California, or public entity risk management Joint Powers Authority, authorized to provide public liability and property damage insurance in the state of California. Said policy of insurance, insurance coverage through a public entity risk management JPA, or program of self-insurance shall expressly name the COLLEGE, its agents, employees and officers as an additional insured for the purposes of this CCAP Agreement. A certificate of insurance including such endorsement shall be furnished to the COLLEGE.

21.2. The COLLEGE, in order to protect the SCHOOL DISTRICT, its agents, employees and officers against claims and liability for death, injury, loss and damage arising out of or in any manner connected with the performance and operation of the terms of this CCAP Agreement, shall secure and maintain in force during the entire term of this CCAP Agreement, insurance coverage or an approved program of self-insurance in the amount of not less than ONE MILLION DOLLARS (\$1,000,000) per incident and TWO MILLION DOLLARS (\$2,000,000) general aggregate for personal injury, bodily injury, death, and property and other damage, with an admitted California insurer duly licensed to engage in the business of insurance in the State of California, or public entity risk management Joint Powers

Authority, authorized to provide public liability and property damage insurance in the State of California. Said policy of insurance, insurance coverage through a public entity risk management JPA or program of self-insurance shall expressly name the SCHOOL DISTRICT, its agents, employees and officers as an additional insured for the purposes of this CCAP Agreement. A certificate of insurance including such endorsement shall be furnished to the SCHOOL DISTRICT.

- 21.3. For the purpose of Workers' Compensation, SCHOOL DISTRICT shall be the "primary employer" for all its employees who perform services as instructors and support staff. SCHOOL DISTRICT shall be solely responsible for processing, investigating, defending, and paying all workers' compensation claims by their respective SCHOOL DISTRICT employees made in connection with performing services and receiving instruction under this CCAP Agreement. SCHOOL DISTRICT agrees to hold harmless, indemnify, and defend COLLEGE, its directors, officers, agents, and employees from any liability resulting from its failure to process, investigate, defend, or pay any workers' compensation claims by SCHOOL DISTRICT employees connected with providing services under this CCAP Agreement.

22. NON-DISCRIMINATION

- 22.1. Neither the SCHOOL DISTRICT nor the COLLEGE shall discriminate on the basis of race or ethnicity, gender, nationality, physical or mental disability, sexual orientation, religion, or any other protected class under California State or federal law.

23. NOTICES

- 23.1. Any and all notices required to be given hereunder shall be deemed given when personally delivered or deposited in the U.S. Mail, postage to be prepaid, to the following addresses:

Allan Hancock College Joint Community College District
800 S. College Drive
Santa Maria, CA 93460
Attn: Dennis Curran

Gateway Community Charters
Address: 5112 Arnold Ave Suite A, McClellan Park, CA 95652
Attn: Jason Sample

24. MODIFICATION AND AMENDMENT

- 24.1. Appendix A through D to this CCAP Agreement is incorporated by this reference into this CCAP Agreement.
- 24.2. This CCAP Agreement and Appendix A through D to this CCAP Agreement set forth the entire agreement between the PARTIES relating to the subject matter of this CCAP Agreement. This CCAP Agreement and Appendix A through D to this CCAP Agreement supersede any prior agreements, promises, negotiations, or representations, express or

implied, oral or written, not included in this CCAP Agreement and Appendix A through D to this CCAP Agreement.

24.3. This Agreement may be amended only with the mutual consent of the Parties. All amendments must be in writing and must be approved by the Parties' respective governing Boards.

25. GOVERNING LAWS

25.1. This CCAP Agreement will be governed by and construed in accordance with California law, and the venue of any action or proceeding in connection with this CCAP Agreement shall be Santa Barbara County, California.

26. COMMUNITY COLLEGE DISTRICT BOUNDARIES

26.1. For locations outside the geographical boundaries of Allan Hancock College Joint Community College District, the COLLEGE will comply with the requirements of Title 5 of the California Code of Regulations, Sections 55300 et seq. or as amended, concerning approval by adjoining high school or community college districts and use of non-district facilities.

27. SEVERABILITY

27.1. This CCAP Agreement shall be considered severable, such that if any provision or part of the CCAP Agreement is ever held invalid under any law or ruling, that provision or part of the CCAP Agreement shall remain in force and effect to the extent allowed by law, and all other provisions or parts shall remain in full force and effect.

28. COUNTERPARTS

28.1. This CCAP Agreement may be executed by the PARTIES in separate counterparts, each of which when so executed and delivered shall be an original, but all such counterparts shall together constitute one and the same instrument.

IN WITNESS WHEREOF, the PARTIES hereto have caused this CCAP Agreement to be executed on the dates set forth below, to be effective as of the Effective Date.

ALLAN HANCOCK JOINT COMMUNITY
COLLEGE DISTRICT

GATEWAY COMMUNITY CHARTERS

By: _____
Associate Superintendent/Vice President of
Finance and Administration

By: _____
Superintendent/CEO

Date: _____

Date: _____

ALLAN HANCOCK JOINT COMMUNITY
COLLEGE DISTRICT BOARD MEETINGS

GATEWAY COMMUNITY CHARTERS
SCHOOL DISTRICT BOARD MEETINGS

Information Board Meeting Date:

Information Board Meeting Date:

Public Comment
and Approval Board Meeting Date:

Public Comment
and Approval Board Meeting Date:

APPENDIX A

ALLAN HANCOCK COLLEGE JOINT COMMUNITY COLLEGE DISTRICT

Agreement with INSTRUCTOR

This agreement is made and entered into this _____ [day] of _____ [month] ____ [year] by three parties: The Allan Hancock College Joint Community College District (hereinafter “COLLEGE”), the _____ [high school district] (hereinafter “SCHOOL DISTRICT”) and _____ [first name, last name], an employee of the SCHOOL DISTRICT (hereinafter “INSTRUCTOR”) who is being assigned to the COLLEGE on a part-time basis pursuant to Title 5, California Code of Regulations, section 58058(b).

WHEREAS, the SCHOOL DISTRICT has the experience, training, equipment and other resources, and staff necessary to provide instruction to COLLEGE students through the CCAP Agreement;

WHEREAS, Title 5, California Code of Regulations, section 58050, subdivision (a) provides authority for claiming apportionment;

NOW, THEREFORE, the three parties to this Agreement hereby agree as follows:

1. The SCHOOL DISTRICT’s INSTRUCTOR is an employee of the SCHOOL DISTRICT who shall meet “Minimum Qualifications” for the academic position of COLLEGE’s INSTRUCTOR as established by the COLLEGE and as determined by the COLLEGE.
2. The SCHOOL DISTRICT’s INSTRUCTOR is professionally and specially trained and competent to provide the supervisory and/or instructional services required by the COLLEGE.
3. The INSTRUCTOR will be an employee of the COLLEGE for purposes of the Attendance Accounting Standards (Ed. Code, § 58050). COLLEGE has the right to; 1) evaluate and terminate INSTRUCTOR; 2) evaluate the quality of instruction to ensure that it meets the needs of students; 3) evaluate the quality and rigor equal to the COLLEGE’S approved course outline of record and the accreditation requirements of COLLEGE. The COLLEGE will not provide INSTRUCTOR evaluation results to the SCHOOL DISTRICT.
4. The SCHOOL DISTRICT’s INSTRUCTOR shall at all times comply with the supervisory and/or instructional requirements outlined in Title 5, California Code of Regulations, section 58055, which require direct instruction by the SCHOOL DISTRICT’s INSTRUCTOR except in limited circumstances. The SCHOOL DISTRICT’s INSTRUCTOR’s responsibilities and duties as an employee of the COLLEGE shall include, but are not limited to, the following:
 - 4.1. Ensure that an instructional time of 50 minutes per class each day is expended in full compliance with the course objectives determined by the COLLEGE.
 - 4.2. Ensure the safety and well-being of students.
 - 4.3. Be in sufficient physical proximity and range of communication to provide immediate instructional supervision and control of all students in his/her classes.
 - 4.4. Attend periodic staff meetings with the COLLEGE.
 - 4.5. Regularly check and respond to communication from COLLEGE.
 - 4.6. Priority in class enrollment shall be given to students desiring to take the course for college credit towards a degree or certificate (Ed. Code § 76370). Ensure accurate and

current daily student attendance records, accurate calculation of final student grades of all students enrolled in the course for college credit, and the prompt submission of all data necessary for the calculation of FTES to the DISTRICT within 3 (three) calendar days of course completion (Ed. Code § 84500).

- 4.7. Ensure the effective use of instructional methods, technology, testing and remediation.
 - 4.8. Ensure that he/she does not have any other assigned duties during the instructional activity where multiple skill levels of students are being taught for which attendance is being claimed.
 - 4.9. Be familiar with and comply with all relevant COLLEGE policies, rules and regulations, including but not limited, to those related to student safety, grading, attendance, sexual harassment and discrimination.
 - 4.10. Provide support to SCHOOL DISTRICT students taking COLLEGE courses under CCAP agreement with COLLEGE admission and registration procedures.
5. The SCHOOL DISTRICT shall indemnify and hold harmless the COLLEGE and its authorized agents, officers, and employees against any and all claims and actions arising from the SCHOOL DISTRICT's INSTRUCTOR's or SCHOOL DISTRICT's negligent, reckless or intentional acts, errors or omissions and for any cost or expense incurred by the COLLEGE on account of any claim therefor.
 6. The COLLEGE shall provide no compensation to the SCHOOL DISTRICT's INSTRUCTOR for any services rendered pursuant to this Agreement, but compensation, as well as workers' compensation insurance, shall be the responsibility of the SCHOOL DISTRICT in accordance with its established and standard practices.
 7. This Agreement may be terminated at any time by the COLLEGE within the sole and exclusive discretion of the COLLEGE upon written notice to the SCHOOL DISTRICT and the SCHOOL DISTRICT's INSTRUCTOR. This Agreement may be terminated upon thirty (30) days' prior written notice to COLLEGE by either the SCHOOL DISTRICT or the SCHOOL DISTRICT's INSTRUCTOR within either's sole and exclusive discretion.

IN WITNESS WHEREOF, the parties hereto have executed this Agreement the day and year last written below.

INSTRUCTOR

ALLAN HANCOCK COLLEGE JOINT
COMMUNITY COLLEGE DISTRICT

Print

Print

Signature

Signature

APPENDIX B

Identification of CCAP Pathways for Course-Specific College and Career Pathway Opportunities

Pursuant to California Assembly Bill No. 288, the COLLEGE and SCHOOL DISTRICT enter into this partnership agreement to offer College and Career Pathways (CCAP) to high school students to expand dual enrollment opportunities to facilitate college and career readiness, particularly among students who may not already be college-bound or who are underrepresented in higher education.

The goal of the CCAP partnership is to offer seamless pathways from high school to community college to promote: 1) academic preparation for transfer to four-year colleges and universities; 2) completion of career and technical education programs for entry into the workforce; (3) improving high school graduation rates, and (4) helping high school pupils achieve college and career readiness.

The following pathways are included in the CCAP partnership agreement between the COLLEGE and SCHOOL DISTRICT:

Career and Technical Education:

1. This pathway includes COLLEGE courses in a Career and Technical education (“CTE”) pathway at the college level that apply to an Allan Hancock College degree or certificate in the pathway. This includes:
 - a. Naming of HIGH SCHOOL Pathway and Course Location in Sequence (Introductory, Concentrator, Capstone, or Practicum)
 - b. Naming of COLLEGE Pathway – Degree or Certificate
 - c. Identifying Career/Employment Outcomes associated with CTE Pathway
 - d. Identifying the course(s) in the Pathway to be offered under the CCAP Agreement.
2. Examples of CTE Technical Pathways include Automotive, Digital Art and Graphic Design, Culinary, Early Childhood Studies, Welding etc.

College and Career Readiness:

1. This pathway includes COLLEGE courses in career exploration and career development that prepare students in college and career planning. Successful completion of these courses will allow students to matriculate at college level in courses in a CTE pathway or General Education/California State University (“CSU”) Transfer pathway.
2. Course examples include: WEE (Work Experience); PD (Career Planning).

Preparation for Transfer:

1. California General Education Transfer Curriculum (Cal-GETC). This pathway includes COLLEGE courses which have been approved to meet the lower-division general education requirements at any CSU or University of California campus (i.e. Areas 1-6)

Improve High School Graduation Rates:

1. Student participation in college courses improves graduation rates of students who participate compared to peers who do not participate in college-level coursework.

APPENDIX C

CCAP Agreement Courses Approved for 2025-2026

HIGH SCHOOL DISTRICT:

GATEWAY COMMUNITY CHARTERS

HIGH SCHOOL SITE / LOCATION:

SACRAMENTO ACADEMIC & VOCATIONAL ACADEMIES

PROJECTED NUMBER OF STUDENTS TO BE SERVED: **120**

TOTAL PROJECTED FTES: **12.36**

CCAP Pathway	College Degree or Certificate	High School Pathway	CCAP Course Offerings		Number of Sections, High School period(s) & Times		Instructor Name & Employer of Record (AHC or HS)		Projected Number of Students	Projected FTES
			FALL	SPRING	FALL	SPRING	FALL	SPRING		
College & Career Readiness	AA GE	College & Career Readiness	PROD 301	High school course	1 Periods & Times (TBD)	1 Periods & Times (TBD)	Julie Carter (HS)	Julie Carter (HS)	30	3.09
College & Career Readiness	AA GE	College & Career Readiness	PROD 301	High school course	1 Periods & Times (TBD)	2 Periods & Times (TBD)	Season Turner (HS)	Season Turner (HS) Stephen Webster (HS)	30	3.09
College & Career Readiness	AA GE	College & Career Readiness	PROD 301	High school course	0 Periods & Times (TBD)	1 Periods & Times (TBD)	N/A	Camilo Rodriguez (HS)	30	3.09
College & Career Readiness	AA GE	College & Career Readiness	PROD 301	High school course	0 Periods & Times (TBD)	1 Periods & Times (TBD)	N/A	Casey Mathews (HS)	30	3.09

1. **REQUIRED:** Describe the criteria used to assess the ability of pupils to benefit from the course(s) offered:

In consultation with their SCHOOL DISTRICT counselors, students self-select a pathway based on their academic readiness and alignment of course content to students' educational and career goals. SCHOOL DISTRICT and COLLEGE faculty identified CCAP courses using the following criteria:

- a. Alignment with HIGH SCHOOL pathways and COLLEGE programs of study.

- b. Potential for course completion to accelerate students' time to completion of postsecondary degree or certificate.
- c. Potential to earn a Certificate of Training and be eligible to enter the workforce in their selected career technical pathway.
- d. Potential to work toward completion of an associate degree or an associate degree for transfer.

2. **MINIMUM QUALIFICATIONS FOR INSTRUCTION:** All instructors teaching CCAP Agreement Courses must meet the minimum qualifications for instruction in a California community college as set forth in Title 5 of the California Code of Regulations, sections 53410 and 58060 or as amended. The minimum qualifications for instruction are:

Course Name & Number	Minimum Qualifications For Instructors
PROD 301	<ul style="list-style-type: none"> • Master's degree in counseling, rehabilitation counseling, clinical psychology, counseling psychology, guidance counseling, educational counseling, social work, career development, marriage and family therapy, or marriage, family, and child counseling • OR the equivalent <p>NOTE: A bachelor's degree in one of the listed degrees and a license as a Marriage and Family Therapist (MFT) is an alternative qualification for this discipline</p> <ul style="list-style-type: none"> • OR master's degree in education • OR any bachelor's degree or higher and two years of professional experience in Office Technologies • OR any associate degree and six years of professional experience in Office Technologies. <p>NOTE: Professional experience is required when the application possesses a master's degree. The professional experience required must be directly related to the teaching assignment.</p>

3. **BOOKS AND INSTRUCTIONAL MATERIALS:** The total cost of books and instructional materials for SCHOOL DISTRICT students participating in CCAP course as part of this CCAP Agreement will be borne by SCHOOL DISTRICT. The cost estimate is based on the current pricing and additions.

COURSE NAME &	TEXTBOOK	COST	OTHER INSTRUCTIONAL	COST
---------------	----------	------	---------------------	------

NUMBER			MATERIALS
PROD 301	Career Choices and Changes, M. Bingham, S. Stryker, 6 th Edition (2019)	\$59.95	My10yearPlan.com \$35

4. **JOINT FACILITIES USE PROTOCOLS:** COLLEGE and SCHOOL DISTRICT shall adhere to the terms and protocols outlined in Section 19, Facilities, of the CCAP Agreement. SCHOOL DISTRICT, shall extend access and use of the following SCHOOL DISTRICT facilities:

BUILDING NAME & ADDRESS	CLASSROOM	DAYS	HOURS
SAVA Sim 6207 Logan St Sacramento, CA 95824	TBD	Thursdays	FALL SEMESTER: 9am-noon
SAVA Elk Grove 3141 Dwight Rd Elk Grove, CA 95758	TBD	Thursdays	FALL SEMESTER: 9am-noon
SAVA Power Inn 5310 Power Inn Rd Sacramento, CA 95820 north	TBD	TBD	SPRING SEMESTER- TBD
SAVA North Natomas 1224 North Market Blvd Sacramento, CA 95834	TBD	TBD	SPRING SEMESTER- TBD

ALLAN HANCOCK JOINT COMMUNITY COLLEGE
DISTRICT

By: _____

Dr. Robert Curry

Associate Superintendent/Vice-President, Academic Affairs

Date: _____

ALLAN HANCOCK JOINT COMMUNITY COLLEGE
DISTRICT BOARD MEETINGS

Information Board Meeting Date: _____

Public Comment

and Approval Board Meeting Date: _____

Sacramento Academic & Vocational Academies

By: _____

Summer Ash

High School Director

Date: _____

GATEWAY COMMUNITY CHARTERS
BOARD MEETINGS

Information Board Meeting Date: _____

July TBD _____

Public Comment

and Approval Board Meeting Date: _____

August TBD _____

APPENDIX C

CCAP Agreement Courses Approved for 2025-2026

HIGH SCHOOL DISTRICT:

Gateway Community Charters

HIGH SCHOOL SITE / LOCATION:

Community Collaborative Charter School

PROJECTED NUMBER OF STUDENTS TO BE SERVED: 30

TOTAL PROJECTED FTES: 3.09

CCAP Pathway	College Degree or Certificate	High School Pathway	CCAP Course Offerings		Number of Sections, High School period(s) & Times		Instructor Name & Employer of Record (AHC or HS)		Projected Number of Students	Projected FTES
			FALL	SPRING	FALL	SPRING	FALL	SPRING		
College & Career Readiness	AA GE	College & Career Readiness	PROD 301	High school course	1 Periods & Times (TBD)	1 Periods & Times (TBD)	Shamina Quershi (HS)	Shamina Quershi (HS)	30	3.09

1. **REQUIRED:** Describe the criteria used to assess the ability of pupils to benefit from the course(s) offered:

In consultation with their SCHOOL DISTRICT counselors, students self-select a pathway based on their academic readiness and alignment of course content to students' educational and career goals. SCHOOL DISTRICT and COLLEGE faculty identified CCAP courses using the following criteria:

- a. Alignment with HIGH SCHOOL pathways and COLLEGE programs of study.
- b. Potential for course completion to accelerate students' time to completion of postsecondary degree or certificate.
- c. Potential to earn a Certificate of Training and be eligible to enter the workforce in their selected career technical pathway.
- d. Potential to work toward completion of an associate degree or an associate degree for transfer.

2. **MINIMUM QUALIFICATIONS FOR INSTRUCTION:** All instructors teaching CCAP Agreement Courses must meet the minimum qualifications for instruction in a California community college as set forth in Title 5 of the California Code of Regulations, sections 53410 and 58060 or as amended. The minimum qualifications for instruction are:

Course Name & Number	Minimum Qualifications For Instructors
PROD 301	<ul style="list-style-type: none"> • Master’s degree in counseling, rehabilitation counseling, clinical psychology, counseling psychology, guidance counseling, educational counseling, social work, career development, marriage and family therapy, or marriage, family, and child counseling • OR the equivalent <p>NOTE: A bachelor’s degree in one of the listed degrees and a license as a Marriage and Family Therapist (MFT) is an alternative qualification for this discipline</p> <ul style="list-style-type: none"> • OR master’s degree in education • OR any bachelor’s degree or higher and two years of professional experience in Office Technologies • OR any associate degree and six years of professional experience in Office Technologies. <p>NOTE: Professional experience is required when the application possesses a master’s degree. The professional experience required must be directly related to the teaching assignment.</p>

3. **BOOKS AND INSTRUCTIONAL MATERIALS:** The total cost of books and instructional materials for SCHOOL DISTRICT students participating in CCAP course as part of this CCAP Agreement will be borne by SCHOOL DISTRICT. The cost estimate is based on the current pricing and additions.

COURSE NAME & NUMBER	TEXTBOOK	COST	OTHER INSTRUCTIONAL MATERIALS	COST
PROD 301	Career Choices and Changes, M. Bingham, S. Stryker, 6 th Edition (2019)	\$59.95	My10yearPlan.com	\$35

4. **JOINT FACILITIES USE PROTOCOLS:** COLLEGE and SCHOOL DISTRICT shall adhere to the terms and protocols outlined in Section 19, Facilities, of the CCAP Agreement. SCHOOL DISTRICT, shall extend access and use of the following SCHOOL DISTRICT facilities:

BUILDING NAME & ADDRESS	CLASSROOM	DAYS	HOURS
Community Collaborative Charter School 5715 Skvarla Ave McClellan Park, CA 95652	TBD	Tuesdays	9 am -noon, FALL SEMESTER

ALLAN HANCOCK JOINT COMMUNITY COLLEGE
DISTRICT

COMMUNITY COLLABORATIVE CHARTER SCHOOL

By: _____
Dr. Robert Curry
Associate Superintendent/Vice-President, Academic Affairs

By: _____
Angee Phraxayavong-Briones
Principal

Date: _____

Date: _____

ALLAN HANCOCK JOINT COMMUNITY COLLEGE
DISTRICT BOARD MEETINGS

Information Board Meeting Date:

Public Comment
and Approval Board Meeting Date:

GATEWAY COMMUNITY CHARTERS
BOARD MEETINGS

Information Board Meeting Date:
_____ July TBD _____

Public Comment
and Approval Board Meeting Date:
_____ August TBD _____

APPENDIX D Registration Timeline 2025 - 2026

2025-2026 Week Ranges	Process	Timeline	Type
Week 1: July 1, 2025 - July 7, 2025			
Week 2: July 8, 2025 - July 14, 2025			
Week 3: July 15, 2025 - July 21, 2025			
Week 4: July 22, 2025 - July 28, 2025			
Week 5: July 29, 2025 - August 4, 2025	Ideal	CRNs available for DualEnroll & we see bulk of forms (Would like Aug 1 deadline for CRNs)	CCAP
Week 6: August 5, 2025 - August 11, 2025	Ideal	(NonCCAP) Late Add influx, Appeal Delays, Registration Processing Delays	
Week 6: August 5, 2025 - August 11, 2025	Ideal	Firm Deadline for NonCCAP Petitions (Fall 2025)	NonCCAP
Week 6: August 5, 2025 - August 11, 2025	Ideal	(NonCCAP) Bulk of Petitions come in around this time through first day of AHC classes	NonCCAP
Week 7: August 12, 2025 - August 18, 2025		Start of Fall Term for HS Partners (Average)	
Week 8: August 19, 2025 - August 25, 2025		Start of Fall Term for AHC	
Week 8: August 19, 2025 - August 25, 2025	Actual	(NonCCAP) We accepted petitions for up until the start of classes (extended)	NonCCAP
Week 8: August 19, 2025 - August 25, 2025		Winter app opens	
Week 9: August 26, 2025 - September 1, 2025	Actual	Influx of Fall Petitions Timeframe	Both
Week 9: August 26, 2025 - September 1, 2025	Actual	(NonCCAP) Late Add influx, Appeal Delays, Registration Processing Delays	NonCCAP
Week 10: September 2, 2025 - September 8, 2025	Actual	CRNs available in DualEnroll & we see beginning of bulk of forms	CCAP
Week 10: September 2, 2025 - September 8, 2025	Ideal	Spring app opens for CCAP students	CCAP
Week 11: September 9, 2025 - September 15, 2025			
Week 12: September 16, 2025 - September 22, 2025			
Week 14: September 30, 2025 - October 6, 2025	Ideal	CCAP CRNs available (Spring 2026)	CCAP
Week 14: September 30, 2025 - October 6, 2025	Ideal	CCAP Registration Begins (Spring 2026)	CCAP
Week 14: September 30, 2025 - October 6, 2025		Spring app opens	
Week 14: September 30, 2025 - October 6, 2025	Actual	Deadline for NonCCAP Petitions (Fall 2025 Term 2)	NonCCAP
Week 15: October 7, 2025 - October 13, 2025			
Week 16: October 14, 2025 - October 20, 2025	Actual	AHC accepting NonCCAP petitions (Winter/Spring 2026)	NonCCAP
Week 16: October 14, 2025 - October 20, 2025		Class Search opens	
Week 17: October 21, 2025 - October 27, 2025			
Week 18: October 28, 2025 - November 3, 2025	Ideal	Fall processing complete for CCAP	CCAP
Week 19: November 4, 2025 - November 10, 2025	Actual	CRN available for CCAP for spring	CCAP
Week 20: November 11, 2025 - November 17, 2025	Actual	NonCCAP Registration Begins (Winter/Spring 2026)	NonCCAP
Week 20: November 11, 2025 - November 17, 2025	Actual	CCAP Registration Begins (Early Spring 2026)	CCAP
Week 21: November 18, 2025 - November 24, 2025			
Week 22: November 25, 2025 - December 1, 2025			
Week 23: December 2, 2025 - December 8, 2025	Ideal	Influx of CN Spring Petitions Timeframe	NonCCAP

FALL

SPRING

APPENDIX D Registration Timeline 2025 - 2026

Week 23: December 2, 2025 - December 8, 2025	Ideal	Deadline for NonCCAP Petitions (Winter 2026)	CCAP
Week 24: December 9, 2025 - December 15, 2025	Ideal	Bulk of CCAP registrations submitted for Spring	CCAP
Week 25: December 16, 2025 - December 22, 2024	Actual	Processing completed for Fall CCAP	CCAP
Week 25: December 16, 2025 - December 22, 2025	Actual	Start of Winter Term for AHC	
Week 26: December 23, 2025 - December 29, 2025			
Week 27: December 30, 2025 - January 5, 2026			
Week 28: January 6, 2026 - January 12, 2026	Actual	Deadline for NonCCAP Petitions (Spring 2026)	
Week 29: January 13, 2026 - January 19, 2026	Actual	Start of Spring Term for HS Partners (Average)	Both
Week 29: January 13, 2026 - January 19, 2026	Actual	Influx of CN petitions	Both
Week 30: January 20, 2026 - January 26, 2026	Actual	Start of Spring Term for AHC	
Week 31: January 27, 2026 - February 2, 2026	Actual		
Week 32: February 3, 2026 - February 9, 2026	Actual	We see bulk of our CCAP forms being turned in	CCAP
Week 33: February 10, 2026 - February 16, 2026	Actual	We see bulk of our CCAP forms being turned in	CCAP
Week 34: February 17, 2026 - February 23, 2026		CCAP Sections Identify and Created - Alicia to meet with High Schools (summer/fall 2026)	
Week 35: February 24, 2026 - March 2, 2026			
Week 36: March 3, 2026 - March 9, 2026			
Week 37: March 10, 2026 - March 16, 2026			
Week 38: March 17, 2026 - March 23, 2026			
Week 39: March 24, 2026 - March 30, 2026		CCAP Sections CRNs Complete (summer/fall 2026)	
Week 40: March 31, 2026 - April 6, 2026			
Week 41: April 7, 2026 - April 13, 2026		AHC accepting NonCCAP petitions (summer/fall 2026)	
Week 41: April 7, 2026 - April 13, 2026	Actual	Summer/Fall Class Search Opens	
Week 42: April 14, 2026 - April 20, 2026			
Week 42: April 14, 2026 - April 20, 2026		Priority Reg	
Week 43: April 21, 2026 - April 27, 2026	Ideal	Spring processing complete for CCAP	CCAP
Week 44: April 28, 2026 - May 4, 2026			
Week 45: May 5, 2026 - May 11, 2026	Ideal	<i>NonCCAP Registration Begins (Summer/Fall 2026)</i>	
Week 46: May 12, 2026 - May 18, 2026	Actual	Deadline for NonCCAP Petitions (Spring Term 2 2026)	
Week 47: May 19, 2026 - May 25, 2026	Actual	Spring processing complete for CCAP	
Week 48: May 26, 2026 - June 1, 2026			
Week 49: June 2, 2026 - June 8, 2026	Ideal	Influx of Fall Petitions Timeframe	NonCCAP
Week 50: June 9, 2026 - June 15, 2026	Actual	Start of Summer Term for AHC	
Week 51: June 16, 2026 - June 22, 2026			
Week 52: June 23, 2026 - June 29, 2026			

SPRING

FALL

To: Board of Trustees	Date: July 15, 2025
From: Superintendent/President	
Subject: A Monthly Report on the Year-to-Date Financial Data for Various Funds	Item Number: 10.E.
Institutional Goal: Accreditation Standard III	Enclosures: Page 1 of 23

BACKGROUND

Attached are copies of financial statements for the following funds:

General Fund - Unrestricted
 General Fund - Restricted
 Child Development Fund
 PCPA Fund
 Capital Outlay Projects Fund
 General Obligation Bond Building Fund
 Dental Self-Insurance Fund
 Property and Liability Self-Insurance Fund
 Post-Employment Benefits Fund
 Other Post-Employment Benefits (OPEB) Trust Summary
 Associated Students Trust Fund
 Student Representation Fee Trust Fund
 Student Body Center Fee Trust Fund
 Student Financial Aid Trust Fund
 Scholarship and Loan Trust Fund
 District Trust Fund
 Student Clubs Agency Fund
 Foundation Agency Fund
 AHC Viticulture & Enology Foundation Agency Fund

The statements reflect year-to-date budgets and financial data.

Administrator Initiating Item: Dennis Curran	Final Disposition:
---	--------------------

GENERAL FUND UNRESTRICTED EXPENDITURE BUDGET

	May Budget	May Expenditures	Percentage Variance
Academic Salaries	2,986,825	2,966,906	99.33%
Classified Salaries	1,883,664	1,874,357	99.51%
Employee Benefits	1,624,653	1,589,977	97.87%
Supplies and Materials	205,565	181,417	88.25%
Other Operating Expenses	578,333	410,184	70.93%
Capital Outlay	179,711	124,278	69.15%
Other Outgo/Transfers	<u>630,772</u>	<u>555,401</u>	88.05%
	8,089,523	7,702,520	95.22%

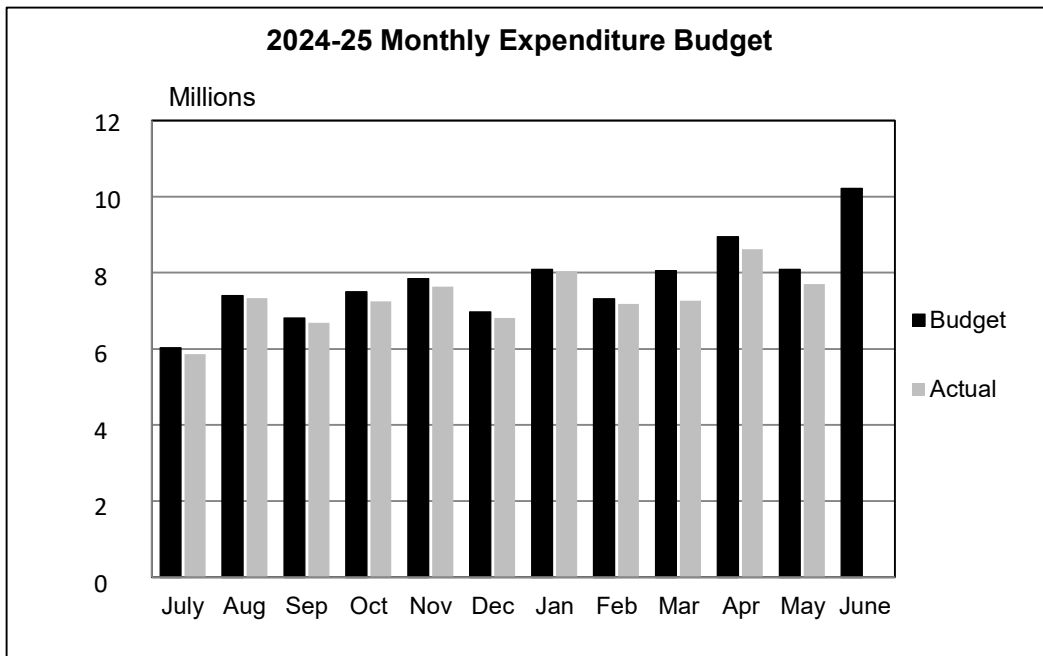

GENERAL FUND UNRESTRICTED EXPENDITURE BUDGET

Year to Date Expenditures

	July - May Budget	July - May Year to Date	Percentage Variance
Academic Salaries	30,351,198	30,348,734	99.99%
Classified Salaries	21,122,957	20,339,542	96.29%
Employee Benefits	16,937,308	16,528,323	97.59%
Supplies and Materials	1,905,225	1,530,402	80.33%
Other Operating Expenses	8,308,888	7,435,337	89.49%
Capital Outlay	751,637	654,727	87.11%
Other Outgo/Transfers	<u>3,684,126</u>	<u>3,549,883</u>	96.36%
	83,061,339	80,386,948	96.78%

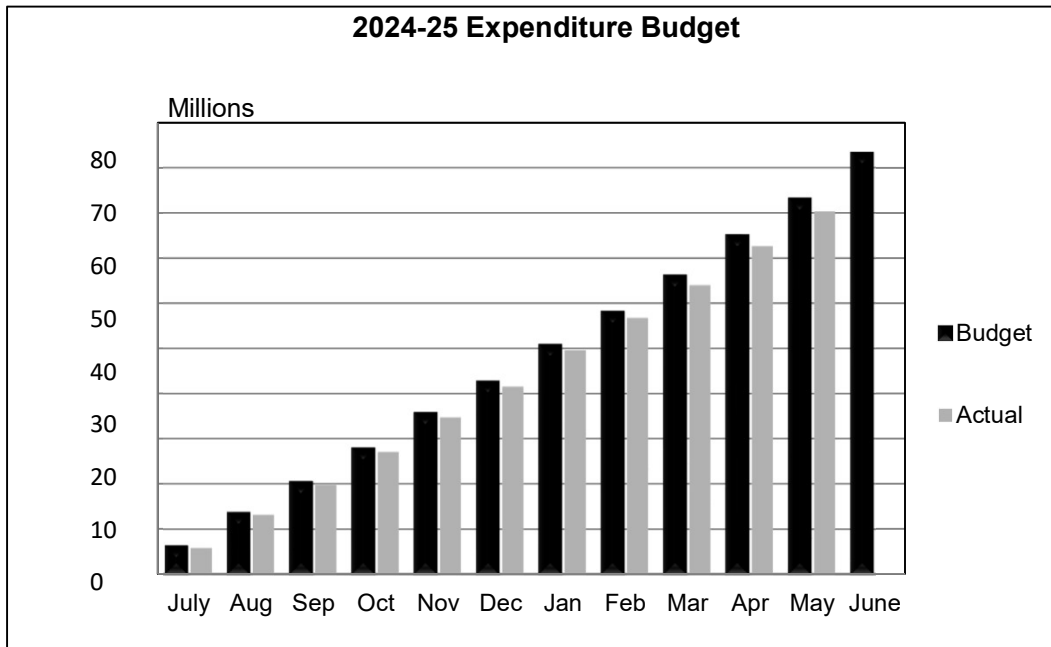

Allan Hancock College
General Fund

Income Statement by Fund
For Period Ending 05/31/2025

	<u>Unrestricted Budget</u>	<u>Unrestricted Actual</u>	<u>% Budget</u>	<u>Restricted Budget</u>	<u>Restricted Actual</u>	<u>% Budget</u>
REVENUES						
Federal Revenues	\$ 5,200	\$ 47,523	913.90%	\$ 5,564,216	\$ 1,507,826	27.10%
State Revenues	59,442,965	42,822,932	72.04%	40,143,285	35,643,368	88.79%
Local Revenues	27,136,807	27,983,752	103.12%	2,092,874	2,053,404	98.11%
Total REVENUES	<u>86,584,972</u>	<u>70,854,207</u>	<u>81.83%</u>	<u>47,800,375</u>	<u>39,204,597</u>	<u>82.02%</u>
EXPENDITURES						
Academic Salaries	31,493,437	30,348,734	96.37%	5,805,339	3,473,475	59.83%
Classified Salaries	23,309,531	20,339,542	87.26%	9,495,447	6,485,917	68.31%
Employee Benefits	20,581,643	16,528,323	80.31%	4,595,482	2,815,004	61.26%
Supplies and Materials	2,110,842	1,530,402	72.50%	4,090,645	2,271,904	55.54%
Other Operating Exp. and Services	9,705,746	7,435,337	76.61%	7,631,702	3,914,033	51.29%
Capital Outlay	920,305	654,727	71.14%	3,844,416	1,792,923	46.64%
Total EXPENDITURES	<u>88,121,503</u>	<u>76,837,065</u>	<u>87.19%</u>	<u>35,463,031</u>	<u>20,753,256</u>	<u>58.52%</u>
Excess of Revenues Over/ (Under) Expenditures	(1,536,531)	(5,982,858)		12,337,344	18,451,342	
OTHER FINANCING SOURCES (USES)						
Other Financing Sources	0	76,659	0.00%	87,205	83,900	96.21%
Total OTHER FINANCING SOURCES (USES)	<u>0</u>	<u>76,659</u>	<u>0.00%</u>	<u>87,205</u>	<u>83,900</u>	<u>96.21%</u>
OPERATING TRANSFERS OUT						
Other Outgo	5,161,877	3,549,883	68.77%	9,739,036	4,104,175	42.14%
Total OPERATING TRANSFERS OUT	<u>5,161,877</u>	<u>3,549,883</u>	<u>68.77%</u>	<u>9,739,036</u>	<u>4,104,175</u>	<u>42.14%</u>
Excess of Revenues and Other Financing Sources Over/(Under)	(6,698,408)	(9,456,082)		2,685,514	14,431,067	
FUND BALANCE						
Fund Balance, July 1st	<u>32,078,920</u>	<u>32,078,920</u>		<u>11,060,798</u>	<u>11,060,798</u>	
Current Balance	<u>\$ 25,380,513</u>	<u>\$ 22,622,838</u>		<u>\$ 13,746,312</u>	<u>\$ 25,491,865</u>	

Allan Hancock College
Child Development Fund

Income Statement by Fund
For Period Ending 05/31/2025

	<u>Budget</u>	<u>Actual</u>	<u>% Budget</u>
REVENUES			
Federal Revenues	\$ 391,156	\$ 312,674	79.94%
State Revenues	1,440,987	1,314,733	91.24%
Local Revenues	563,163	322,869	57.33%
Total REVENUES	<u>2,395,306</u>	<u>1,950,275</u>	<u>81.42%</u>
EXPENDITURES			
Academic Salaries	104,459	148,536	142.20%
Classified Salaries	1,295,304	793,776	61.28%
Employee Benefits	230,975	186,041	80.55%
Supplies and Materials	314,479	103,195	32.81%
Other Operating Exp. and Services	46,303	19,375	41.84%
Capital Outlay	435,242	283,273	65.08%
Total EXPENDITURES	<u>2,426,761</u>	<u>1,534,197</u>	<u>63.22%</u>
Excess of Revenues Over/ (Under) Expenditures	(31,455)	416,078	
OTHER FINANCING SOURCES (USES)			
Other Financing Sources	30,000	30,000	100.00%
Total OTHER FINANCING SOURCES (USES)	<u>30,000</u>	<u>30,000</u>	<u>100.00%</u>
OPERATING TRANSFERS OUT			
Other Outgo	1,405	0	0.00%
Total OPERATING TRANSFERS OUT	<u>1,405</u>	<u>0</u>	<u>0.00%</u>
Excess of Revenues and Other Financing Sources Over/(Under) Expenditures and Other Uses	(2,860)	446,078	
FUND BALANCE			
Fund balance, July 1	580,666	580,666	
Current Balance	<u>\$ 577,806</u>	<u>\$ 1,026,744</u>	

Allan Hancock College
PCPA Fund

Income Statement by Fund
For Period Ending
05/31/2025

	<u>Budget</u>	<u>Actual</u>	<u>% Budget</u>
REVENUES			
Local Revenues	\$ 2,833,920	\$ 3,026,811	106.81%
Total REVENUES	<u>2,833,920</u>	<u>3,026,811</u>	<u>106.81%</u>
EXPENDITURES			
Classified Salaries	3,568,102	2,936,281	82.29%
Employee Benefits	823,209	715,646	86.93%
Supplies and Materials	415,388	236,388	56.91%
Other Operating Exp. and Services	695,537	792,796	113.98%
Capital Outlay	31,178	25,572	82.02%
Total EXPENDITURES	<u>5,533,414</u>	<u>4,706,683</u>	<u>85.06%</u>
Excess of Revenues Over/ (Under) Expenditures	(2,699,494)	(1,679,872)	
OTHER FINANCING SOURCES (USES)			
Other Financing Sources	3,009,320	2,507,766	83.33%
Total OTHER FINANCING SOURCES (USES)	<u>3,009,320</u>	<u>2,507,766</u>	<u>83.33%</u>
OPERATING TRANSFERS OUT			
Other Outgo	1,125,433	1,039,859	92.40%
Total OPERATING TRANSFERS OUT	<u>1,125,433</u>	<u>1,039,859</u>	<u>92.40%</u>
Excess of Revenues and Other Financing Sources Over/(Under) Expenditures and Other Uses	(815,607)	(211,965)	
FUND BALANCE			
Fund balance, July 1	4,029,232	4,029,232	
Current Balance	<u>\$ 3,213,626</u>	<u>\$ 3,817,267</u>	

Allan Hancock College
Capital Outlay Project Fund

Income Statement by Fund
For Period Ending 05/31/2025

	<u>Budget</u>	<u>Actual</u>	<u>% Budget</u>
REVENUES			
State Revenues	\$ 0	\$ 0	0.00%
Local Revenues	25,000	424,149	1,696.60%
Total REVENUES	<u>25,000</u>	<u>424,149</u>	<u>1,696.60%</u>
EXPENDITURES			
Supplies and Materials	49,467	15,872	32.09%
Other Operating Exp. and Services	122,323	49,779	40.69%
Capital Outlay	6,712,602	3,147,194	46.88%
Total EXPENDITURES	<u>6,884,392</u>	<u>3,212,845</u>	<u>46.67%</u>
Excess of Revenues Over/ (Under) Expenditures	(6,859,392)	(2,788,696)	
OTHER FINANCING SOURCES (USES)			
Other Financing Sources	2,737,960	398,680	14.56%
Total OTHER FINANCING SOURCES (USES)	<u>2,737,960</u>	<u>398,680</u>	<u>14.56%</u>
OPERATING TRANSFERS OUT			
Other Outgo	0	0	0.00%
Total OPERATING TRANSFERS OUT	<u>0</u>	<u>0</u>	<u>0.00%</u>
Excess of Revenues and Other Financing Sources Over/(Under) Expenditures and Other Uses	(4,121,432)	(2,390,016)	
FUND BALANCE			
Fund balance, July 1	<u>14,076,905</u>	<u>14,076,905</u>	
Current Balance	<u>\$ 9,955,472</u>	<u>\$ 11,686,889</u>	

Allan Hancock College
General Obligation Bond Fund

Income Statement by Fund
For Period Ending 05/31/2025

	<u>Budget</u>	<u>Actual</u>	<u>% Budget</u>
REVENUES			
Local Revenues	\$ 75,000	\$ 133,684	178.25%
Total REVENUES	<u>75,000</u>	<u>133,684</u>	<u>178.25%</u>
EXPENDITURES			
Supplies and Materials	0	0	0.00%
Other Operating Exp. and Services	72,211	61,556	85.25%
Capital Outlay	4,139,494	874,060	21.12%
Total EXPENDITURES	<u>4,211,704</u>	<u>935,616</u>	<u>22.21%</u>
Excess of Revenues Over/ (Under) Expenditures	(4,136,704)	(801,932)	
OTHER FINANCING SOURCES (USES)			
Other Financing Sources	1,915,330	1,915,330	100.00%
Total OTHER FINANCING SOURCES (USES)	<u>1,915,330</u>	<u>1,915,330</u>	<u>100.00%</u>
OPERATING TRANSFERS OUT			
Other Outgo	1,915,330	1,915,330	100.00%
Total OPERATING TRANSFERS OUT	<u>1,915,330</u>	<u>1,915,330</u>	<u>100.00%</u>
Excess of Revenues and Other Financing Sources Over/(Under) Expenditures and Other Uses	(4,136,704)	(801,932)	
FUND BALANCE			
Fund balance, July 1	6,309,167	6,309,167	
Current Balance	<u>\$ 2,172,463</u>	<u>\$ 5,507,236</u>	

Allan Hancock College
Dental Self Insurance Fund

Income Statement by Fund
For Period Ending 05/31/2025

	<u>Budget</u>	<u>Actual</u>	<u>% Budget</u>
REVENUES			
Local Revenues	\$ 714,425	\$ 782,904	109.59%
Total REVENUES	<u>714,425</u>	<u>782,904</u>	<u>109.59%</u>
EXPENDITURES			
Other Operating Exp. and Services	<u>769,917</u>	<u>703,990</u>	91.44%
Total EXPENDITURES	<u>769,917</u>	<u>703,990</u>	91.44%
Excess of Revenues Over/ (Under) Expenditures	(55,492)	78,914	
FUND BALANCE			
Fund balance, July 1	<u>979,127</u>	<u>979,127</u>	
Current Balance	<u>\$ 923,635</u>	<u>\$ 1,058,041</u>	

Allan Hancock College
Self Ins - Property & Liab. Fund

Income Statement by Fund
For Period Ending 05/31/2025

	<u>Budget</u>	<u>Actual</u>	<u>% Budget</u>
REVENUES			
Local Revenues	\$ 23,511	\$ 77,021	327.59%
Total REVENUES	<u>23,511</u>	<u>77,021</u>	<u>327.59%</u>
EXPENDITURES			
Supplies and Materials	0	0	0.00%
Other Operating Exp. and Services	88,937	88,937	100.00%
Capital Outlay	15,875	14,569	91.77%
Total EXPENDITURES	<u>104,813</u>	<u>103,507</u>	<u>98.75%</u>
Excess of Revenues Over/ (Under) Expenditures	(81,301)	(26,486)	
FUND BALANCE			
Fund balance, July 1	<u>855,019</u>	<u>855,019</u>	
Current Balance	<u>\$ 773,718</u>	<u>\$ 828,533</u>	

Allan Hancock College
Post Employment Benefits Fund

Income Statement by Fund
For Period Ending 05/31/2025

	<u>Budget</u>	<u>Actual</u>	<u>% Budget</u>
REVENUES			
Local Revenues	\$ 4,000	\$ 23,649	591.23%
Total REVENUES	<u>4,000</u>	<u>23,649</u>	<u>591.23%</u>
EXPENDITURES			
Other Operating Exp. and Services	31,300	3,300	10.54%
Total EXPENDITURES	<u>31,300</u>	<u>3,300</u>	<u>10.54%</u>
Excess of Revenues Over/ (Under) Expenditures	(27,300)	20,349	
FUND BALANCE			
Fund balance, July 1	<u>1,018,975</u>	<u>1,018,975</u>	
Current Balance	<u>\$ 991,675</u>	<u>\$ 1,039,324</u>	

02490204
 15- -01-B -61 -156-04
 0101 -11-03818-04



RHBPT-HANCOCK-DELEGATED DISCRETION
 ACCOUNT 6746018043

Period from May 1, 2025 to May 31, 2025

MARKET AND COST RECONCILIATION

	05/31/2025 MARKET	05/31/2025 BOOK VALUE
Beginning Market And Cost	10,749,648.54	10,359,607.22
Investment Activity		
Interest	48.43	48.43
Dividends	20,726.60	20,726.60
Realized Gain/Loss	61,912.96	61,912.96
Change In Unrealized Gain/Loss	138,145.85	.00
Net Accrued Income (Current-Prior)	1.34	1.34
Total Investment Activity	220,835.18	82,689.33
Net Change In Market And Cost	220,835.18	82,689.33
Ending Market And Cost	10,970,483.72	10,442,296.55

02490204
 15- -01-B -61 -156-04
 0101 -11-03818-04



RHBPT-HANCOCK-DELEGATED DISCRETION
 ACCOUNT 6746018043

Period from May 1, 2025 to May 31, 2025

ASSET SUMMARY

ASSETS	05/31/2025 MARKET	05/31/2025 BOOK VALUE	% OF MARKET
Cash And Equivalents	14,029.15	14,029.15	0.13
Mutual Funds-Equity	4,267,484.17	3,523,793.35	38.90
Mutual Funds-Fixed Income	5,923,133.76	6,235,833.51	53.99
Mutual Funds-Balanced	765,758.30	668,562.20	6.98
Total Assets	10,970,405.38	10,442,218.21	100.00
Accrued Income	78.34	78.34	0.00
Grand Total	10,970,483.72	10,442,296.55	100.00

Estimated Annual Income **378,884.02**

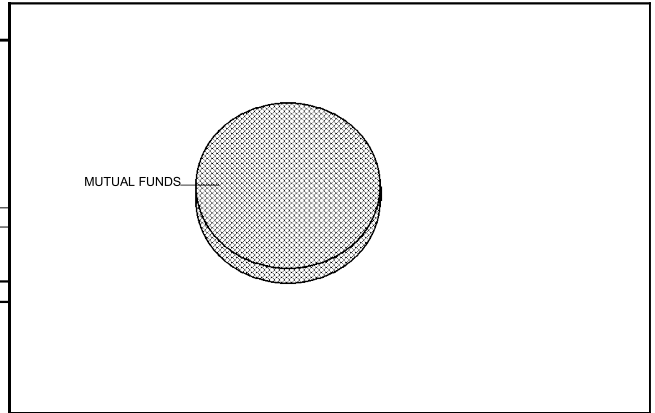

ASSET SUMMARY MESSAGES

Estimated Annual Income is an estimate provided for informational purposes only and should not be relied on for making investment, trading, or tax decisions. The estimates may not represent the actual value earned by your investments and they provide no guarantee of what your investments may earn in the future.

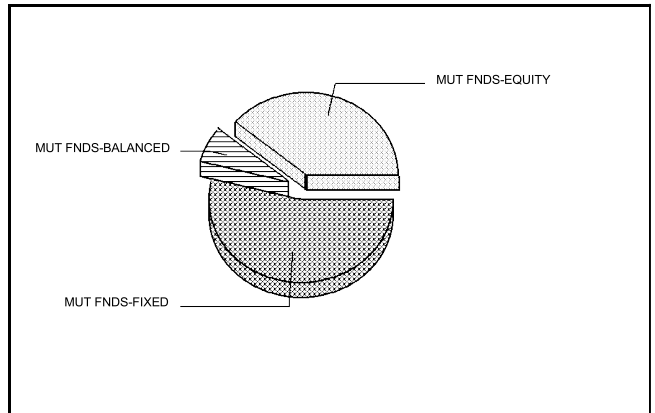

Allan Hancock College
Associated Students Trust Fund

Income Statement by Fund
For Period Ending 05/31/2025

	<u>Budget</u>	<u>Actual</u>	<u>% Budget</u>
REVENUES			
Local Revenues	\$ 93,061	\$ 145,890	156.77%
Total REVENUES	<u>93,061</u>	<u>145,890</u>	<u>156.77%</u>
EXPENDITURES			
Supplies and Materials	342,763	279,683	81.60%
Other Operating Exp. and Services	121,548	102,225	84.10%
Total EXPENDITURES	<u>464,311</u>	<u>381,909</u>	<u>82.25%</u>
Excess of Revenues Over/ (Under) Expenditures	(371,250)	(236,019)	
OTHER FINANCING SOURCES (USES)			
Other Financing Sources	428,270	437,270	102.10%
Total OTHER FINANCING SOURCES (USES)	<u>428,270</u>	<u>437,270</u>	<u>102.10%</u>
OPERATING TRANSFERS OUT			
Other Outgo	193,805	201,245	103.84%
Total OPERATING TRANSFERS OUT	<u>193,805</u>	<u>201,245</u>	<u>103.84%</u>
Excess of Revenues and Other Financing Sources Over/(Under) Expenditures and Other Uses	(136,784)	7	
FUND BALANCE			
Fund balance, July 1	<u>303,998</u>	<u>303,998</u>	
Current Balance	<u>\$ 167,214</u>	<u>\$ 304,005</u>	

Allan Hancock College
Student Representation Fee Trst Fnd

Income Statement by Fund
For Period Ending 05/31/2025

	<u>Budget</u>	<u>Actual</u>	<u>% Budget</u>
REVENUES			
Local Revenues	\$ 41,160	\$ 60,303	146.51%
Total REVENUES	<u>41,160</u>	<u>60,303</u>	<u>146.51%</u>
EXPENDITURES			
Other Operating Exp. and Services	31,202	27,999	89.74%
Total EXPENDITURES	<u>31,202</u>	<u>27,999</u>	<u>89.74%</u>
Excess of Revenues Over/ (Under) Expenditures	9,958	32,304	
OPERATING TRANSFERS OUT			
Other Outgo	0	0	0.00%
Total OPERATING TRANSFERS OUT	<u>0</u>	<u>0</u>	<u>0.00%</u>
Excess of Revenues and Other Financing Sources Over/(Under) Expenditures and Other Uses	9,958	32,304	
FUND BALANCE			
Fund balance, July 1	<u>21,814</u>	<u>21,814</u>	
Current Balance	<u>\$ 31,772</u>	<u>\$ 54,118</u>	

Allan Hancock College
Student Body Center Fee Trust Fund

Income Statement by Fund
For Period Ending 05/31/2025

	<u>Budget</u>	<u>Actual</u>	<u>% Budget</u>
REVENUES			
Local Revenues	\$ 25,300	\$ 43,328	171.26%
Total REVENUES	<u>25,300</u>	<u>43,328</u>	<u>171.26%</u>
EXPENDITURES			
Supplies and Materials	4,616	0	0.00%
Other Operating Exp. and Services	65	0	0.00%
Capital Outlay	<u>0</u>	<u>0</u>	<u>0.00%</u>
Total EXPENDITURES	<u>4,680</u>	<u>0</u>	<u>0.00%</u>
Excess of Revenues Over/ (Under) Expenditures	20,620	43,328	
FUND BALANCE			
Fund balance, July 1	<u>95,030</u>	<u>95,030</u>	
Current Balance	<u>\$ 115,649</u>	<u>\$ 138,358</u>	

Allan Hancock College
Student Financial Aid Trust Fund

Income Statement by Fund
For Period Ending 05/31/2025

	<u>Budget</u>	<u>Actual</u>	<u>% Budget</u>
REVENUES			
Federal Revenues	\$ 11,178,459	\$ 17,326,526	155.00%
State Revenues	3,965,246	4,402,071	111.02%
Local Revenues	0	10	0.00%
Total REVENUES	<u>15,143,705</u>	<u>21,728,607</u>	<u>143.48%</u>
OTHER FINANCING SOURCES (USES)			
Other Financing Sources	634,762	978,635	154.17%
Total OTHER FINANCING SOURCES (USES)	<u>634,762</u>	<u>978,635</u>	<u>154.17%</u>
OPERATING TRANSFERS OUT			
Other Outgo	15,778,467	22,540,749	142.86%
Total OPERATING TRANSFERS OUT	<u>15,778,467</u>	<u>22,540,749</u>	<u>142.86%</u>
Excess of Revenues and Other Financing Sources Over/(Under) Expenditures and Other Uses	0	166,493	
FUND BALANCE			
Fund balance, July 1	<u>21,809</u>	<u>21,809</u>	
Current Balance	<u>\$ 21,809</u>	<u>\$ 188,302</u>	

Allan Hancock College
Scholarship and Loan Trust Fund

Income Statement by Fund
For Period Ending 05/31/2025

	<u>Budget</u>	<u>Actual</u>	<u>% Budget</u>
REVENUES			
Local Revenues	\$ 1,000	\$ 0	0.00%
Total REVENUES	<u>1,000</u>	<u>0</u>	<u>0.00%</u>
OPERATING TRANSFERS OUT			
Other Outgo	1,000	0	0.00%
Total OPERATING TRANSFERS OUT	<u>1,000</u>	<u>0</u>	<u>0.00%</u>
Excess of Revenues and Other Financing Sources Over/(Under) Expenditures and Other Uses	0	0	
FUND BALANCE			
Fund balance, July 1	<u>8,708</u>	<u>8,708</u>	
Current Balance	<u>\$ 8,708</u>	<u>\$ 8,708</u>	

Allan Hancock College
District Trust Fund

Income Statement by Fund
For Period Ending 05/31/2025

	<u>Budget</u>	<u>Actual</u>	<u>% Budget</u>
REVENUES			
Local Revenues	\$ 208,849	\$ 607,706	290.98%
Total REVENUES	<u>208,849</u>	<u>607,706</u>	<u>290.98%</u>
EXPENDITURES			
Academic Salaries	17,445	9,750	55.89%
Classified Salaries	1,000	0	0.00%
Employee Benefits	0	0	0.00%
Supplies and Materials	116,835	90,641	77.58%
Other Operating Exp. and Services	51,081	31,143	60.97%
Capital Outlay	0	0	0.00%
Total EXPENDITURES	<u>186,361</u>	<u>131,534</u>	<u>70.58%</u>
Excess of Revenues Over/ (Under) Expenditures	22,488	476,172	
OPERATING TRANSFERS OUT			
Other Outgo	27,241	14,444	53.02%
Total OPERATING TRANSFERS OUT	<u>27,241</u>	<u>14,444</u>	<u>53.02%</u>
Excess of Revenues and Other Financing Sources Over/(Under) Expenditures and Other Uses	(4,754)	461,728	
FUND BALANCE			
Fund balance, July 1	<u>5,789,497</u>	<u>5,789,497</u>	
Current Balance	<u>\$ 5,784,743</u>	<u>\$ 6,251,224</u>	

Allan Hancock Joint Community College District
 Plan Activity Report - Pension
 As of May 31, 2025



Month		Balance at the 1st of the Month	Contributions	Earnings	Expenses	Distributions	Transfers	Balance at the End of Month
March 2025	\$	5,072,407.66	\$0.00	(\$71,944.03)	(\$1,359.15)	\$0.00	\$0.00	\$ 4,999,104.48
April 2025	\$	4,999,104.48	\$0.00	\$22,139.41	(\$1,342.11)	\$0.00	\$0.00	\$ 5,019,901.78
May 2025	\$	5,019,901.78	\$0.00	\$97,705.20	(\$1,346.85)	\$0.00	\$0.00	\$ 5,116,260.13

Allan Hancock College
Student Clubs Agency Fund

Income Statement by Fund
For Period Ending 05/31/2025

	<u>Budget</u>	<u>Actual</u>	<u>% Budget</u>
REVENUES			
Local Revenues	\$ 37,245	\$ 52,865	141.94%
Total REVENUES	<u>37,245</u>	<u>52,865</u>	<u>141.94%</u>
EXPENDITURES			
Supplies and Materials	25,426	14,046	55.24%
Other Operating Exp. and Services	16,084	8,552	53.17%
Total EXPENDITURES	<u>41,510</u>	<u>22,599</u>	<u>54.44%</u>
Excess of Revenues Over/ (Under) Expenditures	(4,265)	30,267	
OPERATING TRANSFERS OUT			
Other Outgo	21,530	19,530	90.71%
Total OPERATING TRANSFERS OUT	<u>21,530</u>	<u>19,530</u>	<u>90.71%</u>
Excess of Revenues and Other Financing Sources Over/(Under) Expenditures and Other Uses	(25,795)	10,737	
FUND BALANCE			
Fund balance, July 1	<u>64,195</u>	<u>64,195</u>	
Current Balance	<u>\$ 38,400</u>	<u>\$ 74,932</u>	

360
ALLAN HANCOCK COLLEGE FOUNDATION
STATEMENT OF OPERATIONS
FOR THE PERIOD ENDING 05/31/2025

	Cash Admin	General Operations	Restricted	Scholar- ships	Endowment Principal	Endowment Rev/Exp	Total
REVENUES:							
Contributions, Gifts, Grants & Endwmnts	0	209,528	517,781	477,037	213,011	0	1,417,357
Non Cash Contribution	0	0	9,432	0	0	0	9,432
Interest and Investment Income	0	38,408	411	0	0	706,767	745,586
Realized Gain/Loss on Invest	0	7,624	0	0	0	570,324	577,948
Unrealized Gain/Loss on Invest	0	14,144	0	0	0	515,338	529,482
Other Local Revenues	0	1,249	25,778	7,845	0	0	34,872
Total Revenues	0	270,953	553,402	484,883	213,011	1,792,429	3,314,678
EXPENSES:							
Non Bargaining Unit	0	274,344	0	0	0	0	274,344
Benefits	0	62,202	0	0	0	0	62,202
Instructional Printing	0	0	1,517	0	0	0	1,517
Public Relations/Recognitions	0	2,287	13	0	0	0	2,301
Office/Operational Supplies	0	4,482	39,068	0	0	0	43,550
Non Instr Printing	0	6,676	2,148	0	0	0	8,824
Food - Business Meetings/Events	0	17,598	80,748	0	0	0	98,346
In-Kind Food Supplies	0	0	185	0	0	0	185
Indep Contractor (Individuals)	0	21,891	42,688	0	0	0	64,579
Service Contracts (Businesses)	0	23,262	77,737	0	0	0	100,998
In-Kind Service Contracts (Busnss)	0	0	3,302	0	0	0	3,302
Travel - All Travel Costs	0	10,611	4,154	0	0	0	14,765
In-Kind Travel Expense	0	0	946	0	0	0	946
On-Site-Prof. Develop/Webinars	0	1,183	200	0	0	0	1,383
District Community Activities	0	1,250	0	0	0	0	1,250
Foundation Community Activities	0	25,203	5,000	0	0	0	30,203
Dues & Memberships	0	5,677	294	0	0	0	5,971
Non-Tech Licenses, Permits, Fees	0	922	2,161	0	0	0	3,083
Software License/Subscription Agrmt	0	29,767	5,320	0	0	0	35,087
Insurance	0	0	190	0	0	0	190
Laundry/Dry Cleaning	0	35	0	0	0	0	35
Equipment Rental	0	0	2,524	0	0	0	2,524
District/College Support	0	25,084	201,066	0	0	0	226,150
Postage/Express Services	0	2,757	566	0	0	0	3,323
Advertising/Sponsorships	0	3,700	39	0	0	0	3,739
In-Kind Advertising	0	0	5,000	0	0	0	5,000
Bank Service Charges	0	1,168	377	0	0	0	1,545
Merchant Fees	0	0	598	0	0	0	598
Investment Brokerage Fees	0	2,964	0	0	0	152,492	155,456
Cash Over and Short	0	0	0	0	0	0	0
PCPA Support	0	0	14,511	78,680	0	0	93,191
Equipment	0	631	28,323	0	0	0	28,954
Student Assistance	0	0	9,559	0	0	0	9,559
Scholarships	0	2,461	141,497	565,585	0	0	709,542
Total Expenditures	0	526,152	669,732	644,265	0	152,492	1,992,641
Net Income (Loss)	0	(255,200)	(116,330)	(159,382)	213,011	1,639,937	1,322,037
OTHER FINANCING SOURCES/OUTGO:							
Intrafund Transfer-In	0	130,294	226,029	282,174	143,546	0	782,044
Intrafund Transfers-Out	0	19	154,583	2,000	0	625,442	782,044
Other Transfer-In	0	330,337	0	0	0	0	330,337
Net Transfers	0	460,612	71,447	280,174	143,546	(625,442)	330,337
Net Inc/Dec in Fund Bal	0	205,412	(44,883)	120,792	356,557	1,014,495	1,652,374
FUND BALANCE:							
Fund Equity, July 1	0	735,205	1,662,110	836,488	17,531,279	4,617,775	25,382,858
Current Balance	0	940,617	1,617,227	957,280	17,887,836	5,632,270	27,035,232

AHC Viticulture & Enology Foundation
Statement of Operations
For The Period Ending 05/31/2025

	Budget	Actual	% Budget
Revenue			
Contributions, Gifts, Grants & Endwmnts	3,241	1,838	56.73%
Non Cash Contribution	22,018	21,955	99.71%
Single Tickets	8,930	7,205	80.68%
Other Local Revenues	0	100	0.00%
Net Revenue	<u>34,188</u>	<u>31,098</u>	<u>90.96%</u>
Wine Operations			
Shipping Fee Revenue	1,300	806	62.03%
Sales and Commission	90,000	113,527	126.14%
Sales Discounts	<u>(31,500)</u>	<u>(43,219)</u>	<u>137.20%</u>
Net Sales	59,800	71,115	118.92%
Cost of Goods Sold	<u>(45,000)</u>	<u>(44,532)</u>	<u>98.96%</u>
Gross Profit	14,800	26,583	179.61%
Total REVENUES	48,988	57,681	117.74%
Expenditures			
Public Relations/Recognitions	600	0	0.00%
Office/Operational Supplies	20,918	16,590	79.31%
In Kind Supply Expense	2,145	1,990	92.76%
Inventory Allocation Expense	(71,131)	(50,608)	71.15%
Non Instr Printing	2,853	2,844	99.70%
Food - Business Meetings/Events	1,361	345	25.35%
In-Kind Food Supplies	1,093	0	0.00%
Indep Contractor (Individuals)	1,811	0	0.00%
Service Contracts (Businesses)	46,589	38,684	83.03%
Travel - All Travel Costs	5,536	1,795	32.42%
Non-Tech Licenses, Permits, Fees	824	774	93.93%
In Kind-Software/Technlgy Licenses	19,980	18,315	91.67%
Insurance	300	281	93.67%
Facility Leases	100	100	100.00%
Land Lease	400	400	100.00%
Repairs (Labor-Diagnostic)	3,731	3,652	97.89%
Technology Hosting Services	85	46	54.32%
Legal Fees	390	0	0.00%
In Kind-Legal Fees	325	0	0.00%
Excise Tax	35	19	53.09%
Sales Tax Expense	400	168	42.02%
Postage/Express Services	1,600	1,213	75.80%
Advertising/Sponsorships	2,621	1,527	58.26%
Bank Service Charges	25	0	0.00%
Merchant Fees	2,715	2,424	89.31%
Gain/Loss-Disposal of Assets	3,763	3,763	100.00%
Bad Debt Expense	2	2	100.00%
Cash Over and Short	5	5	92.80%
Equipment	2,204	2,204	100.00%
Equipment-In Kind	1,870	1,650	88.23%
Restricted Reserve-Other	8,025	0	0.00%
Total EXPENDITURES	<u>61,175</u>	<u>48,184</u>	<u>78.76%</u>
Fund Balance			
Net Income (Loss)	(12,187)	9,497	(77.93%)
Fund Balance, July 1	165,319	165,319	165,319
Current Balance	<u>\$153,132</u>	<u>\$174,816</u>	<u>114.16%</u>

JULY 2025

ALLAN HANCOCK COLLEGE

Sun	Mon	Tue	Wed	Thu	Fri	Sat
		1 <i>Waitress</i> through July 6 Solvang Festival Theater	2	3	4 Independence Day Holiday College Closed	5 8:00 a.m. <i>Community Food Share</i> 1st & 3rd Saturday
6	7	8	9	10	11 <i>Holmes and Watson</i> through July 26 Solvang Festival Theater	12
13	14	15 10:00 a.m. Board of Trustees Meeting LVC	16 Summer 6-wk classes end & finals through July 17	17 <i>Something Rotten</i> through July 26 Marian Theatre	18	19
20	21	22	23	24	25	26
27	28	29	30 Summer 8-wk classes end & finals through July 31	31		

AUGUST 2025

ALLAN HANCOCK COLLEGE

Sun	Mon	Tue	Wed	Thu	Fri	Sat
					1 <i>Something Rotten</i> through August 23 Solvang Festival Theatre	2 8:00 a.m. <i>Community Food Share</i> 1st and 3rd Saturday
3	4	5 4:00 p.m. Hancock Hello Lompoc Valley Center	6	7	8	9
10	11	12 4:00 p.m. Hancock Hello Santa Maria campus	13	14 All Staff Day <i>Songs For Nobodies</i> through August 23 Marian Theatre	15 Professional Development Day	16
17	18 Fall & Term 1 Classes Begin	19 6:00 p.m. Board of Trustees Meeting	20	21 <i>The Agitators</i> through August 25 Marian Theatre	22 4:00 p.m. Men's Soccer vs. Clovis Community College	23
24	25	26 2:00 p.m.-Men's 4:00 p.m.-Women's Soccer vs. Santa Monica College	27 10:00 a.m. Bulldog Bow-WOW Mechanics Bank Student Center Santa Maria campus	28 <i>Songs For Nobodies</i> through Sept. 7 Solvang Festival Theater	29 4:00 p.m. Men's Soccer vs. College of the Sequoias	30 2:00 p.m. Football vs. Orange Coast College
31						